

Parts Catalog

Mazda RX-7
U.S.A.
('81-'83)

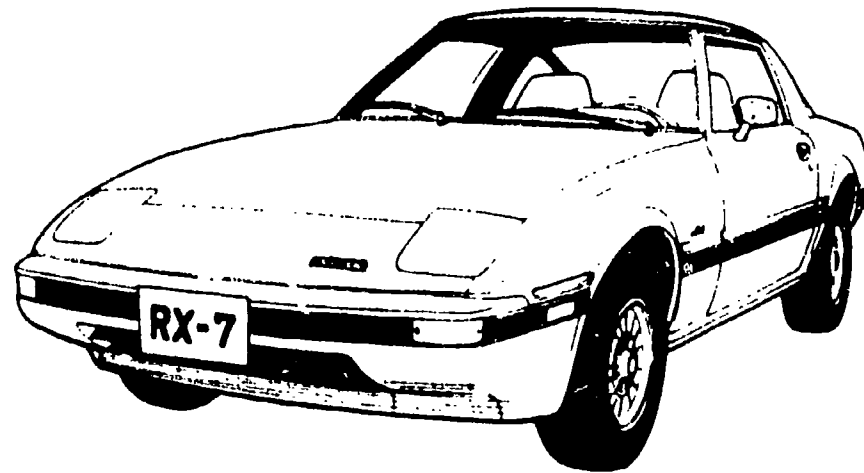







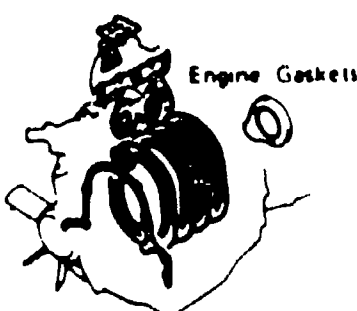
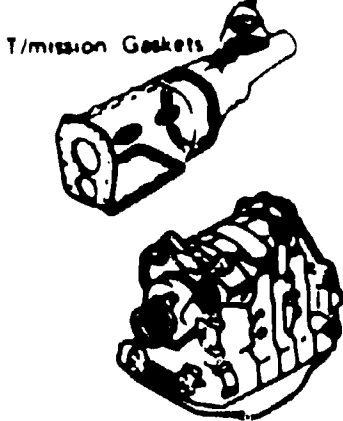
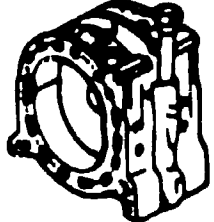

(FB331-500001 ~) (Mazda Rotary Engine Licensed by NSU-WANKEL)

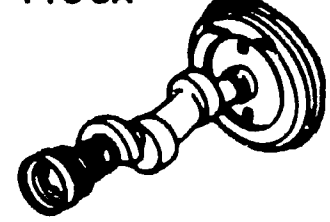
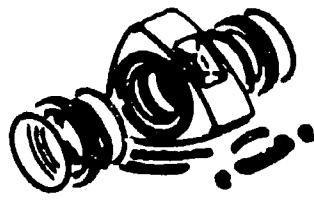

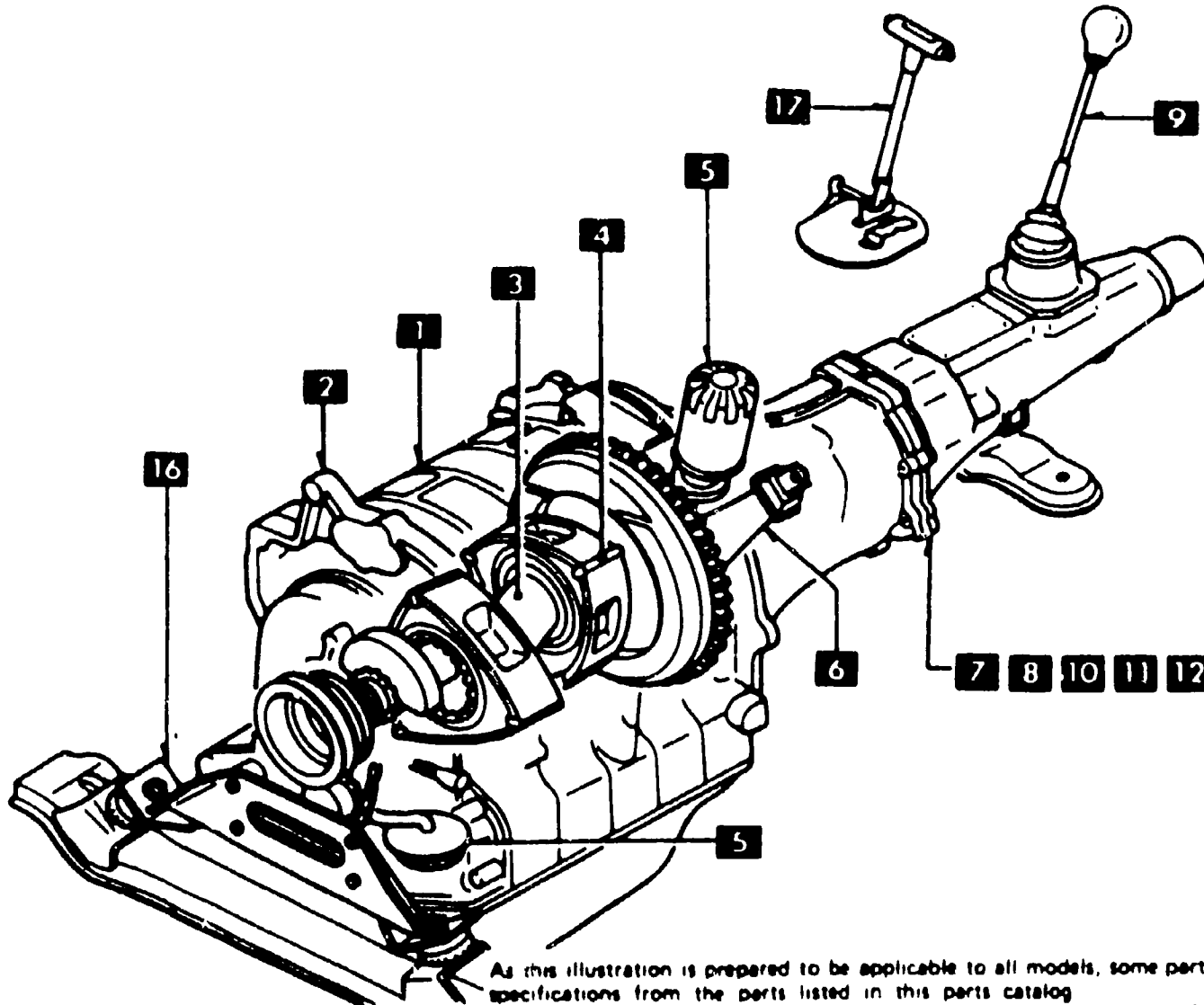
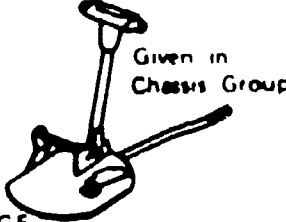
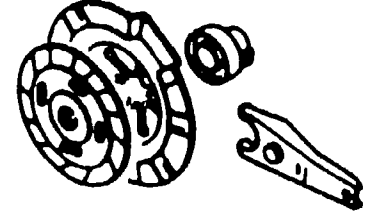
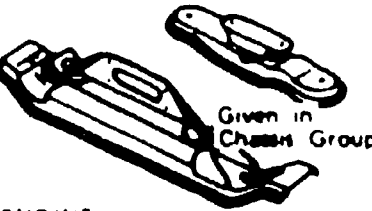
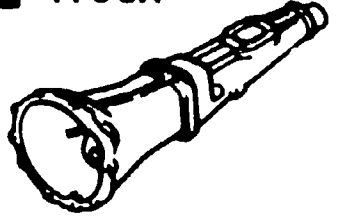

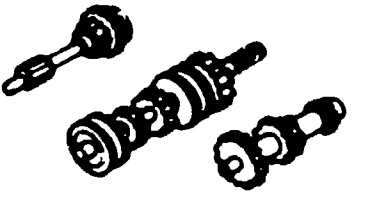

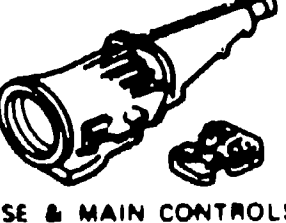
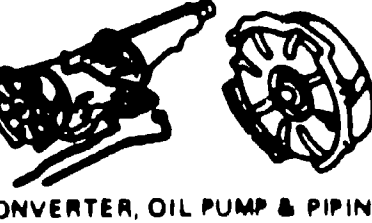
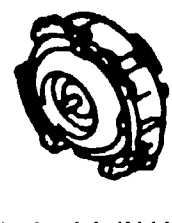



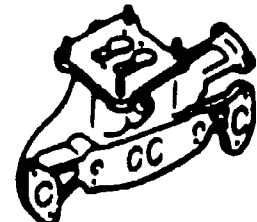
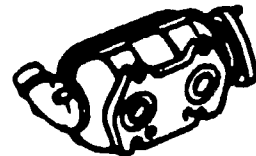

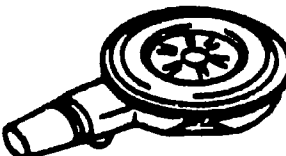

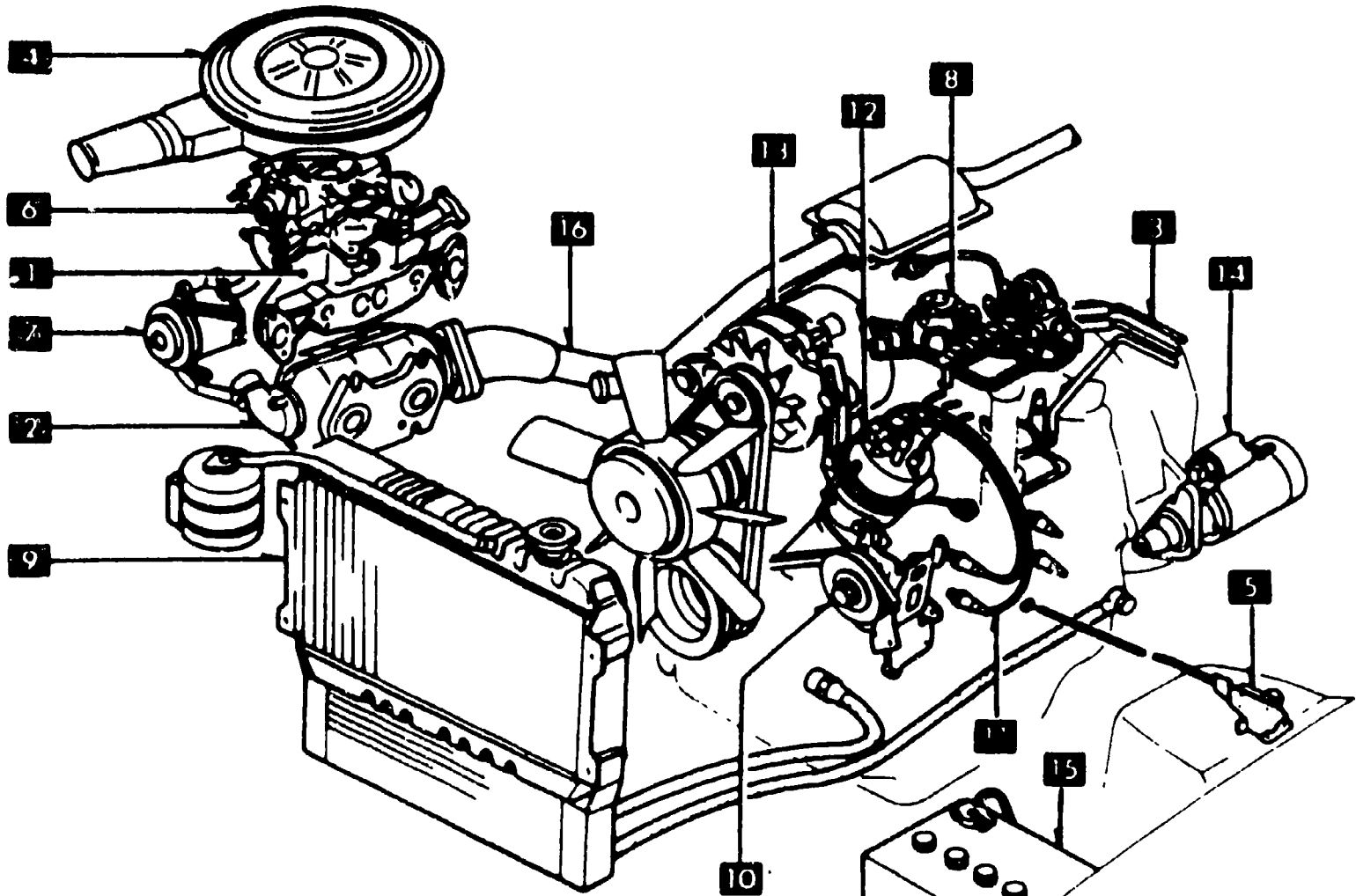
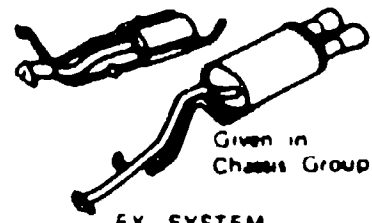
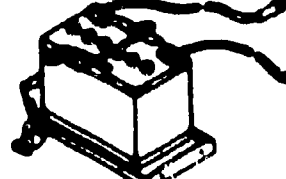
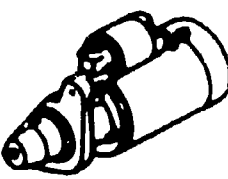

April '92

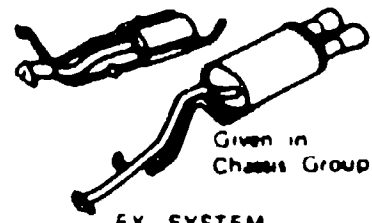
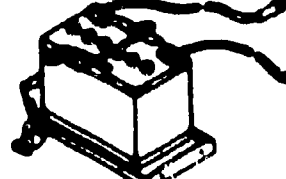
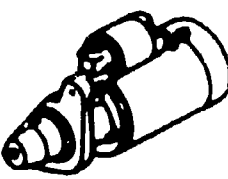
mazda



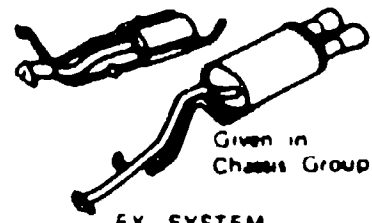
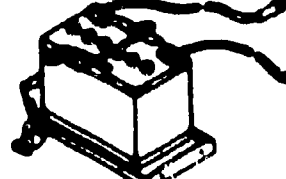
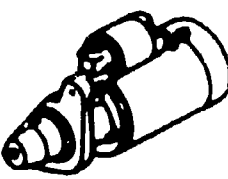

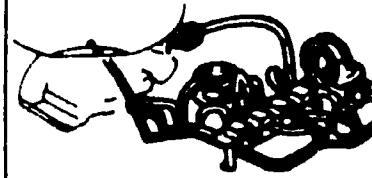
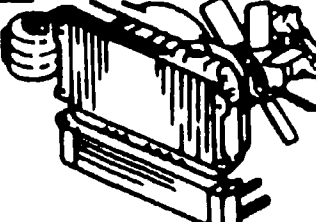
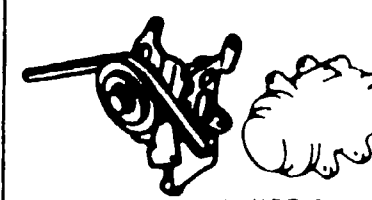

PICTORIAL INDEX

<p>1000A</p>  <p>Engine Gaskets</p>  <p>T/mision Gaskets</p> <p>SHORT ENGINE & GASKET SETS</p>	<p>1 1030A</p>  <p>ROTOR HOUSING</p>	<p>2 1040A</p>  <p>OIL PAN & FRONT & REAR HOUSINGS</p>	<p>3 1100A</p>  <p>ECCENTRIC SHAFT & FLYWHEEL</p>	<p>4 1110A</p>  <p>ROTOR & RELATED</p>	<p>5 1400A</p>  <p>OIL PUMP & FILTER</p>
<p>ROTARY ENGINE (1/2)</p> 					
<p>17 4800A</p>  <p>Given in Chassis Group</p> <p>CHANGE CONTROLS (MANUAL)</p>	<p>As this illustration is prepared to be applicable to all models, some parts are different in specifications from the parts listed in this parts catalog</p>				<p>6 1600A</p>  <p>CLUTCH (MANUAL)</p>
<p>16 3900A</p>  <p>Given in Chassis Group</p> <p>ENGINE & T/MISSION MOUNTINGS</p>					<p>7 1700A</p>  <p>T/MISSION CASE (MANUAL)</p>
<p>15 1950A</p>  <p>MANUAL LINKAGE (AUTOMATIC T/MISSION)</p>					<p>8 1710A</p>  <p>T/MISSION GEARS (MANUAL)</p>
<p>14 1940A</p>  <p>LOW, REVERSE & GOVERNOR (AUTOMATIC T/MISSION)</p>	<p>13 1930A</p>  <p>CLUTCH & PLANETARY GEARS (AUTOMATIC T/MISSION)</p>	<p>12 1920A</p>  <p>CASE & MAIN CONTROLS (AUTOMATIC T/MISSION)</p>	<p>11 1910A</p>  <p>CONVERTER, OIL PUMP & PIPING (AUTOMATIC T/MISSION)</p>	<p>10 1900A</p>  <p>TORQUE GLIDE (MANUAL)</p>	

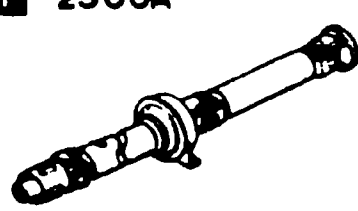
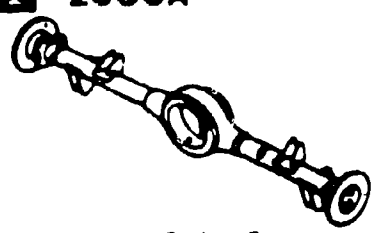

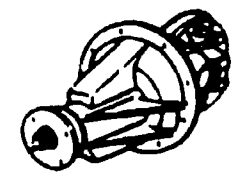
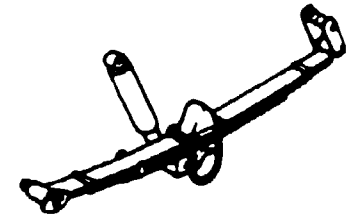
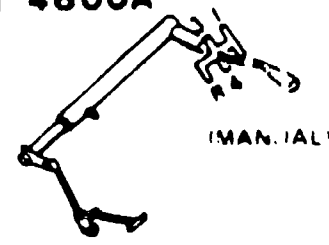
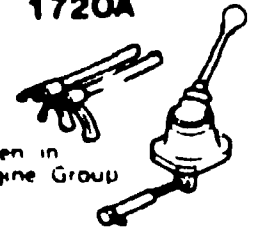
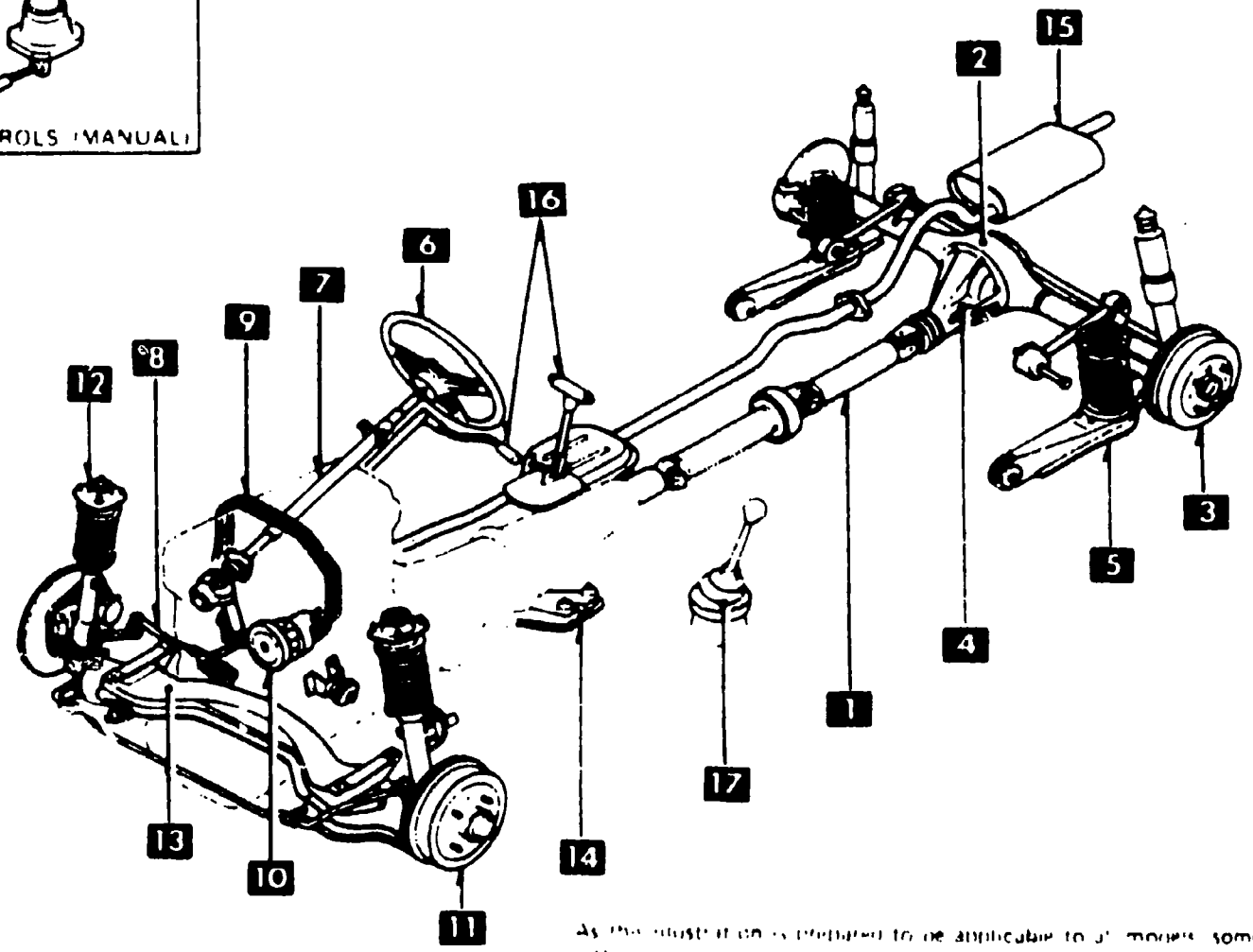

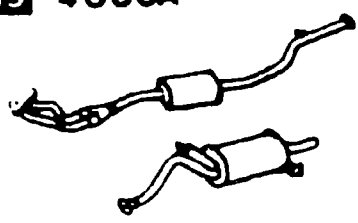
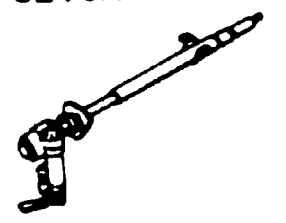
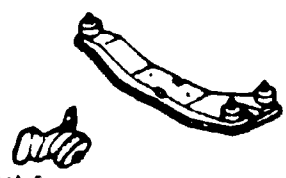
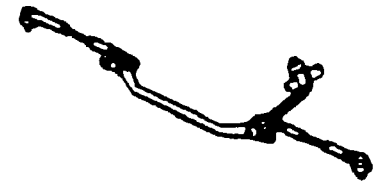
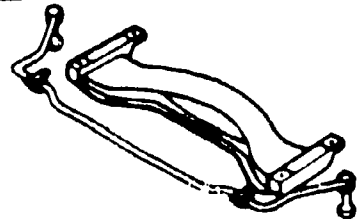
PICTORIAL INDEX

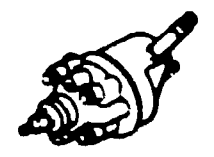
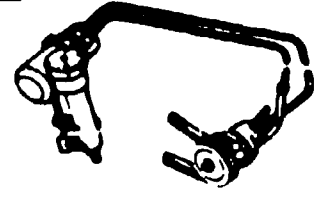
<p>1 1300A</p>  <p>IN MANIFOLD</p>	<p>2 1310A</p>  <p>THERMAL REACTOR</p>	<p>1 1320A</p>  <p>FUEL SYSTEM</p>	<p>1 1330A</p>  <p>AIR CLEANER</p>	<p>1 1350A</p>  <p>STARTING ASSIST SYSTEM</p>	<p>6 1360A</p>  <p>CARBURETOR</p>						
<p>ROTARY ENGINE (2/2)</p>  <p>As this illustration is prepared to be applicable to all models, some parts are different in specifications from the parts listed in this parts catalog</p>											
<table border="1" style="width: 100%; border-collapse: collapse;"> <tr> <td data-bbox="226 1670 636 1964"> <p>16 4000A</p>  <p>Given in Chassis Group</p> <p>EX SYSTEM</p> </td> <td data-bbox="636 1670 1046 1964"> <p>15 1850A</p>  <p>BATTERY & CABLES</p> </td> <td data-bbox="1046 1670 1456 1964"> <p>15 1840A</p>  <p>STARTER</p> </td> <td data-bbox="1456 1670 1866 1964"> <p>13 1830A</p>  <p>ALTERNATOR</p> </td> <td data-bbox="1866 1670 2276 1964"> <p>12 1820A</p>  <p>DISTRIBUTOR</p> </td> <td data-bbox="2276 1670 2700 1964"> <p>11 1800A</p>  <p>V Belt, Spark Plug, Ignition Coil, Regulator</p> <p>ELECTRICAL SYSTEM (ENGINE)</p> </td> </tr> </table>						<p>16 4000A</p>  <p>Given in Chassis Group</p> <p>EX SYSTEM</p>	<p>15 1850A</p>  <p>BATTERY & CABLES</p>	<p>15 1840A</p>  <p>STARTER</p>	<p>13 1830A</p>  <p>ALTERNATOR</p>	<p>12 1820A</p>  <p>DISTRIBUTOR</p>	<p>11 1800A</p>  <p>V Belt, Spark Plug, Ignition Coil, Regulator</p> <p>ELECTRICAL SYSTEM (ENGINE)</p>
<p>16 4000A</p>  <p>Given in Chassis Group</p> <p>EX SYSTEM</p>	<p>15 1850A</p>  <p>BATTERY & CABLES</p>	<p>15 1840A</p>  <p>STARTER</p>	<p>13 1830A</p>  <p>ALTERNATOR</p>	<p>12 1820A</p>  <p>DISTRIBUTOR</p>	<p>11 1800A</p>  <p>V Belt, Spark Plug, Ignition Coil, Regulator</p> <p>ELECTRICAL SYSTEM (ENGINE)</p>						
<p>7 1371A</p>  <p>EMISSION CONTROLS (AIR PUMP & CONTROL VALVE)</p>											
<p>8 1380A</p>  <p>EMISSION CONTROLS (EX SIDE)</p>											
<p>9 1500A</p>  <p>COOLING SYSTEM</p>											
<p>10 1580A</p>  <p>COMPRESSOR BRACKET, PULLEY & BELT (AIR CONDITIONER)</p>											

PICTORIAL INDEX

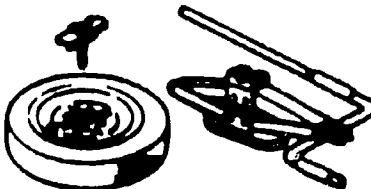
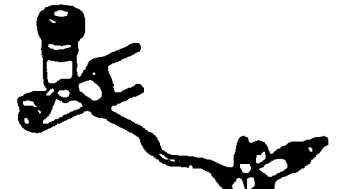
1 2500A  PROPELLER SHAFT	2 2600A  REAR AXLE	3 2610A  REAR BRAKES	4 2700A  DIFFERENTIAL	5 2800A  REAR SUSPENSION	
16 4600A  (MANUAL) CHANGE CONTROLS (MANUAL)	17 1720A  Given in Engine Group CHANGE CONTROLS (MANUAL)	CHASSIS (1/2) 			6 3200A  STEERING WHEEL
15 4000A  EXHAUST SYSTEM	<p style="font-size: small;">As this illustration is prepared to be applicable to all models, some parts are different in specifications from the parts listed in this parts catalog.</p>			7 3210A  STEERING GEAR & COLUMN	
14 3900A  ENGINE & TRANSMISSION MOUNTINGS				8 3230A  STEERING LINKAGE	
13 3410A  CROSSMEMBER & STABILIZER	12 3400A  FRONT SUSPENSION	11 3300A  FRONT AXLE & BRAKES	10 3260A  VANE PUMP - POWER STEERING	9 3240A  POWER STEERING SYSTEM	

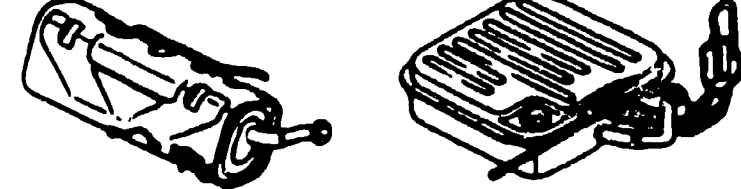
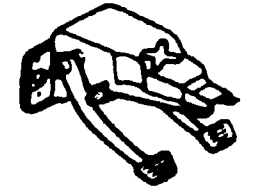
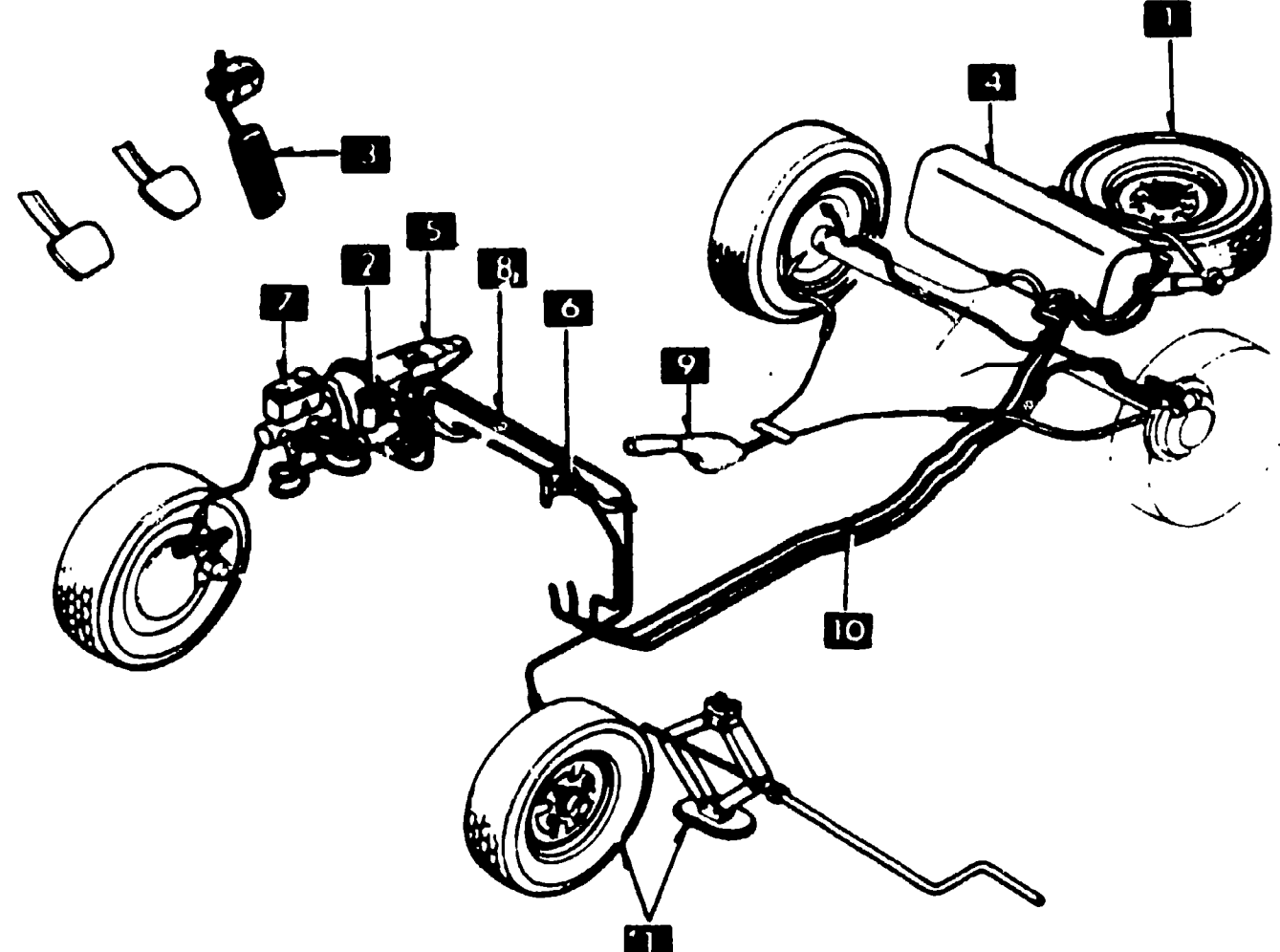
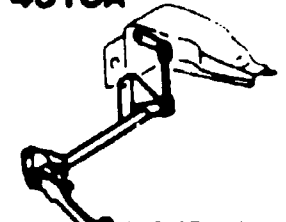
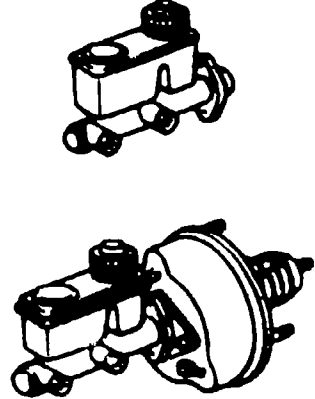
PICTORIAL INDEX

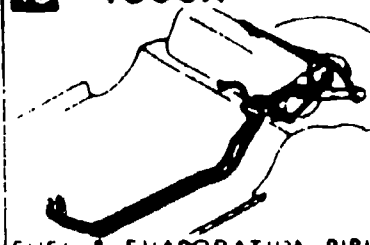
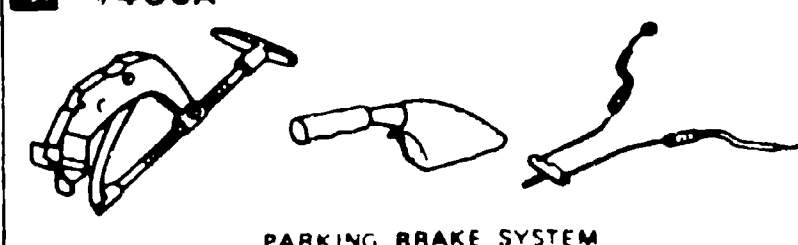
<p>1 3700A</p>  <p>TIRE & JACK</p>	<p>2 4140A</p>  <p>CLUTCH RELEASE & MASTER CYLINDERS</p>	<p>3 4160A</p>  <p>ACCELERATOR CONTROLS</p>	<p>4 4200A</p>  <p>FUEL TANK</p>	<p>5 4300A</p>  <p>CLUTCH & BRAKE</p>	
<p>CHASSIS (2/2)</p>  <p>As this illustration is prepared to be applicable to all models some parts are different in specifications from the parts listed in this parts catalog</p>					<p>6 4310A</p>  <p>ASSIST BRAKE (FOR DRIVING SCHOOL)</p>
					<p>7 4340A</p>  <p>TANDEM MASTER CYL & VACUUM POWER ASSIST SYSTEM</p>
					<p>B 4360A</p>  <p>BRAKE PIPING</p>
					<p>10 4500A</p>  <p>FUEL & EVAPORATION PIPINGS</p>
<p>9 4400A</p>  <p>PARKING BRAKE SYSTEM</p>					

PICTORIAL INDEX

1 0900A

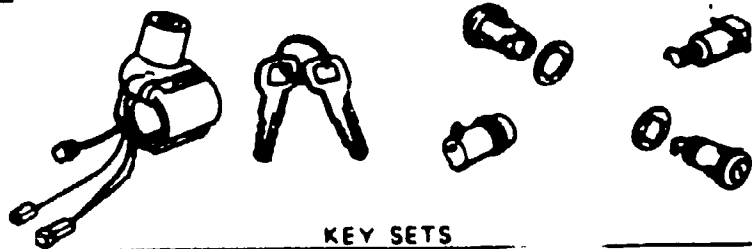

KEY SETS

2 5020A

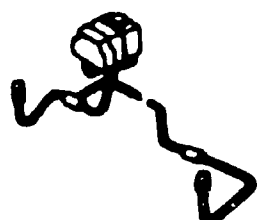

HEAD LAMP CLEANER

3 5100A

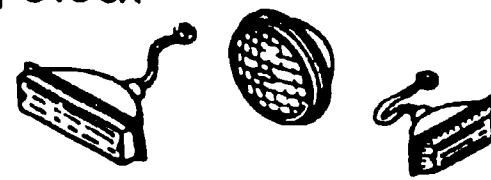

LAMPS (FRONT & SIDE)

4 5110A



LAMPS (REAR & INTERIOR)

5 5130A

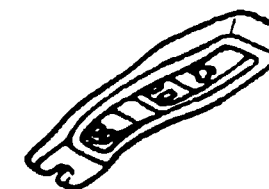

OVERHEAD CONSOLE

6 6600A

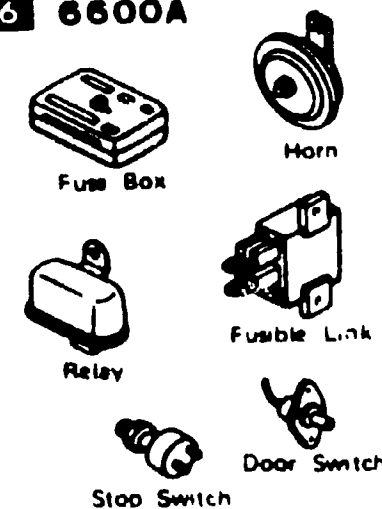

ELECTRIC EQUIPMENT (BODY)

7 6680A

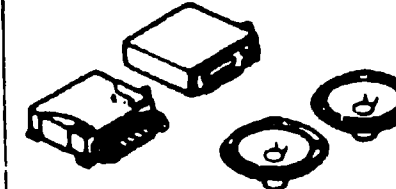

RADIO & STEREO SYSTEMS

BODY(1/3)

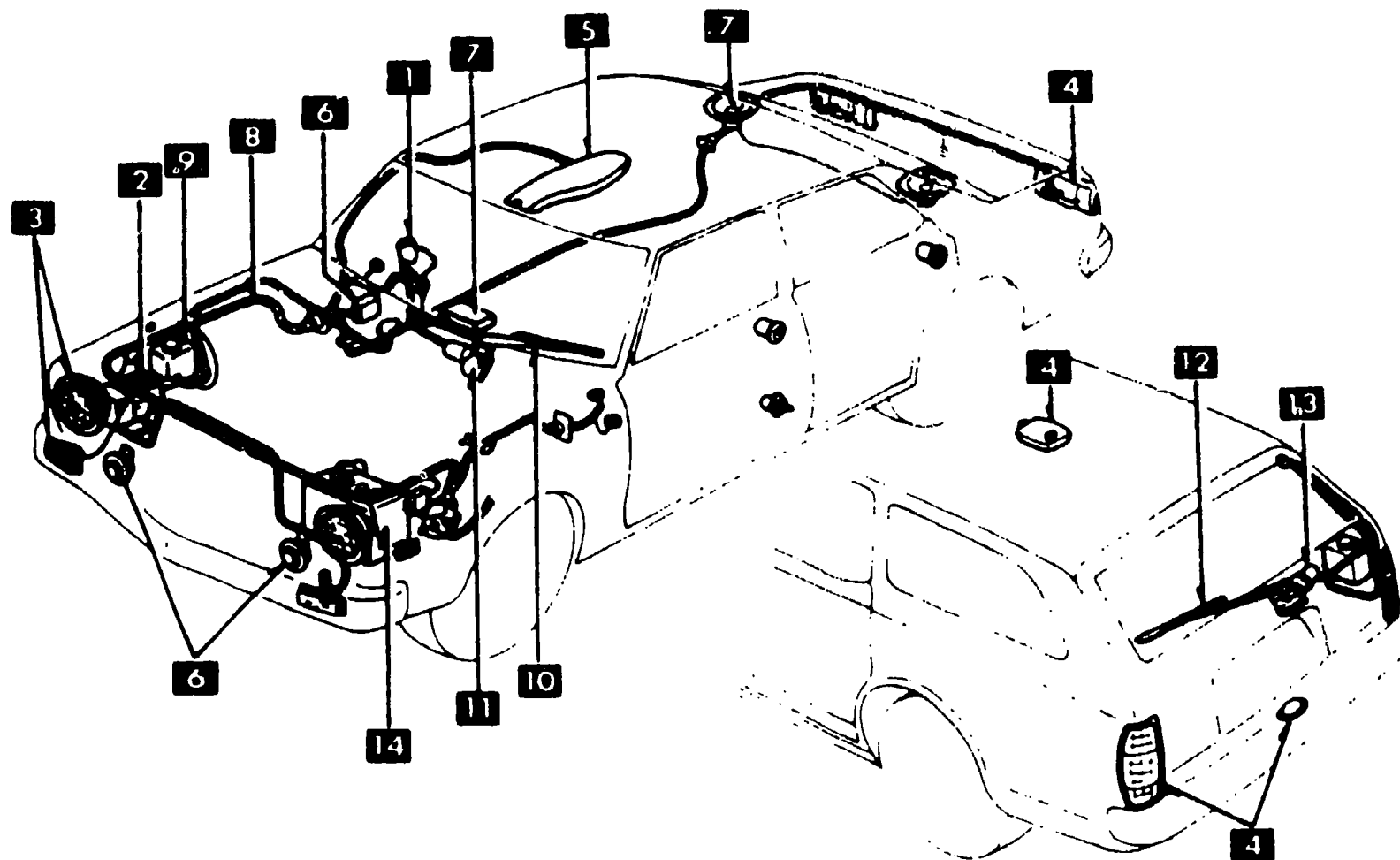

As this illustration is prepared to be applicable to all models some parts are different in specifications from the parts listed in this parts catalog

14 1850A

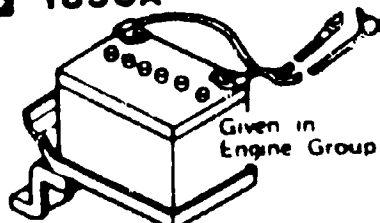

Given in Engine Group

BATTERY & CABLES

13 6760A



REAR WINDOW WIPER MOTOR (COMPONENTS ONLY)

12 6750A

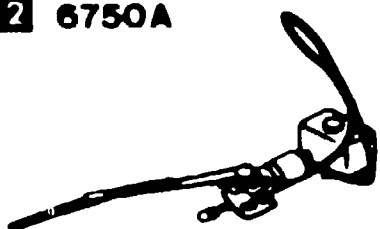

REAR WINDOW WIPER & WASHER

11 6740A



WIPER MOTOR (COMPONENTS ONLY)

10 6730A



WINDSHIELD WIPER

9 6720A

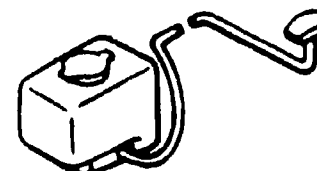





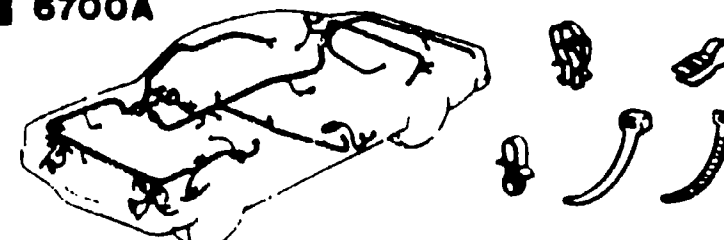

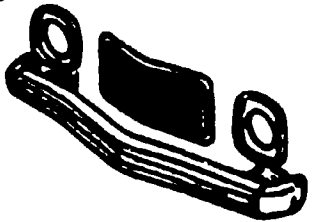
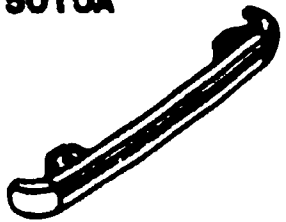
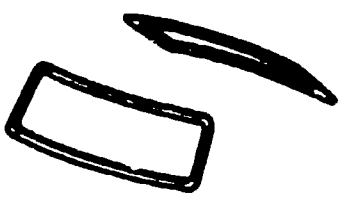
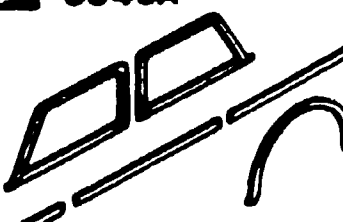
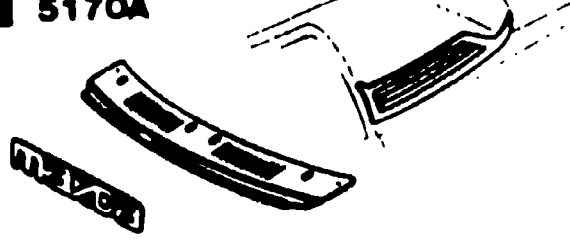
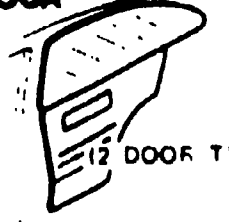
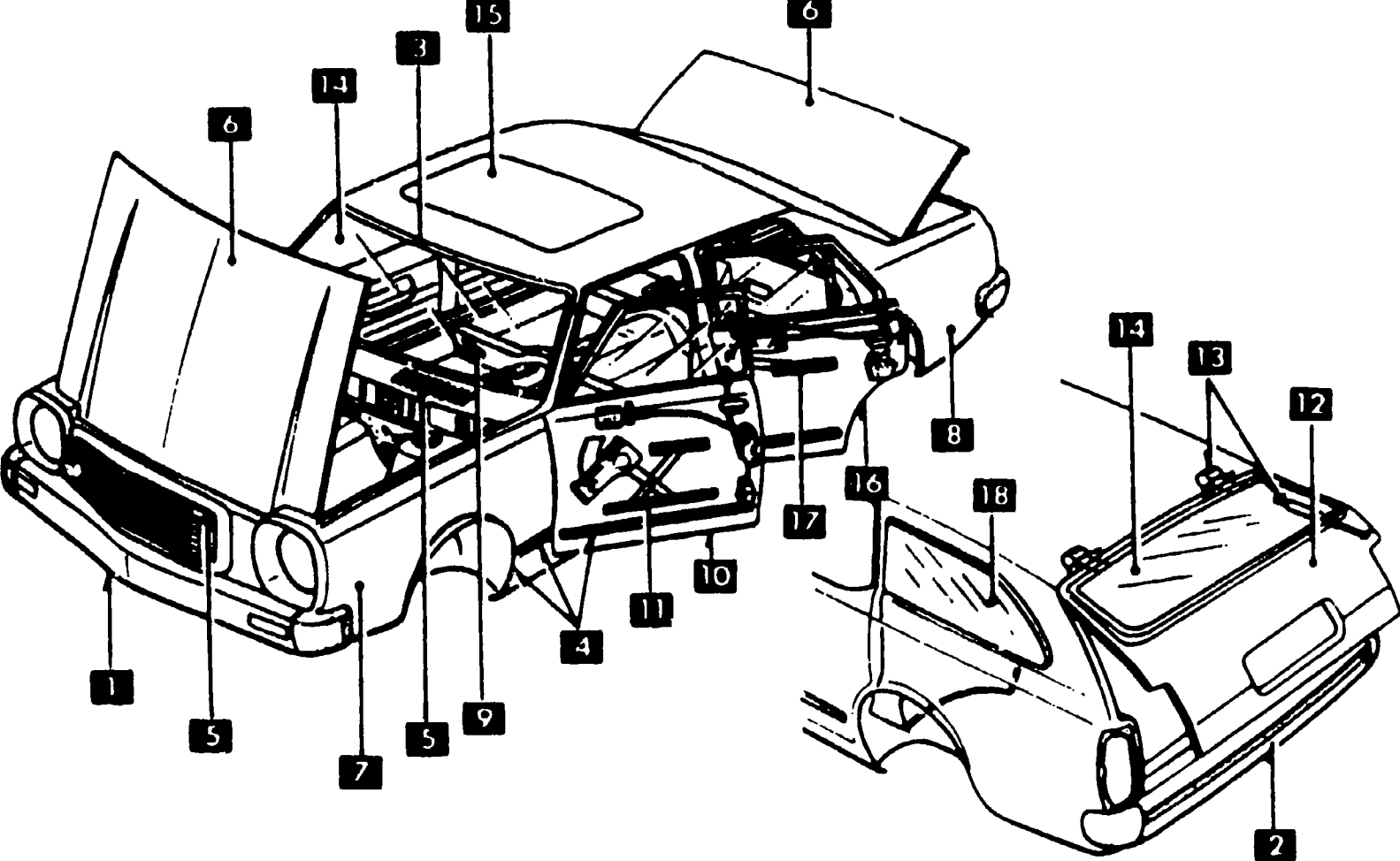
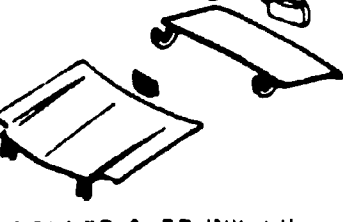

WINDSHIELD WASHER

8 6700A

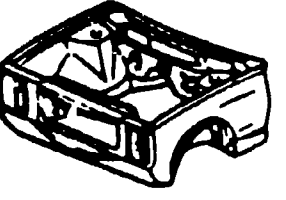

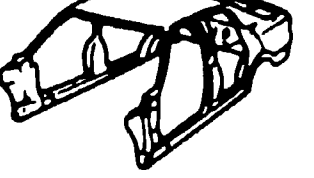
WIRE HARNESS & CLAMPS

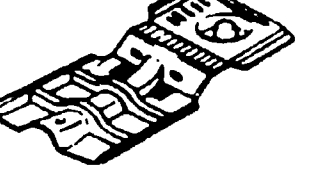
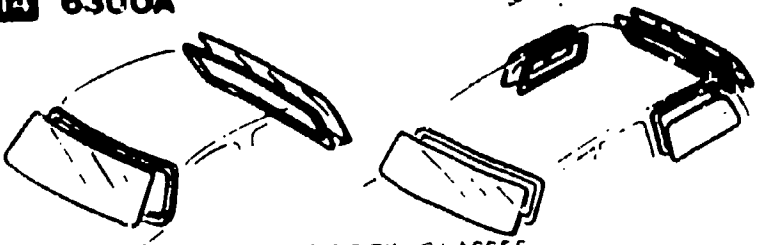
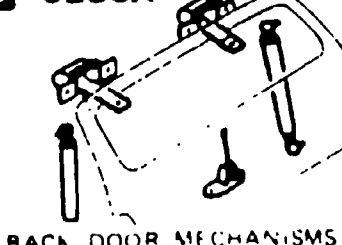
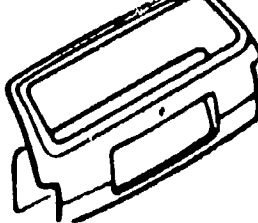
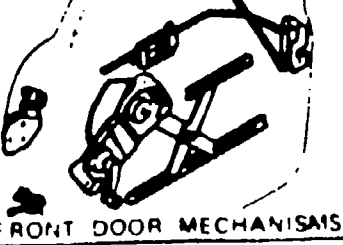
PICTORIAL INDEX

1 5000A  FRONT BUMPER & GRILLE	2 5010A  REAR BUMPER	3 5030A  WINDOW MOULDINGS	4 5040A  BODY MOULDINGS	5 5170A  COWL & EXTRACTOR GRILLES & ORNAMENTS
18 7250A  REAR WINDOW GLASS & TRIM <small>(2 DOOR TYPE)</small>	BODY(2/3) 			6 5230A  BONNET & TRUNK LID
17 7230A  REAR DOOR MECHANISMS				7 5310A  BODY PANELS (FRONT)
16 7200A  REAR DOOR				8 5340A  BODY PANELS (SIDE & ROOF)
15 6330A  SUNROOF				9 5360A  BODY PANELS (FLOOR)
14 6300A  WINDOW GLASSES	13 6230A  BACK DOOR MECHANISMS	12 6200A  BACK DOOR	11 5830A  FRONT DOOR MECHANISMS	10 5800A  FRONT DOOR

As this illustration is prepared to be applicable to all models, some parts are different in specifications from the parts listed in this parts catalog

PICTORIAL INDEX

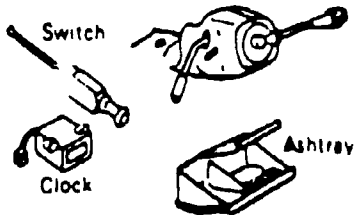
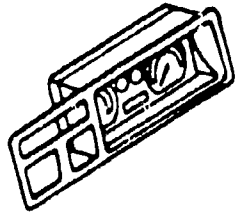
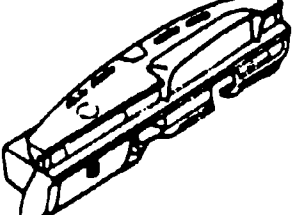
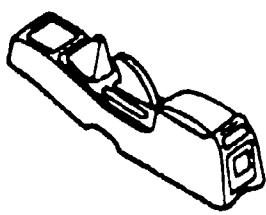
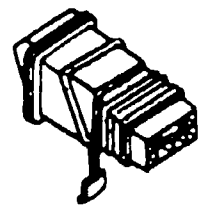
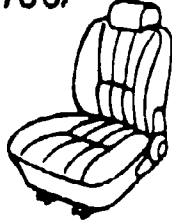
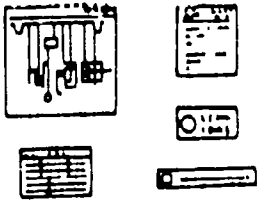
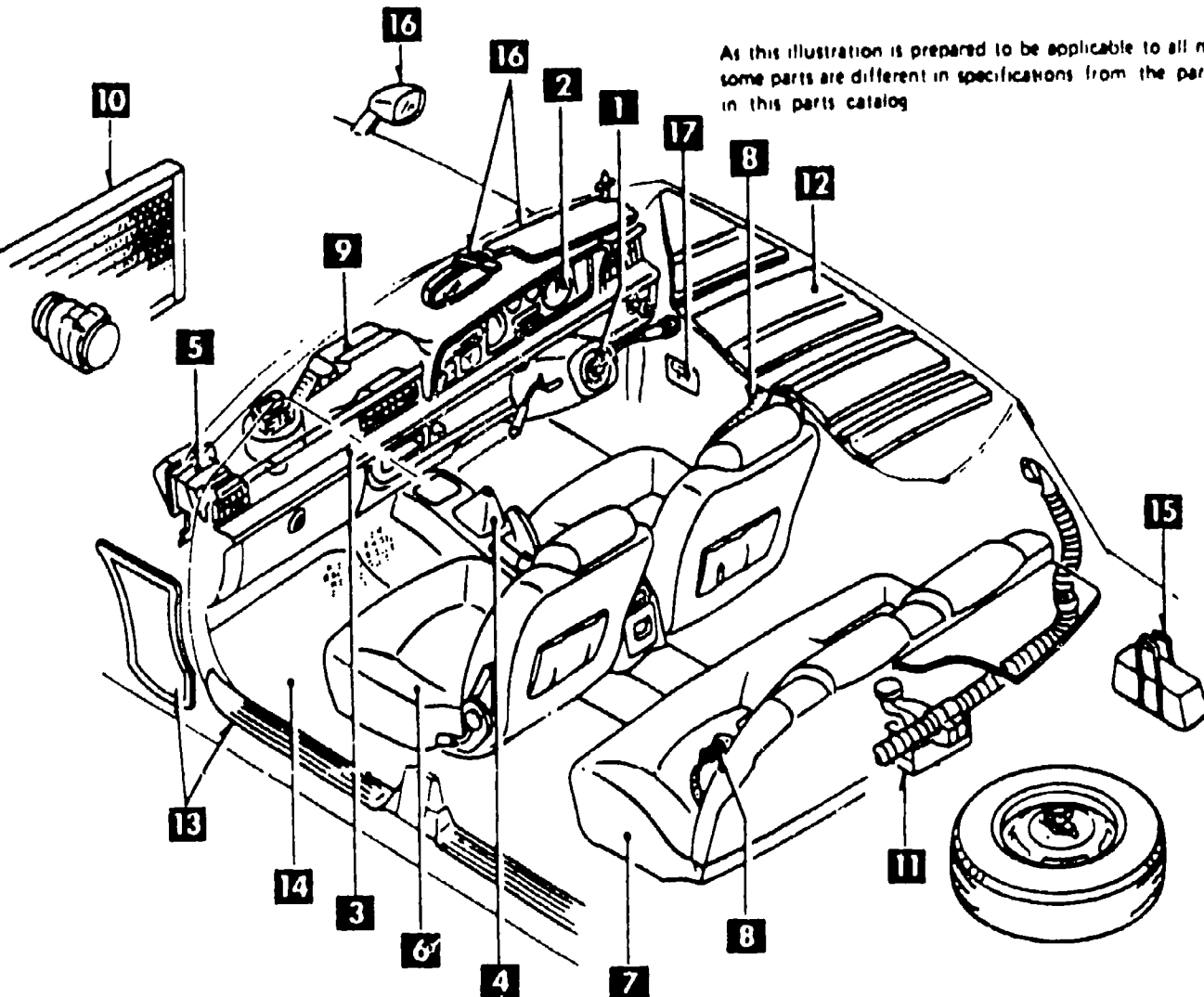
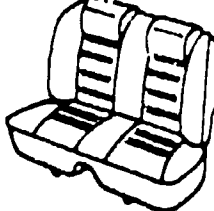
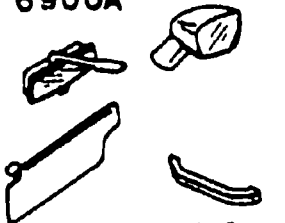
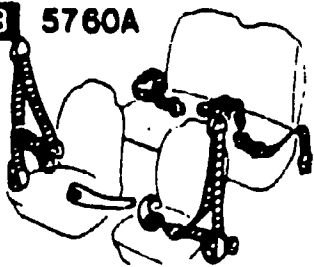
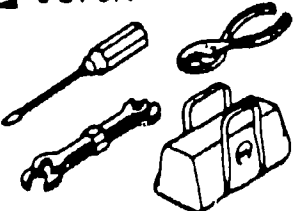
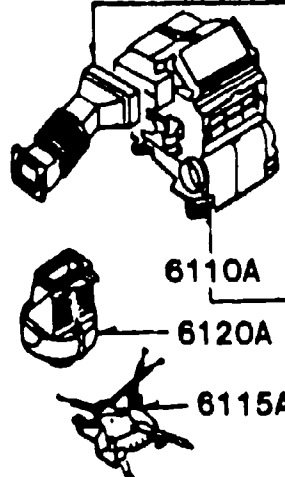
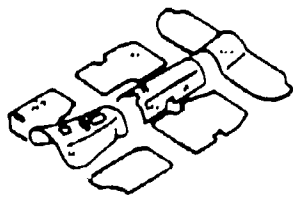
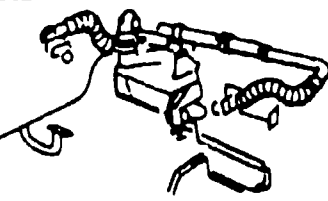
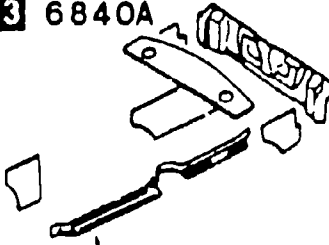
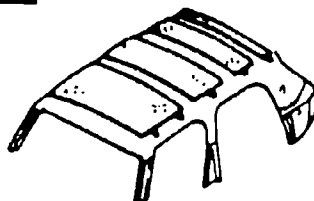
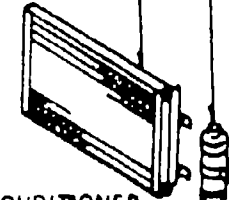
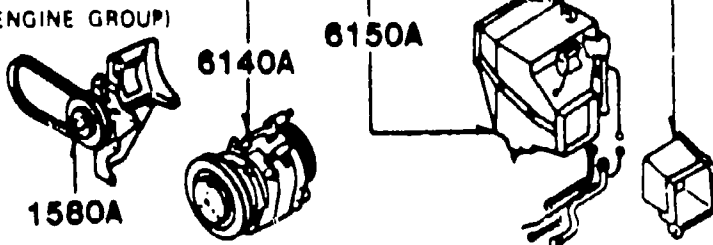
<p>1 5500A</p>  <p>DASHBOARD EQUIPMENT</p>	<p>2 5540A</p>  <p>METERS</p>	<p>3 5560A</p>  <p>DASHBOARD & RELATED</p>	<p>4 5570A</p>  <p>CONSOLE</p>	<p>5 5580A</p>  <p>VENTILATOR</p>	<p>6 5700A</p>  <p>FRONT SEAT</p>
<p>17 6930A</p>  <p>CAUTION PLATES</p>	<p>BODY(3/3)</p>  <p style="font-size: small;">As this illustration is prepared to be applicable to all models, some parts are different in specifications from the parts listed in this parts catalog</p>				<p>7 5720A</p>  <p>REAR SEAT</p>
<p>16 6900A</p>  <p>VISOR, ASSIST HANDLE & MIRRORS</p>					<p>8 5760A</p>  <p>SEAT BELTS</p>
<p>15 6870A</p>  <p>SERVICE TOOLS</p>					<p>9 6100A</p>  <p>HEATER</p>
<p>14 6860A</p>  <p>FLOOR MATS & PADS</p>					<p>11 6180A</p>  <p>REAR COOLER</p>
<p>13 6840A</p>  <p>TRIM & SCUFF PLATE</p>	<p>12 6880A</p>  <p>CEILING TRIM</p>	<p>10 6130A</p>  <p>AIR CONDITIONER</p>	<p>(ENGINE GROUP)</p>  <p>1580A 6140A 6150A</p>		

MODEL IDENTIFICATION

MAZDA RX-7

(1981 MODELS MANUFACTURED FROM JULY 1980.)

(1982 MODELS MANUFACTURED FROM MAY 1981.)

(1983 MODELS MANUFACTURED FROM JULY 1982.)

MDL NO.	STATE		ENG	T/ M		BRAKE		ROOF		YEAR				VIN
	C A L I F O R N I A	F E D E R A L	R O T A R Y 12A	M A N U A L 5 S P E E D	A U T O M A T I C	F R O N T D I S C	4 W H E E L D I S C	S U M M E R R O O F	N O R M A L R O O F	1	1	1	1	
										9	8	8	8	
FA02	CAL		12	58		F			N/R	X				FB331-500001-600000
FA03	CAL		12	58		F		S/R		X				FB331-500001-600000
FA04	CAL		12		A/T	F			N/R	X				FB331-500001-600000
FA05	CAL		12		A/T	F		S/R		X				FB331-500001-600000
FA20	CAL		12	58			F/R	S/R		X				FB331-500001-600000
FA21	CAL		12		A/T		F/R	S/R		X				FB331-500001-600000

MODEL IDENTIFICATION

MAZDA RX-7

(1981 MODELS MANUFACTURED FROM JULY 1980.)

(1982 MODELS MANUFACTURED FROM MAY 1981.)

(1983 MODELS MANUFACTURED FROM JULY 1982.)

MDL NO.	STATE		ENG	T/ M		BRAKE		ROOF		YEAR				VIN
	C A L I F O R N I A	F E D E R A L	R O T A R Y 12A	M A N U A L 5 S P E E D	A U T O M A T I C	F R O N T D I S C	4 W H E E L D I S C	S U M M E R R O O F	N O R M A L R O O F	1	1	1	1	
										9	8	8	8	
FA07		FED	12	58		F			N/R	X				FB331-500001-600000
FA08		FED	12		A/T	F			N/R	X				FB331-500001-600000
FA09		FED	12	58		F		S/R		X				FB331-500001-600000
FA10		FED	12		A/T	F		S/R		X				FB331-500001-600000
FA18		FED	12	58			F/R	S/R		X				FB331-500001-600000
FA19		FED	12		A/T		F/R	S/R		X				FB331-500001-600000
FA32	CAL		12	58		F			N/R		X			FB331-600001-700000

MODEL IDENTIFICATION

MAZDA RX-7

(1981 MODELS MANUFACTURED FROM JULY 1980.)

(1982 MODELS MANUFACTURED FROM MAY 1981.)

(1983 MODELS MANUFACTURED FROM JULY 1982.)

MDL NO.	STATE		ENG	T/M		BRAKE		ROOF		YEAR				VIN
	CALIFORNIA	FEDERAL	ROTARY	MANUAL	AUTOMATIC	FRONT DISC	4 WHEEL DISC	SUMEROOF	NORMAL ROOF	1981	1982	1983	1984	
FA34	CAL		12A	58		F		S/R			X			FB331-600001-700000
FA35	CAL		12		A/T	F		S/R			X			FB331-600001-700000
FA40	CAL		12	58		F/R	S/R				X			FB331-600001-700000
FA41	CAL		12		A/T	F/R	S/R				X			FA331-600001-700000
FA30		FED	12	58		F			N/R		X			FA331-600001-700000
FA31		FED	12		A/T	F			N/R		X			FB331-600001-700000

MODEL IDENTIFICATION

MAZDA RX-7

(1981 MODELS MANUFACTURED FROM JULY 1980.)

(1982 MODELS MANUFACTURED FROM MAY 1981.)

(1983 MODELS MANUFACTURED FROM JULY 1982.)

MDL NO.	STATE		ENG	T/M		BRAKE		ROOF		YEAR				VIN
	CALIFORNIA	FEDERAL	ROTARY	MANUAL	AUTOMATIC	FRONT DISC	4 WHEEL DISC	SUMEROOF	NORMAL ROOF	1981	1982	1983	1984	
FA36		FED	12	58		F		S/R				X		FB331-600001-700000
FA37		FED	12		A/T	F		S/R				X		FB331-600001-700000
FA38		FED	12	58		F/R	4/R					X		FB331-600001-700000
FA39		FED	12		A/T	F/R	S/R					X		FB331-600001-700000
FA42		FED	12	58		F			N/P				X	FB331-700000-
FA43		FED	12		A/T	F			N/R				X	FB331-700000-
FA46		FED	12	58		F		S/R					X	FB331-700000-

MODEL IDENTIFICATION

MAZDA RX-7

(1981 MODELS MANUFACTURED FROM JULY 1980.)

(1982 MODELS MANUFACTURED FROM MAY 1981.)

(1983 MODELS MANUFACTURED FROM JULY 1982.)

MDL NO.	STATE		ENG	T/ M		BRAKE		ROOF		YEAR				VIN
	CALIFORNIA	FEDERAL	ROTARY	MANTIC	AUTOMATIC	FRONT DISC	4 WHEEL DISC	SUNROOF	NORMAL ROOF	1981	1982	1983	1984	
FA47		FED	12		A/T	F		S/R				X		FB331-700001-
FA48		FED	12	58			F/R	S/R				X		FB331-700001-
FA49		FED	12		A/T		F/R	S/R				X		FB331-700001-
FA44	CAL		12	58		F		N/R				X		FB331-700001-
FA45	CAL		12		A/T	F		N/R				X		FB331-700001-
FA50	CAL		12	58		F		S/R				X		FB331-700001-
FA51	CAL		12		A/T	F		S/R				X		FB331-700001-
FA52	CAL		12	58			F/R	S/R				X		FB331-700001-
FA53	CAL		12		A/T		F/R	S/R				X		FB331-700001-

LIST OF MONTHLY STARTING VIN (CHASSIS NO.)

LIST OF COMPLETE ASSEMBLY UNIT'S PART NUMBERS

'81 MODEL

MODEL	YR./MO.	JAN. 80/1	FEB. 80/2	MAR. 80/3	APR. 80/4	MAY 80/5	JUN. 80/6	JUL. 80/7	AUG. 80/8	SEP. 80/9	OCT. 80/10	NOV. 80/11	DEC. 80/12
RX-7						500001	500076	503736	507335	510973	514495
FB331													

'81 MODEL

MODEL	YR./MO.	JAN. 81/1	FEB. 81/2	MAR. 81/3	APR. 81/4	MAY 81/5	JUN. 81/6	JUL. 81/7	AUG. 81/8	SEP. 81/9	OCT. 81/10	NOV. 81/11	DEC. 81/12
RX-7										
FB331		518602	521856	525552	529439	533094							

'82 MODEL

MODEL	YR./MO.	JAN. 81/1	FEB. 81/2	MAR. 81/3	APR. 81/4	MAY 81/5	JUN. 81/6	JUL. 81/7	AUG. 81/8	SEP. 81/9	OCT. 81/10	NOV. 81/11	DEC. 81/12
RX-7				600001	605900	610656	613699	618135	622566	626755
FB331													

'82-'83 MODEL

MODEL	YR./MO.	JAN. 82/1	FEB. 82/2	MAR. 82/3	APR. 82/4	MAY 82/5	JUN. 82/6	JUL. 82/7	AUG. 82/8	SEP. 82/9	OCT. 82/10	NOV. 82/11	DEC. 82/12
RX-7													
FB331		629395	633361	637250	642150	647749	652186	700132	703771				

COMPLETE MODEL NO.	ENGINE	TRANSMISSION	REAR AXLE	CABIN	REMARKS
FA42	K231-02-000	K528-03-000	P023-05-000	FA42-07-000	Federal N/T Normal roof Front disc brake only
FA43	K232-02-000	A109-19-000	P023-05-000	FA42-07-000	Federal A/T Normal roof Front disc brake only
FA46	K231-02-000	K528-03-000	P023-05-000	FA46-07-000	Federal N/T Sunroof Front disc brake only
FA47	K232-02-000	A109-19-000	P023-05-000	FA46-07-000	Federal A/T Sunroof Front disc brake only
FA48	K231-02-000	K528-03-000	P026-05-000	FA46-07-000	Federal N/T Sunroof Front & rear disc brake
FA49	K232-02-000	A109-19-000	P026-05-000	FA46-07-000	Federal A/T Sunroof Front & rear disc brake
FA44	K233-02-000	K528-03-000	P023-05-000	FA42-07-000	California N/T Normal roof Front disc brake only
FA45	K234-02-000	A109-19-000	P023-05-000	FA42-07-000	California A/T Normal roof Front disc brake only
FA50	K233-02-000	K528-03-000	P023-05-000	FA46-07-000	California N/T Sunroof Front disc brake only
FA51	K234-02-000	A109-19-000	P023-05-000	FA46-07-000	California A/T Sunroof Front disc brake only
FA52	K233-02-000	K528-03-000	P026-05-000	FA46-07-000	California N/T Sunroof Front & rear disc brake
FA53	K234-02-000	A109-19-000	P026-05-000	FA46-07-000	California A/T Sunroof Front & rear disc brake

NOTE: Complete assemblies are available and manufactured in accordance with current production specifications only.

INSTRUCTIONS

HOW TO LOCATE PARTS IN THE CATALOG

Realistically, there can only be four possible scenarios when looking for a part(s). These are:

1. Either image of the part or the location on vehicle are known.
2. D-Code and/or Group number (of part) are known.
3. Part Number is known.
4. Name of part is known.

If one or more of the items listed above are known, the parts catalog user may use the appropriate index to facilitate part(s) location. The four indexes that may be used are:

PICTORIAL INDEX -

Use if either the image of the part and/or location on vehicle are known.

SECTION NUMBER INDEX -

Use if D-Code, Group Number or type of part is known.

PART NUMBER INDEX -

Use if part number is known.

ALPHABETICAL INDEX -

Use if name of part is known.

The following two pages outline how to use these indexes.

USING THE PICTORIAL INDEX

1. The PICTORIAL INDEX is the 1st column of every fiche.
2. Decide whether the desired part is an engine, chassis or body part.
3. Look through the PICTORIAL INDEX for the part. Take note of all possible fiche locations where the part may be found. This information will be useful in thoroughly tracking down the part.
4. Once the appropriate illustration is found, note the section number. Refer to the SECTION NUMBER INDEX for fiche location.

USING THE SECTION NUMBER INDEX

1. The SECTION NUMBER INDEX is the first row of every fiche.
2. The column labeled STARTING LOCATION denotes the microfiche GRID LOCATION for a particular section.

EXAMPLE:

1 - G6

1 = denotes the fiche number, i.e., 1 of 3, 2 of 3, 3 of 3

G = denotes the horizontal row location

6 = denotes the vertical column location

3. As an additional feature, the sections located in every column are enclosed in a "highlight box" in the SECTION NUMBER INDEX.
4. At this point, it is just a simple matter of going to the correct frame and locating the desired part number.

USING THE PART NUMBER INDEX

1. If the part number is known, simply use the PART NUMBER INDEX.
2. The PART NUMBER INDEX is located at the very end of the catalog, on the last fiche of a fiche set.
3. The index shows the section number and the grid location where the part number may be found.
4. When the PART NUMBER INDEX is used, remember that the part number is NOT read from "left to right". The base part number is read first. The base part number consists of the center two digits plus the next three (or four) digits to the right.
5. Use the grid location to go to the appropriate frame where the part number may be found. Cross-reference the part number with the illustration and text to ensure that it is indeed the desired part.

USING THE ALPHABETICAL INDEX

1. If the name of the part is known, simply use the ALPHABETICAL INDEX.
2. The ALPHABETICAL INDEX is located right before the PART NUMBER INDEX, at the very end of the catalog, on the last fiche of a fiche set.
3. The ALPHABETICAL INDEX contains the section number and the grid location where the desired part may be found.
4. Use the grid location to go to the appropriate frame where the part number may be found. Cross-reference the part number with the illustration and text to ensure that it is indeed the desired part.

HOW TO INTERPRET THE ILLUSTRATION

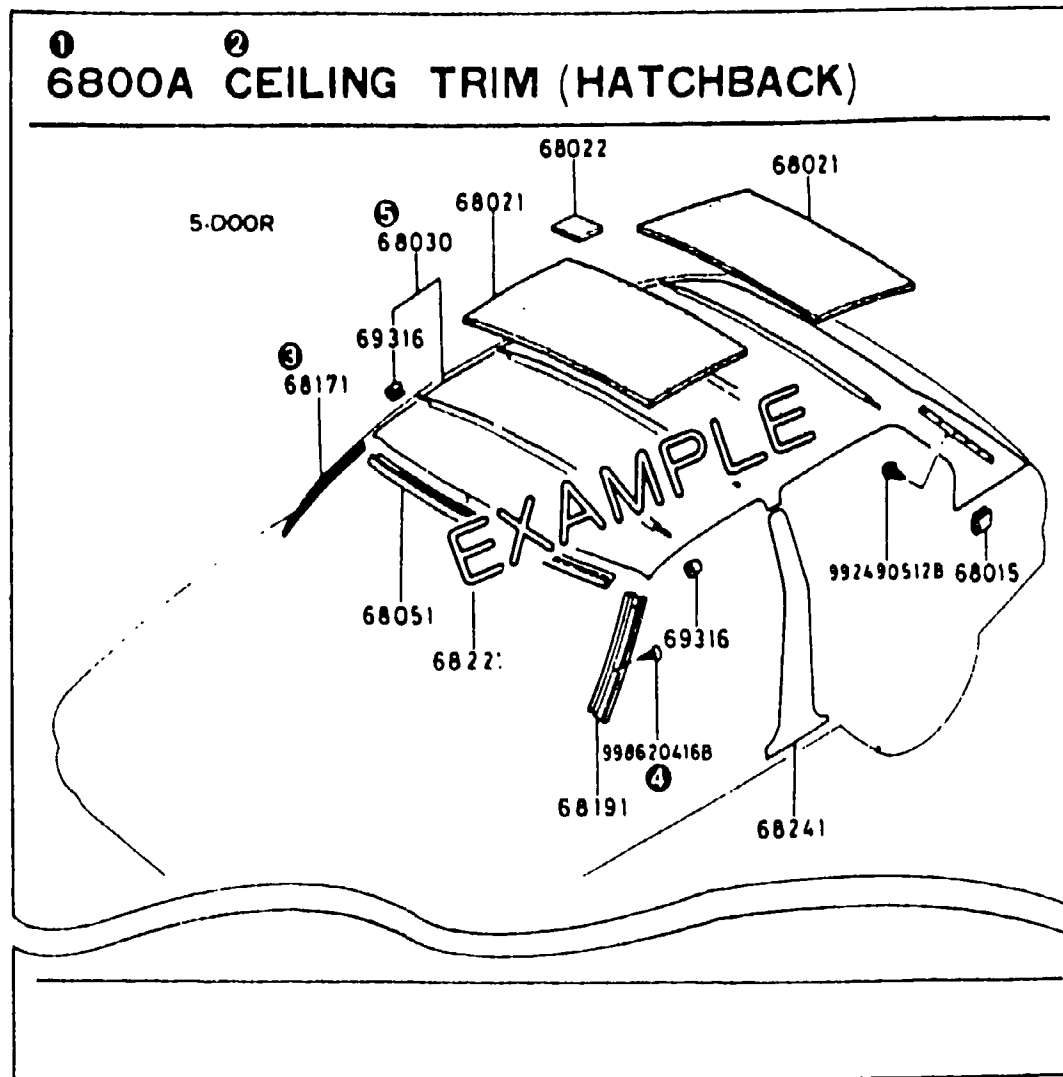

In the example shown above, the interpretation of each item appearing in the illustration area is as follows.

1 SECTION NUMBER

Each illustration is given a Section Number, which is a "IDENTIFICATION NUMBER" of the group of parts classified in function.

Section Number basically consists of four numeric characters and alpha "A". But when a Section (a group of parts) is shown in more than one illustration over the same catalog, an additional alphabetical character is incorporated, e.g.,

Section No.	Section Name
6800A	Ceiling Trim (Hatchback)
6800AA	Ceiling Trim (Wagon)

(Note)
 Illustrations are always arranged in numerical sequence by SECTION NUMBER throughout the fiches in the set. (Exception: Section No. "0900A key Sets" is located in the first section of Body group.)

2 SECTION NAME

This is a descriptive name of the illustration (the group of parts).

3 D-CODE (KEY NUMBER)

D-Code consists of five or six digits, and serves as a "KEY NUMBER" to co-ordinate a part's illustration with its related text.

(Note)

Those parts which appear in the illustration without D-Code are not available as spare parts. (Exception: Most Standard Parts do not have D-Code, but are available as spare parts.)

4 STANDARD PART NUMBER

Those parts which are standardized in form, dimension, material, etc. such as bolts, nuts, washers, etc. are called "Standard Parts". In most cases, Standard Part Numbers are shown on the illustration instead of via the D-Code, and are distinguished from D-Code by the number which consists of nine or ten digits starting with "9", e.g., 99862-0416B. Those Parts do not appear in the text and part number index.

5 ASSEMBLY AND COMPONENTS' RELATIONSHIP

The relationship between an Assembly and its Components is indicated in the illustration but not in the text.

If the D-Code appeared as the example, the correct interpretation of that would be: D-Code 68030 includes D-Code 69316 and Top Ceiling (no D-Code indicated).

HOW TO INTERPRET THE TEXT

IMPORTANT

As there are many abbreviated words used in the text, refer to "Abbreviation List" located in the lower corner of each fiche (frame No. N1).

6800A-1 CEILING TRIM (HATCHBACK)

D-CODE (Key No.)	PART NAME	PART No.	Qty	MODEL/DESCRIPTION	VIN (Chassis No.)
① 68030	② CEILING, TOP	③ 8531-68-030	④ 1	⑤ (USE W/DEFROSTER) 3-DOOR ⑥	
	⑦ BLACK	⑧ 00			
	BEIGE	31			
	BLACK	00		⑨ (USE W/O DEFROSTER) 5-DOOR	
	BEIGE	31			
68051	PLATE, T/CEILING	0531-68-051	1		FA4PS... 500001 -522626 FA4TS... 500001 -688439 ⑩ FA4PS... 522627- FA4TS... 688440-
	<AN>	⑪ *8531-68-051A	1		

In the example shown above, the interpretation of the information appearing in each column is as follows.

① D-CODE (KEY NUMBER)

This is to serve as a "KEY NUMBER" to co-ordinate with a part on the illustration. Those parts which are identical in function and descriptive name, are given a common code over the Mazda Spare Parts. Within each Section Number, the D-Code appears in numerical sequence.

② PART NAME

Part Names are shown in English and/or French and/or Spanish and/or German, depending upon Catalogs and are given to each "D-CODE".

③ COLOR NAME

Color Names appear here when Color Codes are indicated in the "PART No." column. These are shown in English only.

④ PART NUMBER

Under the same D-Code, if there are more than one Part Number, Part Numbers are always listed in numerical and/or alphabetical sequence regardless of the order of modification history of parts.

⑤ COLOR CODE

When Color Code(s) appear(s), the indicated Part Number requires the Color Code to properly identify the color of the part, e.g., 8531-68-030 00, 8531-68-030 31.

⑥ QUANTITY

This denotes the Quantity of each part number per the D-Code used on the applicable model(s).

⑦ DESCRIPTION

An additional descriptive information for each part is provided as necessary.

⑧ MODEL APPLICATION

Model Application for a part is shown in this column if necessary. If there is no Model Application indicated, the affected part is applicable to "ALL MODELS" covered in the page. For further information, refer to "HOW TO INTERPRET THE MODEL APPLICATION" shown later (frame No. G16).

⑨ INTERCHANGEABILITY CODE

The code in < > brackets appearing in this column indicates the level of interchangeability between the indicated part and the former one. For the definition of the Codes, refer to "INTERCHANGEABILITY CODE LIST" shown in the lower corner of each fiche (frame No. N1).

⑩ NEW PART NUMBER'S SIGN

An asterisk (*) appearing in the "Part Number" column indicates that the affected Part Number has been newly added since the last edition.

⑪ VIN (CHASSIS No.)

VIN (Vehicle Identification Number) is shown in this column if necessary, to identify the vehicles applicable to the affected part. For further details, refer to "HOW TO INTERPRET THE VIN (CHASSIS No.)" located in frame No. H16 of this fiche.

HOW TO INTERPRET THE VIN (CHASSIS No.)

VEHICLE IDENTIFICATION SYSTEM FOR MAZDA RX-7 SERIES (1981-)

Vehicle Identification Number (VIN) for RX-7 (1981 and later year models) consists of World Manufacturer Identifier, Vehicle Description Section (VDS), Check Digit, Model Year Code and Production Serial Number, which is sequentially numbered within each VDS.

Shown below as an example is the VIN for Mazda RX-7 (1981 model).

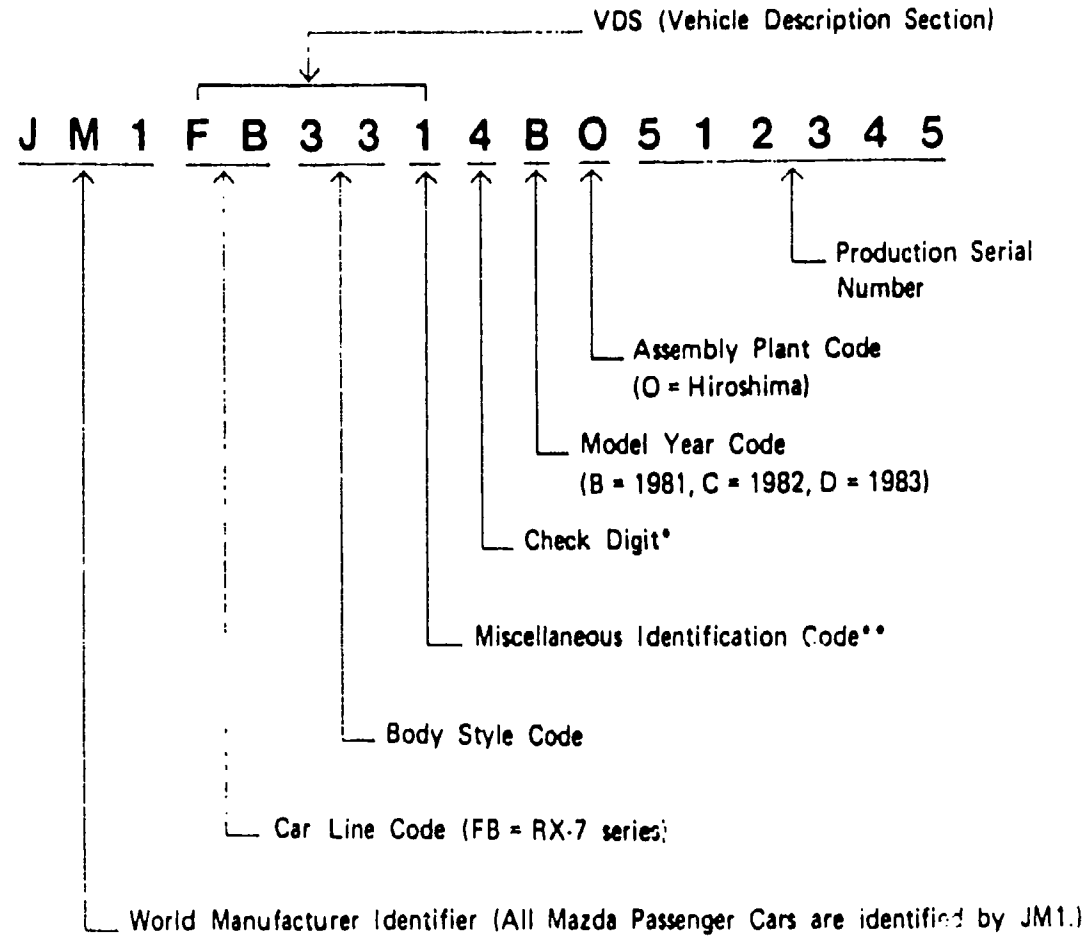

* Check Digit is included as a VIN security feature to permit law enforcement verification of the authenticity of a suspected illegal VIN plate. This single digit number is determined, based upon a complex mathematical formula which is applied to each vehicle's VIN number.

** Miscellaneous Identification Code identifies major components such as engine, brake system, cab type, etc. However, if all models of the same car line use the same such components, this code is indicated as a numeric character "1" only.

VIN PRESENTATION ON THE PARTS CATALOG

VIN does NOT ALWAYS APPEAR. No "VIN" indicated denotes that a Part is applicable to the affected model from the FIRST PRODUCTION and ON (up to now).

If the information in the "VIN" column appeared as the example below:

6230A-1 BACK DOOR MECHANISMS (HATCHBACK)

D-CODE (Key No.)	PART NAME	PART No.	Qty.	MODEL/DESCRIPTION	VIN (Chassis No.)
62210A	HINGE, BACK DOOR	8531-62-210B	2	1000 1300	FA4PS... 500001 -522626 FA4TS... 500001 -688439
		8531-62-210D	2		FA4PS... 522627- FA4TS... 688440- FA4US... 500001-
62310	LOCK, BACK DOOR	8531-62-310B	2		

... the correct interpretation of the above would be:

- ① Part No. 8531-62-210B is applicable to Model 1000 from VIN FA4PS-500001 thru FA4PS-522626 and Model 1300 from VIN FA4TS-500001 thru FA4TS-688439 for the Hatchback respectively.
- ② Part No. 8531-62-210D is applicable to Model 1000 from VIN FA4PS-522627 and on, Model 1300 from VIN FA4TS-688440 and on, and Model 1400 from VIN FA4US-500001 (the first production) and on for the Hatchback respectively.
- ③ Part No. 8531-62-310B is applicable to ALL MODELS (1000, 1300 and 1400) of the Hatchback series from the FIRST PRODUCTION and ON (up to now).

HOW TO INTERPRET THE MODEL APPLICATION

Model Application does NOT ALWAYS APPEAR. No "Model Application" indicated denotes that a Part is applicable to ALL MODELS covered by the affected page.

If the information in the "MODEL/DESCRIPTION" column appeared as the example below:

4000A-1 EX. SYSTEM (HATCHBACK) 

D-CODE (Key No.)	PART NAME	PART No.	QTY	MODEL/DESCRIPTION	VIN (Chassis No.)
40061	HANGER, SILENCER	3874-40-060	1	①	
40081	BRACKET	3952-40-080A	1	CAL. } ②	
		8021-40-080C	1	FED. } ③	

... the correct interpretation of the above would be:

- ① Part No. 3874-40-060 is applicable to All of Hatchbacks.
- ② Part No. 3952-40-080A is applicable to the Hatchbacks of CAL. applications.
- ③ Part No. 8021-40-080C is applicable to All Hatchbacks for FED. applications.

CAL. = California

FED. = Federal

MAZDA PART NUMBERING SYSTEM

Mazda Part Numbers are generally classified into three categories:
General Parts, Standard Parts and Special Tools.

MAZDA GENERAL PARTS

The Part Number basically consists of nine or ten digits. The 10th digit (if applicable) denotes modification of the part. It has twelve digits when a color code consisting of two digits is required.

EXAMPLE

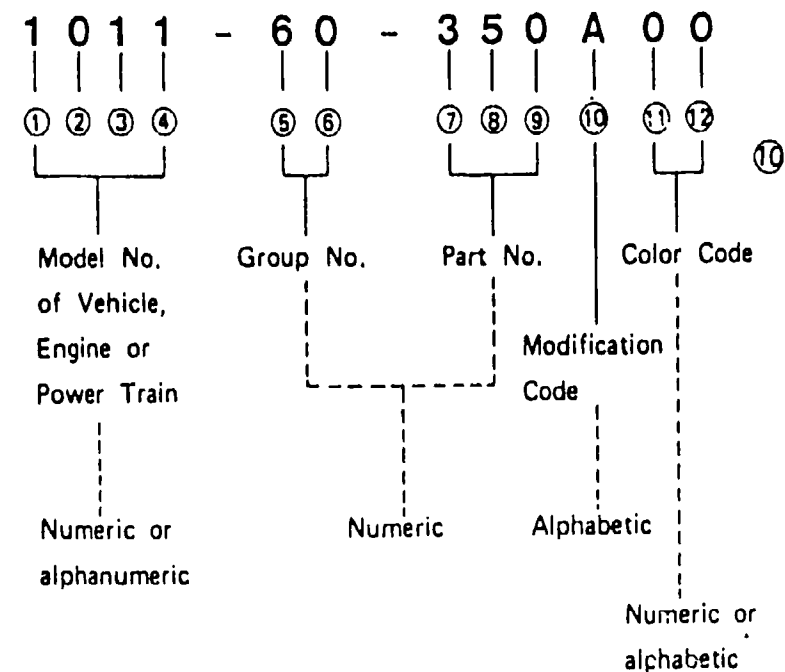

(Note)

If a color code was required but not modification code, the 10th digit would be blank and the color code would follow, e.g.,

1011-60-350_00

blank

MAZDA STANDARD PARTS

Those Parts which are standardized in form and dimension such as Bolts, Nuts, Washers, Hoses, Disc Wheels, etc. are called Mazda Standard Parts.

All the Mazda Standard Parts are identified by a Part Number starting with "9". The numbering structure of Standard Parts varies depending upon the kind of parts.

The following is just one example of Standard Part Numbers. For further details and examples, refer to the wall chart, "LIST OF STANDARD PARTS".

EXAMPLE

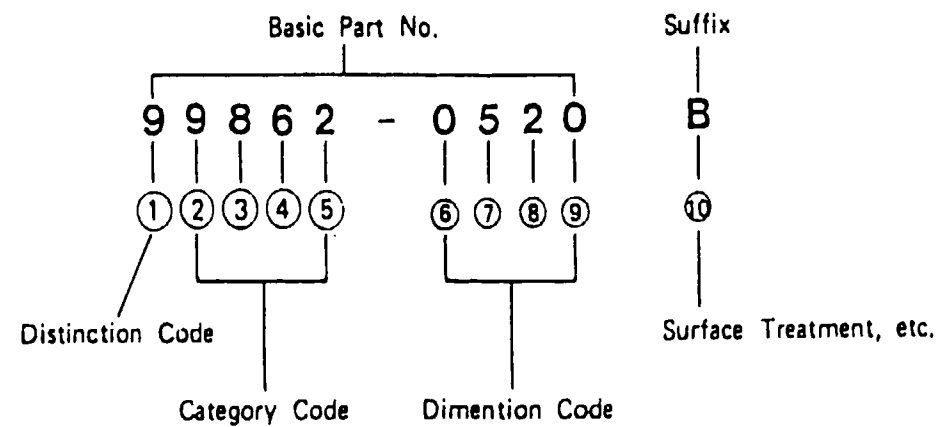

MAZDA SPECIAL TOOLS

In order to repair Mazda Vehicles, certain equipment is required. Those are called Mazda Special Tools.

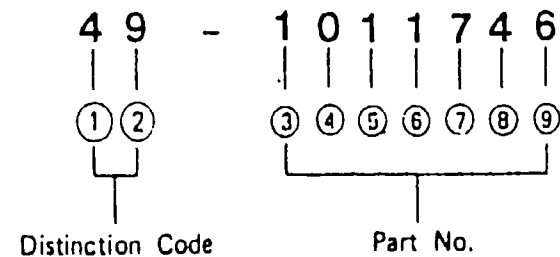

EXAMPLE



[Note]

As Mazda Special Tools are not shown in the Parts Catalog, refer to "LIST OF SPECIAL TOOLS & APPLYING MODELS" as for further details.

INTERCHANGEABILITY CODE LIST

Code	Definition	
AN	↔ (Both Ways)	A new part and the former part are fully interchangeable.
A	→ (One Way)	A new part can be used in place of the former part, but the former part cannot be used in place of a new part.
C	Plus 	A new part with some additional part(s) can be used in place of the former part.
G	Plus 	Some modification work is required to use a new part in place of the former part.
S	← (One Way Backward)	The former part can be used in place of a new part, but a new part cannot be used in place of the former part.

ABBREVIATION LIST

ABBREV.	MAY REPLACE	ABRREV.	MAY REPLACE
1ST	First	CAL.	California
2ND	Second	CASS.	Cassette
3RD	Third	CAT.	Category
4TH	Fourth	Cd	Coefficient Of Drag
4 SPD	Four Speed	CD	Compact Disk
4WS	Four Wheel Steering	C.G.R.	Constant Gear Ratio
4WD, 4X4	Four Wheel Drive	CHG.	Change
5TH	Fifth	CHK.	Check
5 SPD	Five Speed	CHMBR	Chamber
		CHN.	Chain
AA.	Anti Afterburn	CIGAR.	Cigarette
A.A.S.	Auto Adjusting Suspension	CI	Coefficient Of Lift
ABS	Anti Lock Braking System	CLPR	Caliper
A/C	Air Conditioning	CNVTR.	Converter
A.C.C.	Automatic Cruise Control	COMB.	Combination
ACCEL.	Accelerator	COND.	Condenser
A.C.V.	Air Control Valve	COMP.	Compressor
A.E.	Acoustical Equalizer	CONV.	Convertible
ALUM	Aluminum	C/P	Cab Plus
ALL	Automatic Load Leveling	C.S.D.	Cold Start Device
ALT.	Alternator	CSTG.	Coasting
AMP.	Amplifier	CTR.	Center
ANT.	Antenna	CTRL.	Control
APR.	April	CV	Constant Velocity
ASSY.	Assembly	CVR.	Cover
A/T	Automatic Transmission	CYL.	Cylinder
AUG.	August		
AUTO.	Automatic	DASH.	Dashboard
		Db	Decibels
BAL.	Balance	DEC.	December
BELT.	Beltline	DEF.	Defroster
BFGR	B. F. Goodrich	DIAPH	Diaphragm
BRDG	Bridgestone	DIFF.	Differential
BRG.	Bearing	DNL P	Dunlop
BRKT.	Bracket	DOHC	Double Overhead
BRN.	Brown		Came' aft
BLK.	Black	DSL.	Diesel
BLU.	Blue	DTSS	Dynamic Tracking Suspension System
BMPR.	Bumper		Deluxe
B.S.V.	Bleed Solenoid Valve	DX	
BULL.	Bulletin	ECAT	Electronically Controlled A/T
BW	Black Wall	EGI	Electronic Gas Injection
		EGR	Exhaust Gas Recirculation

ABBREVIATION LIST

ABBREV.	MAY REPLACE	ABBREV.	MAY REPLACE
ELEC.	Electric	INN.	Inner
ENG.	Engine	INT.	Interior
ETR	Electronically Tuned Radio	INTMT.	Intermittent
		INJ.	Injector, Injected
EXC.	Except	I.R.S.	Independent Rear Suspension
EXH.	Exhaust		
EXT.	Extension	JAN.	January
EQ	Equalizer	JUL.	July
		JUN.	June
FEB.	February		
FED.	Federal	KG	Kilogram
F.I.	Fuel Injection	KM	Kilometer
FLEX	Flexible	KW	Kilowatt
F/LID	Fuel Lid		
FRT.	Front	(L), LT	Left
FRST	Firestone	L=	Length
FSTNR.	Fastener	LCD	Liquid Crystal Display
		L/B	Long Bed
G	Gram	LH	Left Hand
GAS.	Gasoline	LPG	Liquid Petroleum Gas
GDYR	Goodyear	L.S.D.	Limited Slip Differential
GEN.	General		
GOV.	Governor	LWR	Lower
GRN.	Green	LX	Luxury
GRY.	Gray		
GSKT.	Gasket	M	Metallic
		MAR.	Merch
H.A.C.	High Altitude Compensator	MC	Mica
HARN.	Harness	MCHN	Michelin
H/B	Hatchback	MLDG.	Moulding, Mould
HD.	Head	MM	Millimeter
H/DUTY	Heavy Duty	MNFLD.	Manifold
HDWE.	Hardware	MPX	Multiplex
Hi. ALT.	High Altitude	MSTR.	Master
HSG.	House, Housing	M/T	Manual Transmission
HTR.	Heater	MTG.	Mounting
		MTR	Manually Tuned Radio
IC	Integrated Circuit		
ID	Inside Diameter	N=	Number Of Teeth
IGN.	Ignition	N/A	Not Available
ILLUM.	Illumination, Illuminated	N/B	Notchback
INCL	Includes	NO.	Number
IND	Indicator	NORM.	Normal
INFO.	Information	NOV.	November
INST.	Instrument		

ABBREVIATION LIST

ABBREV.	MAY REPLACE	ABBREV.	MAY REPLACE
OCT.	October	SPEC.	Specification
OD	Outer Diameter	SPEEDO.	Speedometer
O/DRIVE	Overdrive	SPG.	Spring
OHC	Overhead Camshaft	SPKR.	Speaker
OPT.	Optional	SPRKT.	Sprocket
O.S.	Oversize	SRS	Supplemental Restraint System
OUT.	Outer	STAB.	Stabilizer
PANSC	Panasonic	STD.	Standard
PARK.	Parking	STRG.	Steering
PB	Parking Brake	S/ROOF	Sunroof
PCV	Positive Crankcase Ventilation	SUSP.	Suspension
PIN.	Pinion	S/W	Station Wagon
PKG	Package	SW.	Switch
PLR	Pillar	SYNC.	Synchronizer
PROD.	Production	T=	Thickness
P/S	Power Steering	TEMP.	Temperature
P/TRIM	Pillar Trim	THERMO.	Thermostat
PTH	Phillips Truss Head	TMG.	Timing
PWR.	Power	T/MISSION	Transmission
QTR.	Quarter	TRK.	Truck
QTY.	Quantity	T/LID	Trunk Lid
(R), RT	Right	T/S	Touring Sedan
RH	Right Hand	TTL	Twin Trapezoidal Links
RAD.	Radiator	TURBO	Turbocharged
REINF.	Reinforcement	UP.	Upper
REG.	Regular	U.S.	Undersize
REGUL.	Regulator	VAC.	Vacuum
REL.	Release	V.G.R.	Variable Gear Ratio
REM.	Remote	VPV	Variable Port Valve
RET.	Return	VNL.	Vinyl
REV.	Reverse	W=	Width
RR.	Rear	W/	With
RWL	Raised White Letters	W/P	Water Pump
S/B	Short Bed	WGN.	Wagon
S/ROD	Shift Rod	WHL.	Wheel
S/S	Supercession	W/O	Without
SDN.	Sedan	WHT.	White
SEP.	September	W/SHIELD	Wind Shield, Screen
SERV.	Service	WTR.	Water
SLND.	Solenoid	W/W	White Walls
SOHC	Single Overhead		

mazda
1981-83 RX-7 ACCESSORIES

AERO

0000-86-2200 - 1979-85, Lip Spoiler

AIR CONDITIONER

Refer to Accy. Bulletin XA-1 for Air Conditioner information.

ARM REST

Refer to Accy. Bulletin XN-1 for replacement parts.

BATTERY

0000-80-124K - 1979-83, ALL
Refer to Accy. Bulletin XG-4 for Battery information.

BLOCK HEATER

0000-88-6600 - ALL, Rotary Engine
Refer to Accy. Bulletin XG-5 for installation information.

CIGARETTE LIGHTERS

0000-88-209 -16 - 1981-82, All

DOOR EDGE GUARDS

0000-88-3199-BK - ALL, Black Universal Type

FRONT MASK

0000-88-0581-AS - 1981-83, W/O Air Dam

PAINT

Refer to Accy. Bulletin XE-2 for Touch-Up Paint information.

STEREO EQUIPMENT

Refer to Accy. Bulletins XS-1, XS-2, and XS-3 for Audio information.

SUNROOF

0000-86-2600 - 1980-85, Moonroof
0000-86-2600-KT - 1980-85, Left & Right Hinge
0000-86-2600-CP - 1980-85, Cap Nut Set
8346-62-885 - 1980-85, Slide Hook Latch

TIRES

Refer to Accy. Bulletins XE-1 for Tire information.

SECTION INDEX -- BODY

STARTING LOCATION	SECT. NO.	SECTION NAME	STARTING LOCATION	SECT. NO.	SECTION NAME	STARTING LOCATION	SECT. NO.	SECTION NAME
2 - C 3	0900A	KEY SETS	2 - C 8	6132AC	CONDENSER PACKAGE ('83 MODEL)	2 - H11	6870A	SERVICE TOOLS
2 - D 3	5000A	FRONT BUMPER	2 - E 8	6142A	COMPRESSOR MOUNTING KIT, COMPRESSOR/CLUTCH ASSEMBLY & REPAIR PARTS ('81 MODEL)	2 - I11	6900A	VISOR, ASSIST HANDLE & MIRRORS
2 - E 3	5005A	EXHAUSTOR GRILLE	2 - F 8	6142AB	COMPRESSOR MOUNTING KIT, COMPRESSOR/CLUTCH ASSEMBLY & REPAIR PARTS ('82 MODEL)	2 - L11	6930A	CAUTION PLATES
2 - F 3	5010A	REAR BUMPER	2 - G 8	6142AC	COMPRESSOR MOUNTING KIT, COMPRESSOR/CLUTCH ASSEMBLY & REPAIR PARTS ('83 MODEL)			
2 - G 3	5030A	WINDOW MOULDINGS	2 - H 8	6152A	EVAPORATOR PACKAGE ('81 MODEL)			
2 - H 3	5040A	BODY MOULDINGS	2 - I 8	6152AB	EVAPORATOR PACKAGE ('82 MODEL)			
2 - I 3	5060A	SIDE PROTECTORS	2 - J 8	6152AC	EVAPORATOR PACKAGE ('83 MODEL)			
2 - J 3	5100A	HEAD LAMPS	2 - K 8	6230A	BACK DOOR MECHANISM			
2 - K 3	5103A	HEAD LAMP RETRACTORS	2 - L 8	6300A	WINDOW GLASSES			
2 - L 3	5105A	FRONT COMBINATION & SIDE TURN LAMPS	2 - M 8	6330A	SUNROOF (GSI)			
2 - M 3	5110A	REAR COMBINATION LAMPS	2 - N 8	6600A	SWITCH & RELAY (ENGINE & TRANSMISSION)			
2 - N 3	5120A	LICENSE & REAR SIDE TURN LAMPS	2 - C 9	6610A	DASHBOARD SWITCHES (MANUAL OPERATING)			
2 - C 4	5125A	INTERIOR LAMPS (GS & GSI)	2 - D 9	6611A	COMBINATION SWITCH			
2 - D 4	5170A	ORNAMENTS	2 - E 9	6615A	POWER WINDOW SWITCH			
2 - E 4	5180A	COWL & EXTRACTOR GRILLES	2 - F 9	6620A	DOOR, PARKING LAMP & KICK DOWN SWITCH			
2 - F 4	5230A	HOOD	2 - G 9	6630A	RELAY (BODY)			
2 - G 4	5310A	BODY PANELS (FRONT)	2 - H 9	6635A	HORN			
2 - I 4	5340A	BODY PANELS (SIDE & ROOF)	2 - I 9	6640A	AUTO CRUISE CONTROL			
2 - J 4	5360A	BODY PANELS (FLOOR)	2 - J 9	6680A	AUDIO SYSTEM			
2 - K 4	5370A	FLOOR ATTACHMENTS	2 - M 9	6700A	WIRE HARNESS (FRONT & REAR)			
2 - L 4	5500A	DASHBOARD EQUIPMENT	2 - N 9	6701A	WIRE HARNESS (ENGINE & TRANSMISSION)			
2 - N 4	5540A	METERS	2 - C10	6702A	WIRE HARNESS (DASHBOARD)			
2 - C 5	5560A	DASHBOARD & RELATED	2 - D10	6703A	WIRE HARNESS (DOOR, FLOOR & CEILING)			
2 - E 5	5570A	CONSOLE	2 - E10	6704A	WIRE HARNESS CLAMPS			
2 - G 5	5580A	VENTILATOR	2 - F10	6720A	WINDSHIELD WASHER			
2 - H 5	5700A	SEATS ('81 & '82) MODELS	2 - G10	6730A	WINDSHIELD WIPER			
2 - C 6	5700AA	SEATS ('83 MODEL)	2 - H10	6740A	WIPER MOTOR (COMPONENTS ONLY)			
2 - H 6	5790A	SEAT BELTS	2 - I10	6750A	REAR WINDOW WIPER & WASHER			
2 - J 6	5800A	FRONT DOOR	2 - J10	6760A	REAR WINDOW WIPER MOTOR (COMPONENTS ONLY)			
2 - K 6	5830A	FRONT DOOR MECHANISM	2 - K10	6800A	CEILING TRIM			
2 - C 7	5840A	FRONT DOOR TRIM & RELATED PARTS	2 - C11	6840A	TRIM & SCUFF PLATE			
2 - F 7	6100A	HEATER	2 - F11	6860A	FLOOR MATS & PADS			
2 - G 7	6110A	HEATER UNIT						
2 - H 7	6115A	HEATER CONTROLS						
2 - I 7	6120A	HEATER BLOWER						
2 - J 7	6132A	CONDENSER PACKAGE ('81 MODEL)						
2 - L 7	6132AB	CONDENSER PACKAGE ('82 MODEL)						

0900A-1 KEY SETS

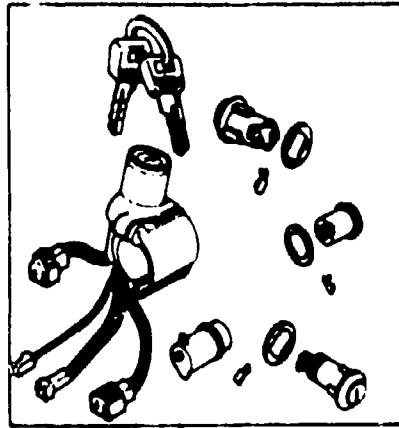

09010

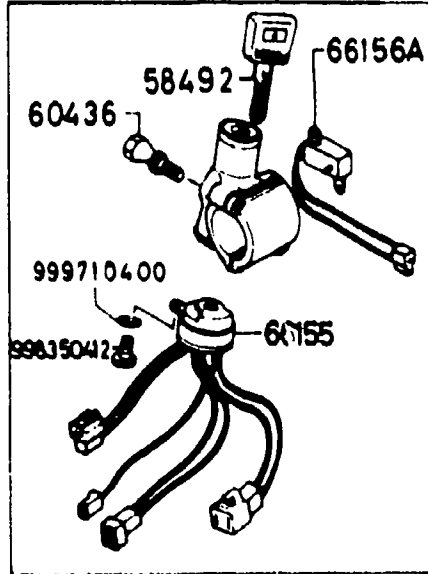

75990
A

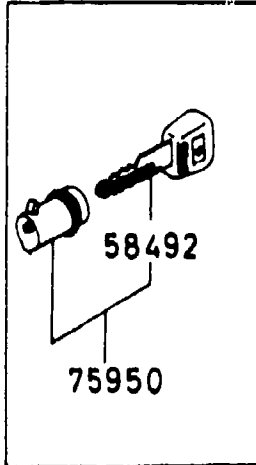

B

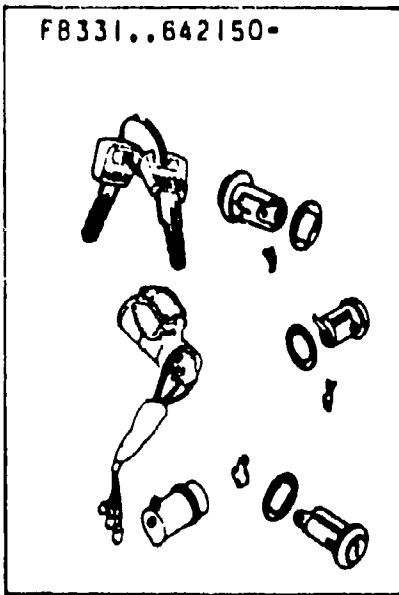

75158

58492



KEY, BLANK

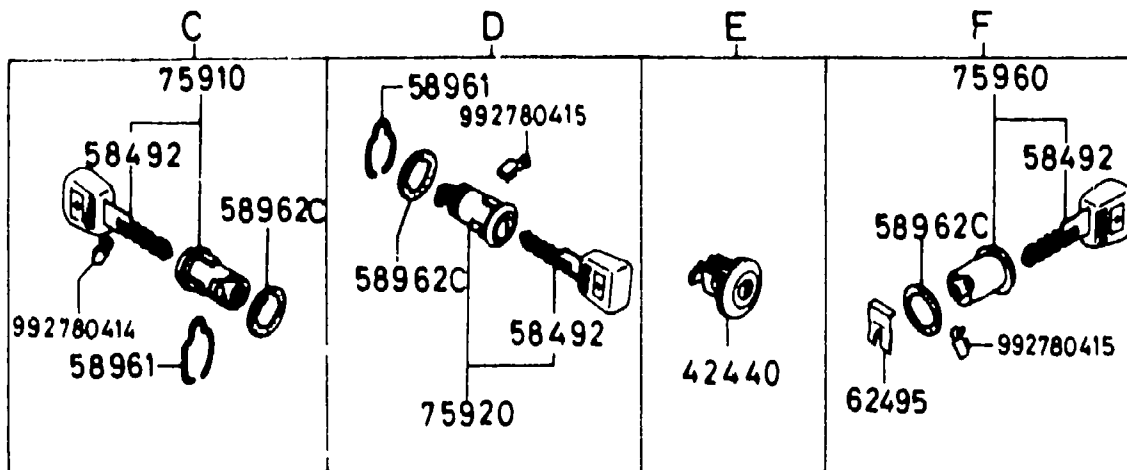
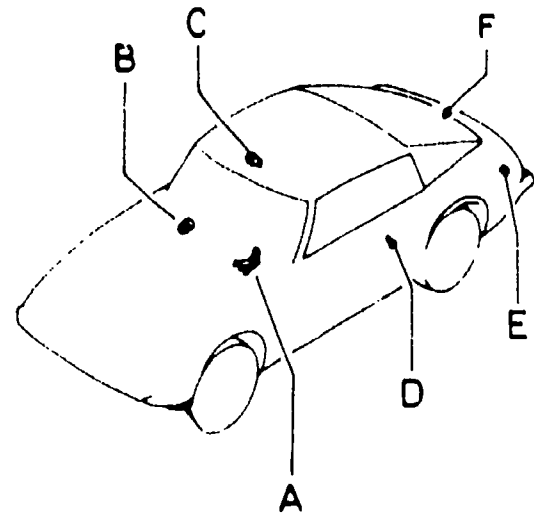
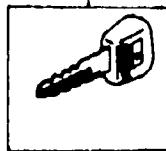

ITEM NO.	D-CODE	DESCRIPTION	PART NO.	QTY	MODEL/DESCRIPTION	REMARKS
09 010		KEY SET	FA01-09-010B	1		
42 440		LOCK, FILLER LID	FA01-42-440A	1		
58 492		KEY, PRIMARY	8208-75-901	2	'81 & '82 MODELS	
		REFER TO PARTS BULL. NO. A-2-4 FOR MORE INFO.				
58 961		FASTENER, KEY CYLINDER	0223-58-961	2		
58 962C		GASKET, KEY CYLINDER	0223-58-962	3		
60 436		BOLT, SET	8218-66-143	2	'81 & '82 MODELS	FB331 ..500001-700000
			H043-66-154	2	'83 MODEL	
62 495		RETAINER, LOCK CYLINDER	0223-58-961	1	'81 MODEL	FB331 ..500001-501577
			B001-62-495	1		FB331 ..501578-
66 155		SWITCH, IGNITION	BA14-66-151A	1	'81 & '82 MODELS	FB331 ..500001-642149
			BA24-66-155A	1	'82 & '83 MODELS	FB331 ..642150-
66 156A		SWITCH, BUZZER	BA14-66-156	1	'81 & '82 MODELS	FB331 ..500001-700000
75 158		KEY, BLANK	8208-75-901	1	'81 & '82 MODELS	
			HA40-76-201	1	'83 MODEL	
75 910		KEY SUB SET (R), DOOR	FA01-76-210	1	'81 & '82 MODELS	
			FA43-76-210	1	'83 MODEL	
75 920		KEY SUB SET (L), DOOR	FA01-76-220	1	'81 & '82 MODELS	
			FA43-76-220	1	'83 MODEL	
75 950		KEY SUB SET, GLOVE	FA01-76-250	1	'81 & '82 MODELS	
			FA43-76-250	1	'83 MODEL	
75 960		KEY SUB SET, BACK DOOR	FA01-76-260	1	'81 & '82 MODELS	
			FA43-76-230	1	'83 MODEL	
75 990		KEY SUB SET, STEERING	GA02-76-290	1	'81 & '82 MODELS	
			BE32-76-290A	1	'83 MODEL	

5000A-1 FRONT BUMPER

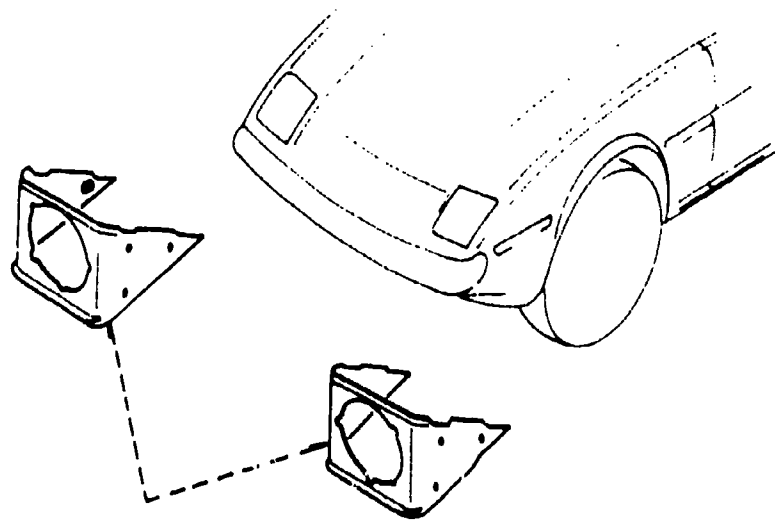

REFER TO SECT.NO.5005A

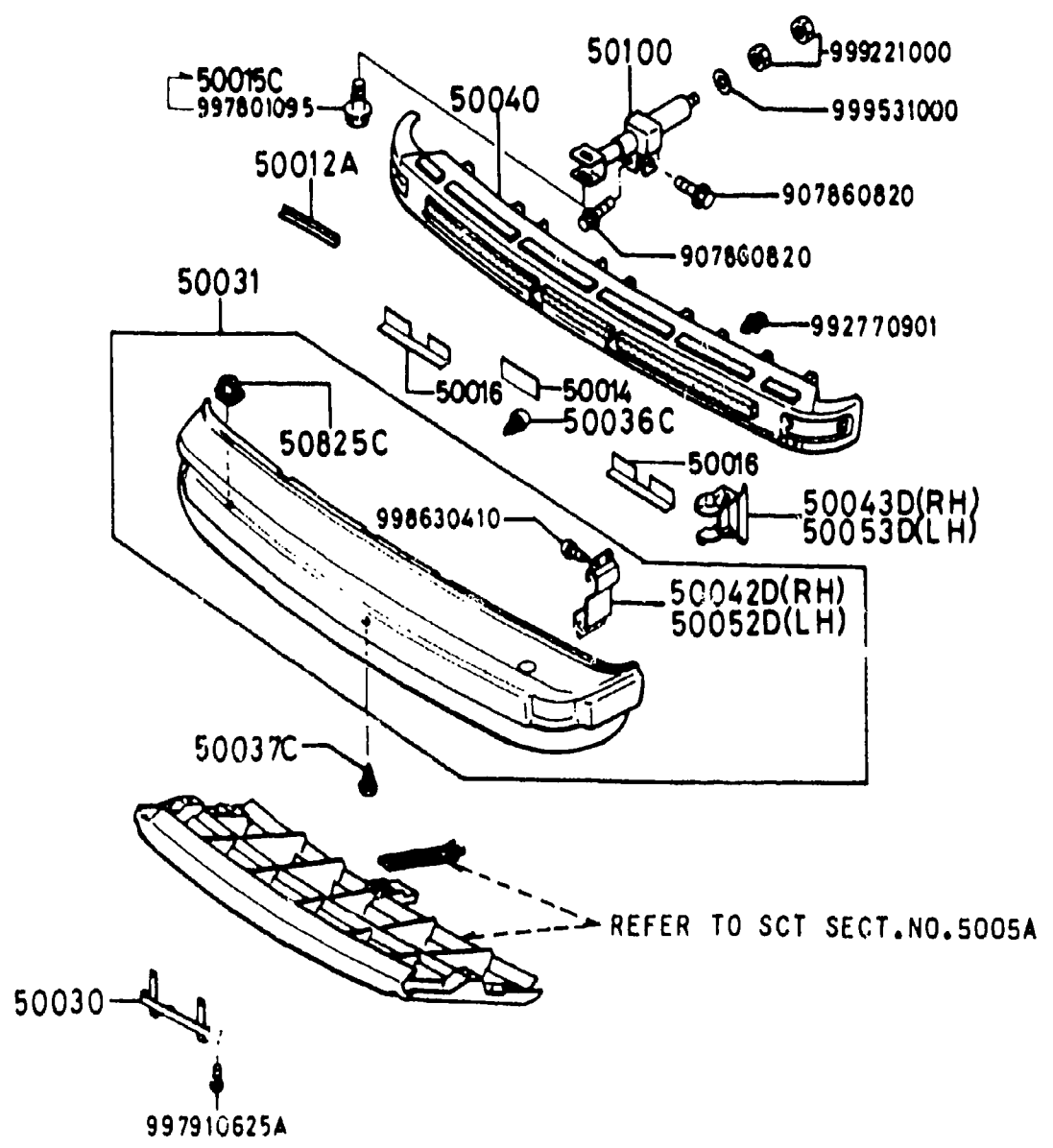

ITEM NO.	D-CODE	DESCRIPTION	PART NO.	QTY	MODEL/DESCRIPTION	REMARKS
50 012A		PROTECTOR	FA01-50-012	5	'81 MODEL	FB331 ..500001-500762
				1		FB331 ..500763-
50 014		PROTECTOR	FA01-50-014	2		
50 015C		BOLT	FA01-50-015	2		FB331 ..507335-
50 016		PROTECTOR	FA01-50-016	2		FB331 ..500763-
50 030		HOLDER, LICENSE PLATE	FA01-50-180	1		
50 031		BUMPER, FRONT	FA01-50-030A	1		
50 036C		FASTENER	FA01-50-036	9		
50 037C		FASTENER	FA01-50-037	5		
50 040		REINFORCEMENT, BUMPER	FA01-50-150A	1		
50 042D		SLIDE 'B' (R), BUMPER	FA01-50-042	1		
50 043D		SLIDE 'A' (R), BUMPER	FA01-50-040	1		
50 052D		SLIDE 'B' (L), BUMPER	FA01-50-052	1		
50 053D		SLIDE 'A' (L), BUMPER	FA01-50-050	1		
50 100		ABSORBER (R), SHOCK	FA01-50-070	1		
		ABSORBER (L), SHOCK	FA01-50-080	1		
50 825C		NUT, CLIP	8871-50-825	4		

5005A-1 RADIATOR GRILLE

ITEM NO.	D-CODE	DESCRIPTION	PART NO.	QTY	MODEL/DESCRIPTION	REMARKS
	50 711	GRILLE, RADIATOR	FA01-50-711A	1		
	50 715A	BRACKET, RADIATOR	8871-50-720	1		
	50 740	BEZEL (R), LAMP	8871-50-741	1		
	50 760	BEZEL (L), LAMP	8871-50-761	1		

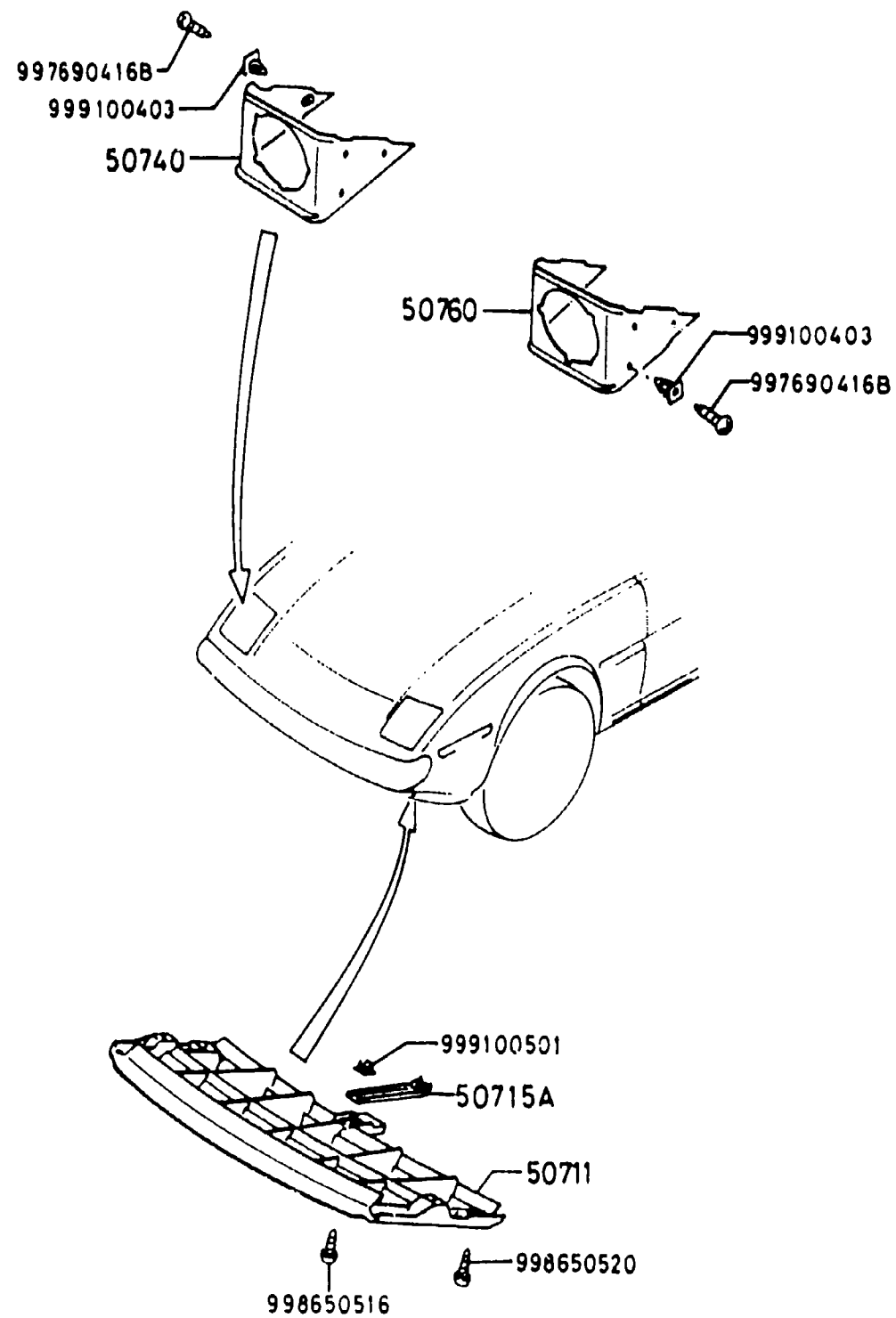

5010A-1 REAR BUMPER

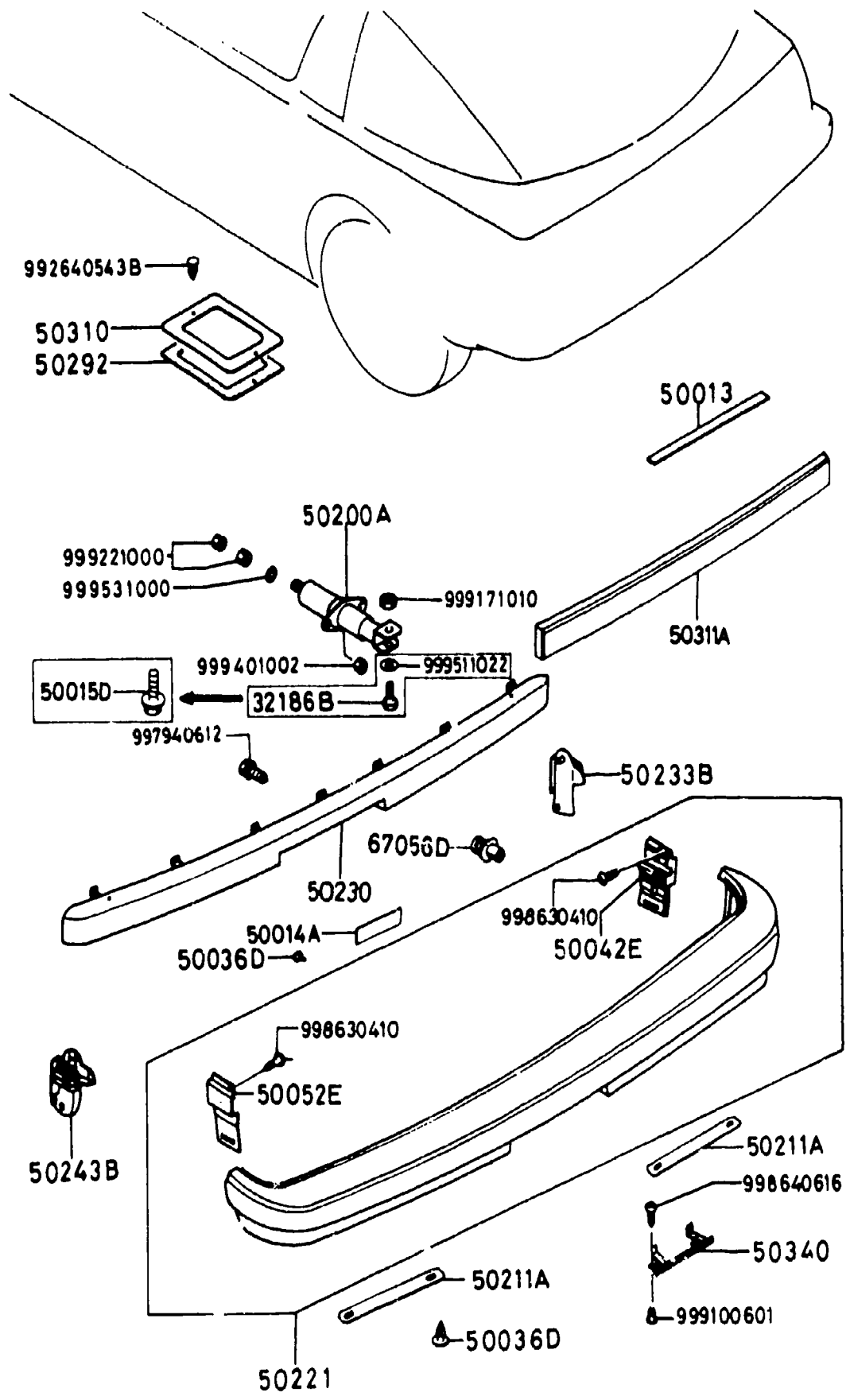

ITEM NO.	D-CODE	DESCRIPTION	PART NO.	QTY	MODEL/DESCRIPTION	REMARKS
	32 186B	BOLT	0603-32-186	2	'81 MODEL	FB331 ..50001-507334
	50 013	PROTECTOR	FA01-50-013	3		
	50 014A	PROTECTOR	FA01-50-014	2		
	50 015D	BOLT	FA01-50-015	2		
	50 036D	FASTENER	FA01-50-036	1		
	50 042E	SLIDE 'B' (R), BUMPER	FA01-50-232	1		
	50 052E	SLIDE 'B' (L), BUMPER	FA01-50-242	1		
	50 200A	ABSORBER, SHOCK-REAR	FA01-50-280A	2		
	50 211A	PLATE SET	FA01-50-211	4		
	50 221	BUMPER, REAR	FA01-50-220	1		
	50 230	REINFORCEMENT, BUMPER	FA01-50-330A	1		
	50 233B	SLIDE 'A' (R), BUMPER	FA01-50-230	1		
	50 243B	SLIDE 'A' (L), BUMPER	FA01-50-240	1		
	50 292	GASKET, HOLE COVER	8871-50-232	2		
	50 310	COVER, SERVICE HOLE	8871-50-231	2		
	50 311A	FILLER, REAR BUMPER	FA01-50-223	1		
	50 340	HOLDER, LICENSE PLATE	FA01-50-380	1		
	67 056D	RIVET	W023-67-056	7		

5030A-1 WINDOW MOULDINGS

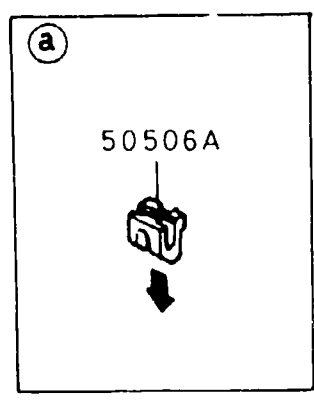
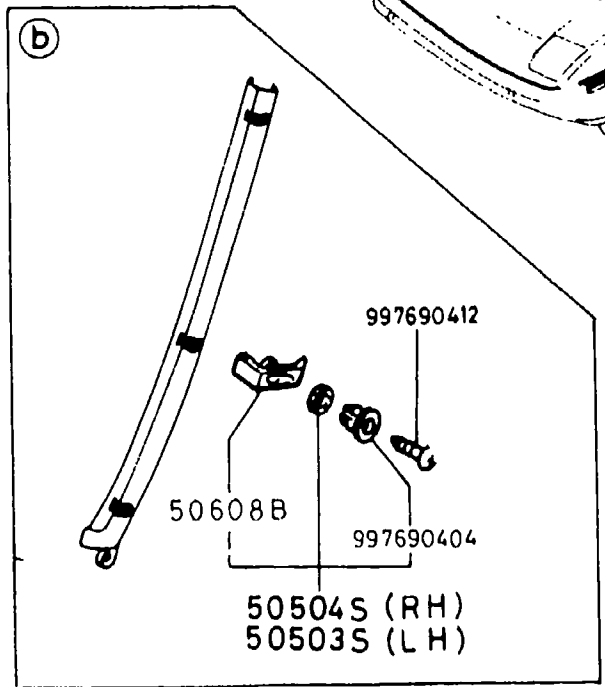
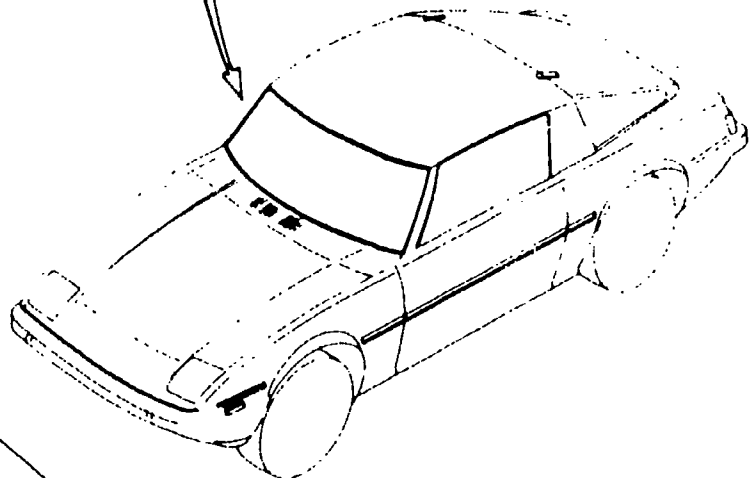
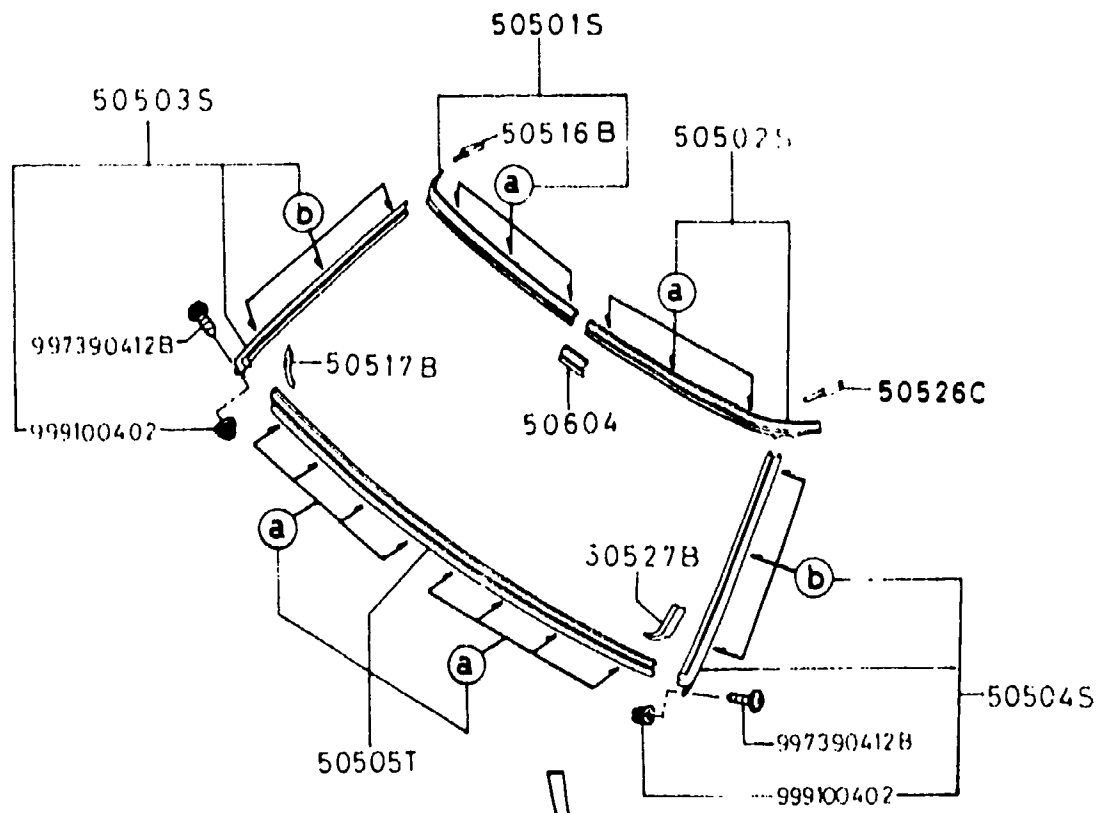

ITEM NO.	D-CODE	DESCRIPTION	PART NO.	QTY	MODEL/DESCRIPTION	REMARKS
50 501S		MOULDING SET (R), FRONT-UPPER	8871-99-741B	1		
50 502S		MOULDING SET (L), FRONT-UPPER	8871-99-742B	1		
50 503S		MOULDING SET (R), FRONT-SIDE	8871-99-743B	1		
50 504S		MOULDING SET (L), FRONT-SIDE	8871-99-744B	1		
50 505T		MOULDING SET, FRONT-LOWER	8871-99-745A	1		
50 506A		CLIP	1243-50-609	14		
50 516B		DUM 'A' (R)	8871-50-516	1		
50 517B		DUM 'B' (R)	8871-50-517	1		
50 526C		DUM 'A' (L)	8871-50-526	1		
50 527B		DUM 'B' (L)	8871-50-527	1		
50 604		JOINT, MOULDING-UPPER	8871-50-950B	1		
50 608B		FASTENER, W/SHIELD MLDG.-FRONT	8871-50-608	6		

5040A-1 BODY MOULDINGS

ITEM NO.	D-CODE	DESCRIPTION	PART NO.	QTY	MODEL/DESCRIPTION	REMARKS
	50 441	MOULDING (R), DRIP	8871-50-510C	1		
	50 451	MOULDING (L), DRIP	8871-50-520C	1		

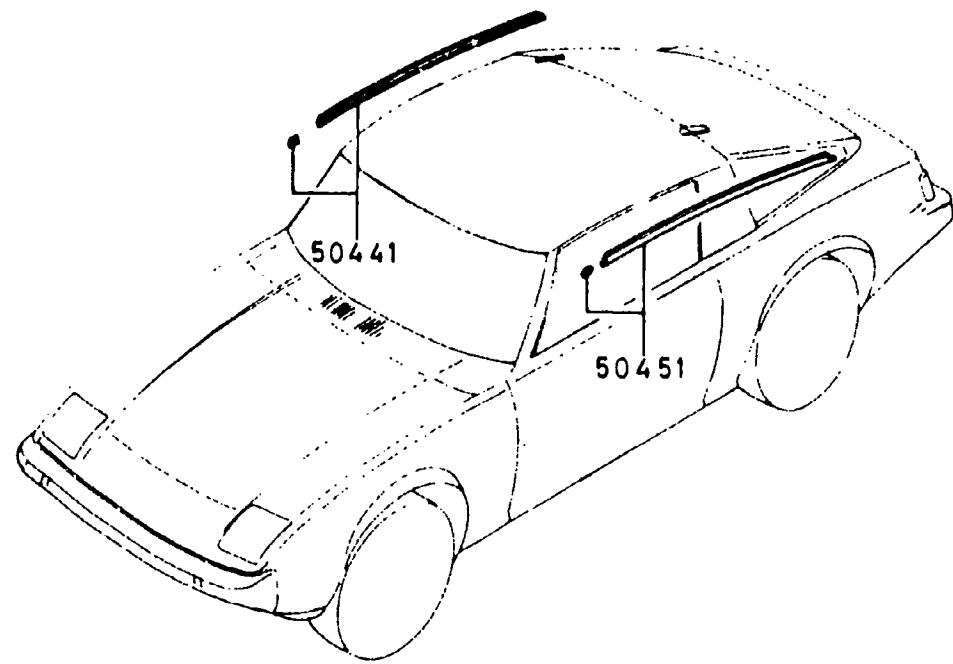

5060A-1 SIDE PROTECTORS

ITEM NO.	D-CODE	DESCRIPTION	PART NO.	QTY	MODEL/DESCRIPTION	REMARKS
	50 681D	PROTECTOR 'B' (R), SIDE	FA02-50-682	1		
	50 682A	PROTECTOR 'C' (R), SIDE	FA02-50-683	1		
	50 682B	PROTECTOR 'C' (L), SIDE	FA02-50-693	1		
	50 683D	PROTECTOR 'D' (R), SIDE	FA02-50-684	1		
	50 684D	PROTECTOR 'E' (R), SIDE	FA01-50-685	1		
	50 686D	PROTECTOR 'B' (L), SIDE	FA02-50-692	1		
	50 688D	PROTECTOR 'D' (L), SIDE	FA02-50-694	1		
	50 689D	PROTECTOR 'E' (L), SIDE	FA01-50-695	1		
	50 692D	PROTECTOR 'A' (R), SIDE	FA01-50-681	1		
	50 697D	PROTECTOR 'A' (L), SIDE	FA01-50-691	1		

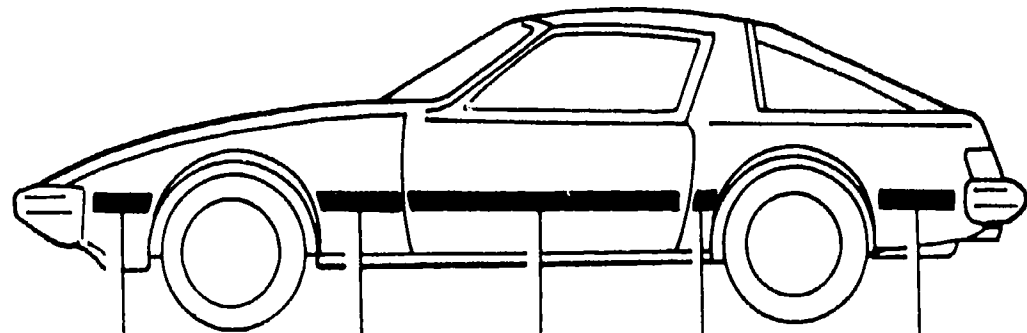

50697D	50686D	50682B	50688D	50689D (L.H.)
50692D	50681D	50682A	50683D	50684D (R.H.)

5100A-1 HEAD LAMPS

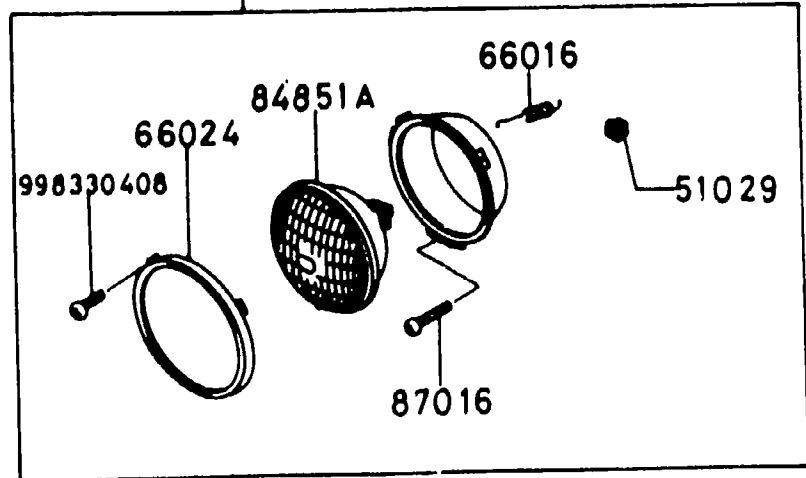
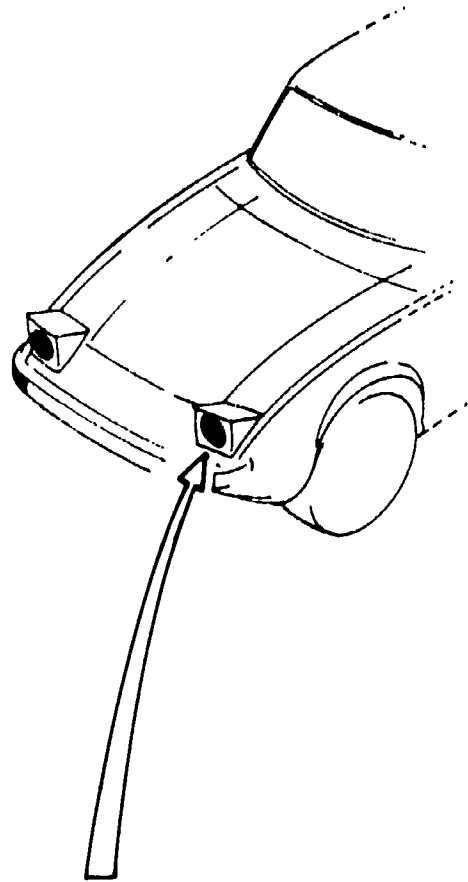

ITEM NO.	D-CODE	DESCRIPTION	PART NO.	QTY	MODEL/DESCRIPTION	REMARKS
51 029		GROMMET, SCREW	0483-66-061A	4		
51 030S		LAMP SET (R), HEAD	8871-89-661	1	(CONVENTIONAL) S MODEL	
			FA02-89-661	1	(HALOGEN) GS & GSL MODELS	
51 030T		LAMP SET (L), HEAD	FA02-89-666	1	(HALOGEN) GS & GSL MODELS	
			8871-89-666	1	(CONVENTIONAL) S MODEL	
66 016		SPRING, ADJUST	8871-51-021	2		
66 024		RING, RETAINING	8871-51-033	2		
84 851A		BEAM, SEALED	0000-11-6014	2	(CONVENTIONAL) S MODEL	
			0000-11-6024-HL	2	(HALOGEN) GS & GSL MODELS	
87 016		SCREW, ADJUST	3958-51-021	4		

5103A-1 HEAD LAMP RETRACTORS

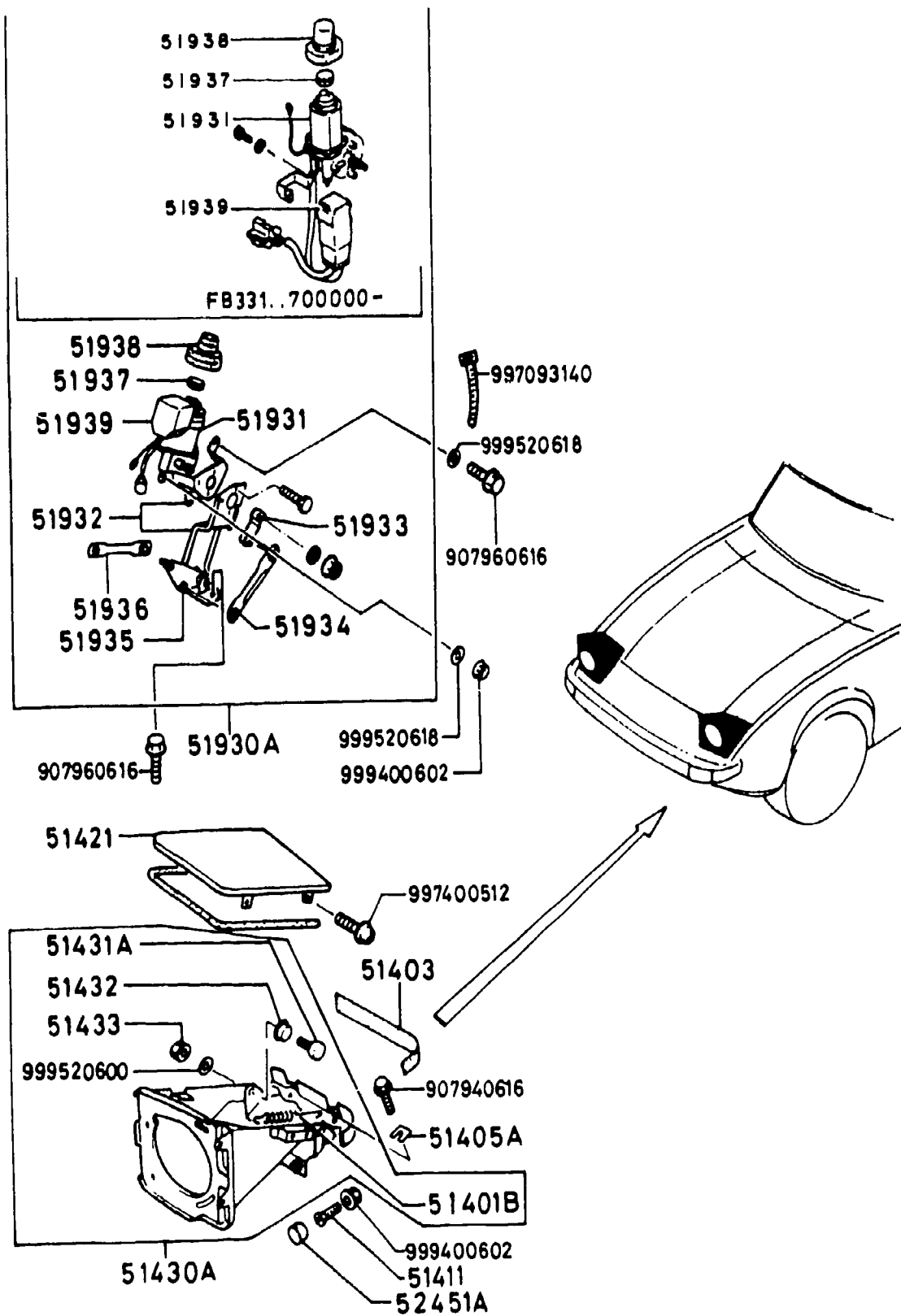

ITEM NO.	D-CODE	DESCRIPTION	PART NO.	QTY	MODEL/DESCRIPTION	REMARKS
	51 401B	SPRING, LID-LAMP	8871-51-401	2		
	51 403	PROTECTOR	8871-51-403	2		
	51 405A	SHIM, TILTING HINGE	8871-51-405	6		
	51 411	SCREW, STOPPER	8871-51-411	2		
	51 421	LID (R), LAMP	8871-51-421A	1		
		LID (L), LAMP	8871-51-621A	1		
	51 430A	HINGE (R), LID-LAMP	8871-51-430C	1		
		HINGE (L), LID-LAMP	8871-51-630C	1		
	51 431A	BOLT, HINGE	8871-51-431	4		
			H001-51-511	4	'83 MODEL	FB331 ..703771-
	51 432	BUSHING, HINGE BOLT	8871-51-432	4		
	51 433	NUT, HINGE	8871-51-433	4		
			9994-00-600	4	'83 MODEL	FB331 ..703771-
	51 930A	MOTOR & LINK (R)	FA01-51-930B	1		
		MOTOR & LINK (L)	FA01-51-940B	1		
	51 931	MOTOR (R)	FA01-51-931B	1		
		MOTOR (L)	FA01-51-941B	1		
	51 932	BRACKET (R)	8871-51-932	1		
		BRACKET (L)	8871-51-942	1		
	51 933	ROD, MOTOR	8871-51-933	2		
	51 934	ROD 'A'	8871-51-934	2		
	51 935	LEVER (R), LINK	8871-51-935	1		
		LEVER (L), LINK	8871-51-945	1		
	51 936	ROD 'B'	8871-51-936	2		
	51 937	KNOB	8871-51-937	2	'81 & '82 MODELS	FB331 ..500001-700000
			H001-51-667	2	'83 MODEL	
	51 938	BOOT	8871-51-938	2	'81 & '82 MODELS	FB331 ..500001-700000
			H001-51-666	1	'83 MODEL	
	51 939	RELAY	8871-51-939	2	'81 & '82 MODELS	FB331 ..500001-700000
			FA01-51-939	1	'83 MODEL	
	52 451A	RUBBER, CUSHION	0866-52-451	2		

5105A-1 FRONT COMBINATION & SIDE TURN LAMPS

ITEM NO.	D-CODE	DESCRIPTION	PART NO.	QTY	MODEL/DESCRIPTION	REMARKS
	51 060J	BULB	0000-11-1157	2	(A12V 27/8W)	
	51 060S	LAMP SET (R), FRONT COMB.	FA01-89-662	1		
	51 060T	LAMP SET (L), FRONT COMB.	FA01-89-667	1		
	51 062A	GASKET, FRONT COMB.	FA01-51-063	2		
	51 063	LENS (R), FRONT COMB.	FA01-51-061	1		
		LENS (L), FRONT COMB.	FA01-51-071	1		
	51 120J	BULB	0000-11-0194	2	(A12V 3.8W)	
	51 120S	LAMP SET (R), SIDE TURN	FA01-89-663	1		
	51 120T	LAMP SET (L), SIDE TURN	FA01-89-668	1		
	51 122	LENS (R), SIDE TURN	FA01-51-121	1		
		LENS (L), SIDE TURN	FA01-51-131	1		
	51 516	PROTECTOR, CORD	8545-51-516	2		

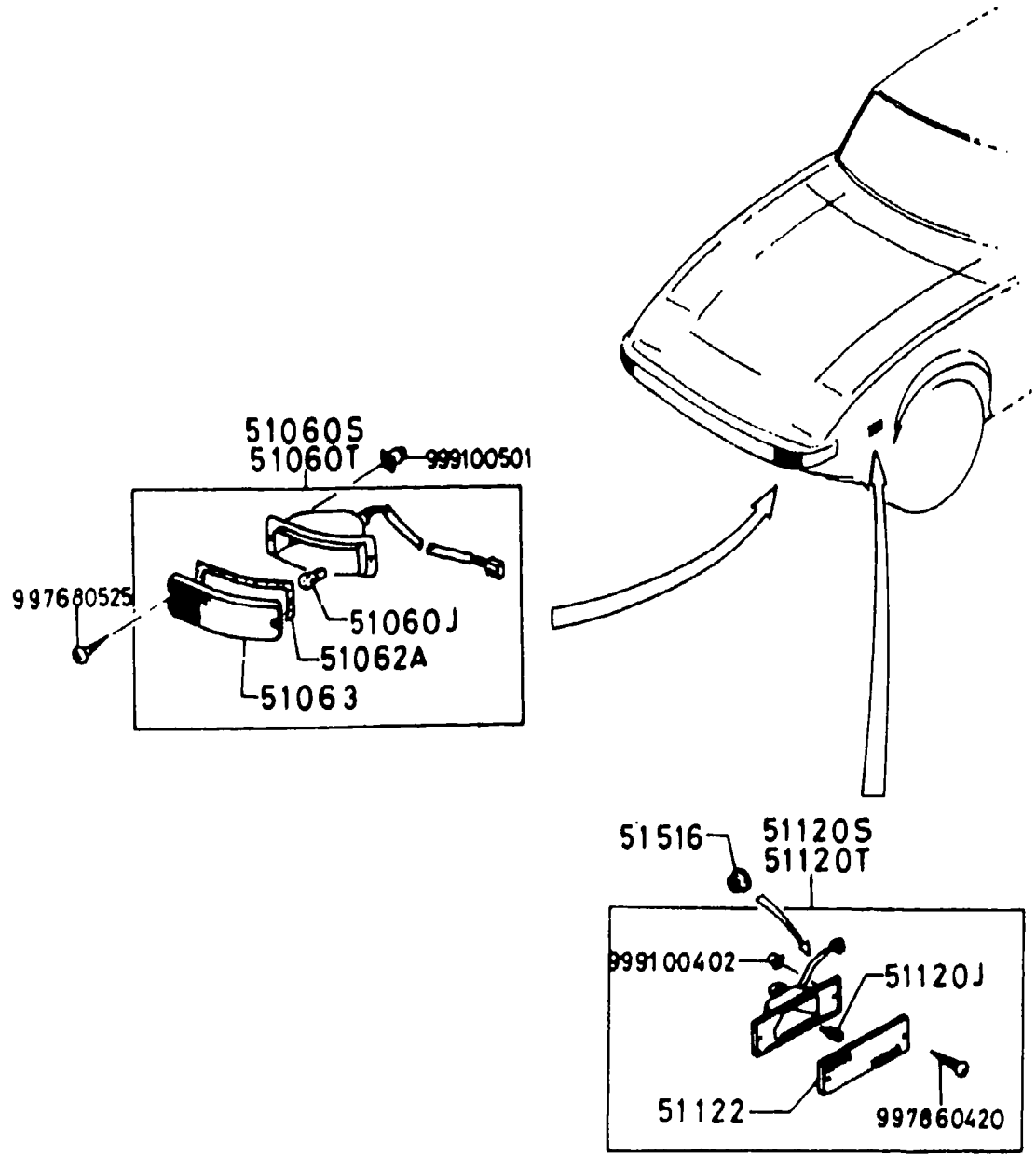

5110A-1 REAR COMBINATION LAMPS

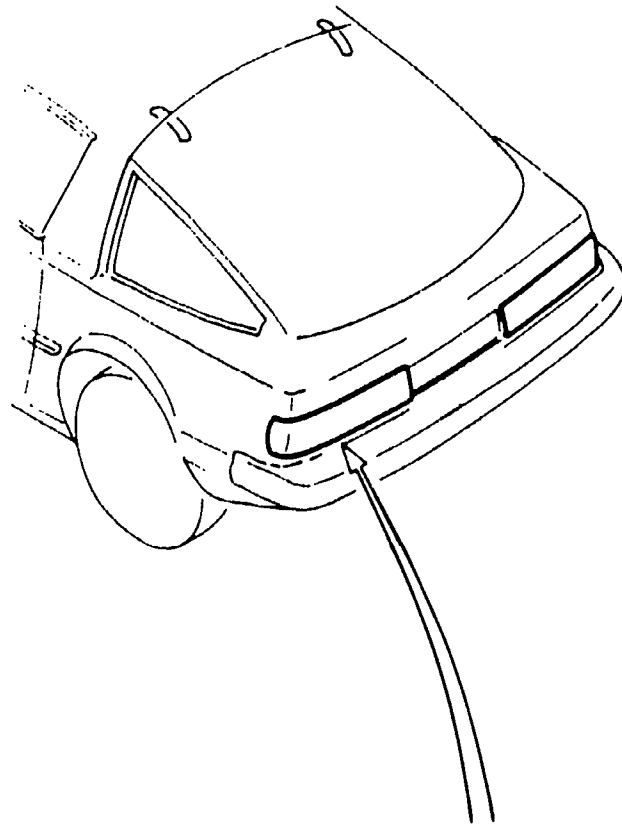

51150S(RH)
51150T(LH)

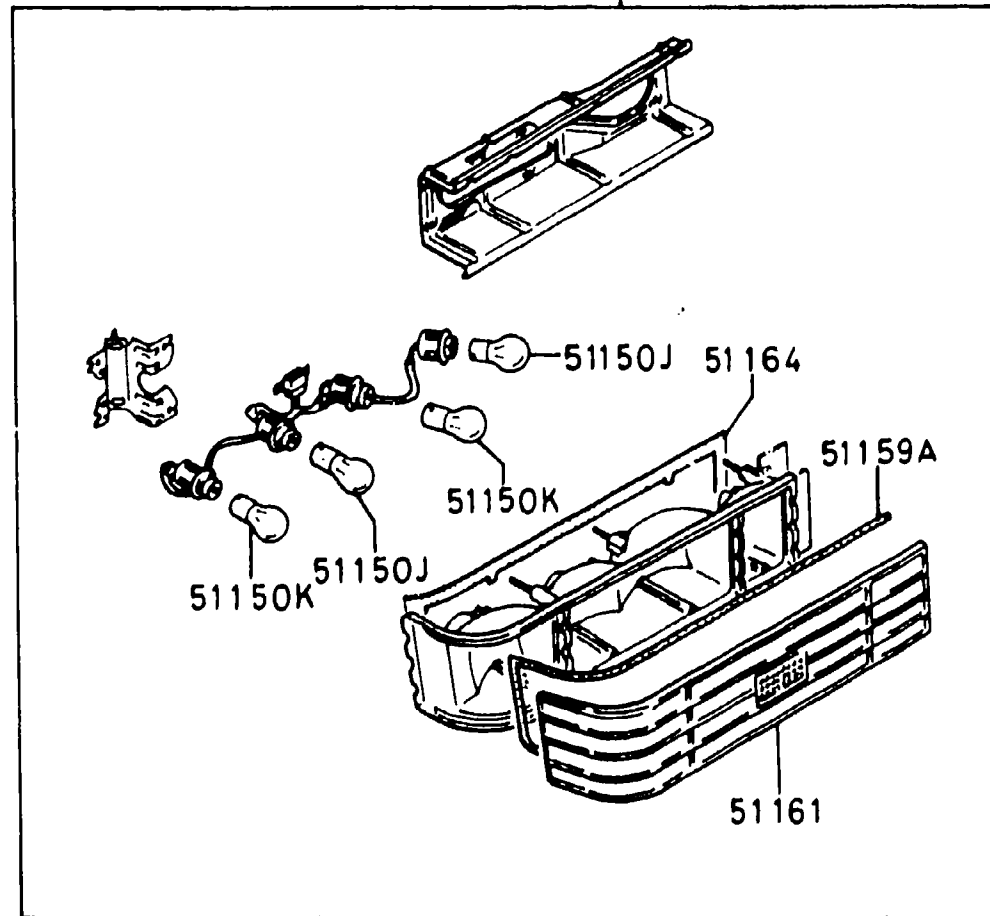

ITEM NO.	D-CODE	DESCRIPTION	PART NO.	QTY	MODEL/DESCRIPTION	REMARKS
	51 150J	BULB	0000-11-1156	4	(A12V 27W)	
	51 150K	BULB	0000-11-1157	4	(A12V 27/8W)	
	51 150S	LAMP SET (R), RR. COMB.	FA01-89-664	1		
	51 150T	LAMP SET (L), RR. COMB.	FA01-89-669	1		
	51 159A	PROTECTOR, RR. COMB.	FA01-51-159	2		
	51 161	LENS (R), RR. COMB.	FA01-51-151D	1		
		LENS (L), RR. COMB.	FA01-51-161D	1		
	51 164	GASKET (R), RR. COMB.	FA01-51-153A	1		
		GASKET (L), RR. COMB.	FA01-51-163A	1		

5120A-1 LICENSE & REAR SIDE TURN LAMPS

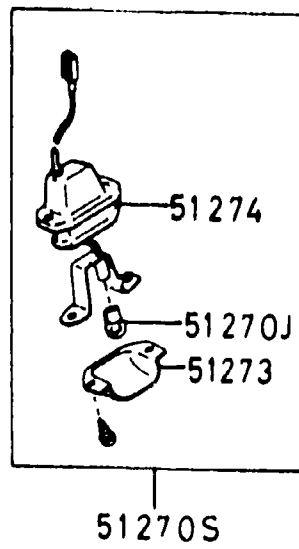
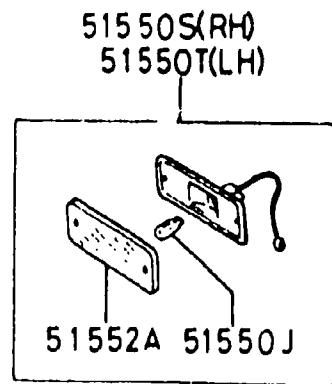
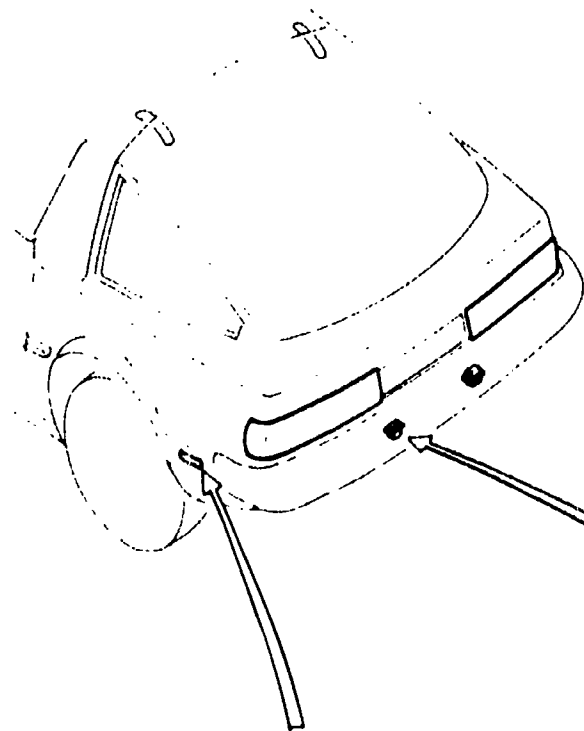

ITEM NO.	D-CODE	DESCRIPTION	PART NO.	QTY	MODEL/DESCRIPTION	REMARKS
	51 270J	BULB	9970-03-060T	2	(A12V 6W)	
	51 270S	LAMP SET, LICENSE	3874-89-665A	2		
	51 273	LENS, LICENSE LAMP	3874-66-371	2		
	51 274	GASKET, LICENSE LAMP	3874-66-373	2		
	51 550J	BULB	0000 11-0194	2	(A12V 3.8W)	
	51 550S	LAMP SET (R), SIDE TURN	FA01-89-673	1		
	51 550T	LAMP SET (L), SIDE TURN	FA01-89-678	1		
	51 552A	LENS (R), SIDE TURN	FA01-51-551	1		
		LENS (L), SIDE TURN	FA01-51-561	1		

SECTION INDEX -- BODY

STARTING LOCATION	SECT. NO.	SECTION NAME	STARTING LOCATION	SECT. NO.	SECTION NAME	STARTING LOCATION	SECT. NO.	SECTION NAME
2 - C 3	0900A	KEY SETS	2 - C 8	6132AC	CONDENSER PACKAGE ('83 MODEL)	2 - H 11	6870A	SERVICE TOOLS
2 - D 3	5000A	FRONT BUMPER	2 - E 8	6142A	COMPRESSOR MOUNTING KIT, COMPRESSOR/CLUTCH ASSEMBLY & REPAIR PARTS ('81 MODEL)	2 - I 11	6900A	VISOR, ASSIST HANDLE & MIRRORS
2 - E 3	5065A	RADIATOR GRILLE	2 - F 8	6142AB	COMPRESSOR MOUNTING KIT, COMPRESSOR/CLUTCH ASSEMBLY & REPAIR PARTS ('82 MODEL)	2 - L 11	6930A	CAUTION PLATES
2 - F 3	5010A	REAR BUMPER	2 - G 8	6142AC	COMPRESSOR MOUNTING KIT, COMPRESSOR/CLUTCH ASSEMBLY & REPAIR PARTS ('83 MODEL)			
2 - G 3	5030A	WINDOW MOULDINGS	2 - H 8	6152A	EVAPORATOR PACKAGE ('81 MODEL)			
2 - H 3	5040A	BODY MOULDINGS	2 - I 8	6152AB	EVAPORATOR PACKAGE ('82 MODEL)			
2 - I 3	5060A	SIDE PROTECTORS	2 - J 8	6152AC	EVAPORATOR PACKAGE ('83 MODEL)			
2 - J 3	5100A	HEAD LAMPS	2 - K 8	6230A	BACK DOOR MECHANISM			
2 - K 3	5103A	HEAD LAMP RETRACTORS	2 - L 8	6300A	WINDOW GLASSES			
2 - L 3	5105A	FRONT COMBINATION & SIDE TURN LAMPS	2 - M 8	6330A	SUNROOF (GSI)			
2 - M 3	5110A	REAR COMBINATION LAMPS	2 - N 8	6600A	SWITCH & RELAY (ENGINE & TRANSMISSION)			
2 - N 3	5120A	LICENSE & REAR SIDE TURN LAMPS	2 - C 9	6610A	DASHBOARD SWITCHES (MANUAL OPERATING)			
			2 - D 9	6611A	COMBINATION SWITCH			
2 - C 4	5125A	INTERIOR LAMPS (GS & GSI)	2 - E 9	6615A	POWER WINDOW SWITCH			
2 - D 4	5170A	ORNAMENTS	2 - F 9	6620A	DOOR, PARKING LAMP & KICK DOWN SWITCH			
2 - E 4	5180A	COWL & EXTRACTOR GRILLES	2 - G 9	6630A	RELAY (BODY)			
2 - F 4	5230A	HOOD	2 - H 9	6635A	HORN			
2 - G 4	5310A	BODY PANELS (FRONT)	2 - I 9	6640A	AUTO CRUISE CONTROL			
2 - I 4	5340A	BODY PANELS (SIDE & ROOF)	2 - J 9	6680A	AUDIO SYSTEM			
2 - J 4	5360A	BODY PANELS (FLOOR)	2 - M 9	6700A	WIRE HARNESS (FRONT & REAR)			
2 - K 4	5370A	FLOOR ATTACHMENTS	2 - N 9	6701A	WIRE HARNESS (ENGINE & TRANSMISSION)			
2 - L 4	5500A	DASHBOARD EQUIPMENT	2 - C 10	6702A	WIRE HARNESS (DASHBOARD)			
2 - N 4	5540A	METERS	2 - D 10	6703A	WIRE HARNESS (DOOR, FLOOR & CEILING)			
			2 - E 10	6704A	WIRE HARNESS CLAMPS			
2 - C 5	5560A	DASHBOARD & RELATED	2 - F 10	6720A	WINDSHIELD WASHER			
2 - E 5	5570A	CONSOLE	2 - G 10	6730A	WINDSHIELD WIPER			
2 - G 5	5580A	VENTILATOR	2 - H 10	6740A	WIPER MOTOR (COMPONENTS ONLY)			
2 - H 5	5700A	SEATS ('81 & '82) MODELS	2 - I 10	6750A	REAR WINDOW WIPER & WASHER			
2 - C 6	5700AA	SEATS ('83 MODEL)	2 - J 10	6760A	REAR WINDOW WIPER MOTOR (COMPONENTS ONLY)			
2 - H 6	5790A	SEAT BELTS	2 - K 10	6800A	CEILING TRIM			
2 - J 6	5800A	FRONT DOOR	2 - C 11	6840A	TRIM & SCUFF PLATE			
2 - K 6	5830A	FRONT DOOR MECHANISM	2 - F 11	6860A	FLOOR MATS & PADS			
2 - C 7	5840A	FRONT DOOR TRIM & RELATED PARTS						
2 - F 7	6100A	HEATER						
2 - G 7	6110A	HEATER UNIT						
2 - H 7	6115A	HEATER CONTROLS						
2 - I 7	6120A	HEATER BLOWER						
2 - J 7	6132A	CONDENSER PACKAGE ('81 MODEL)						
2 - L 7	6132AB	CONDENSER PACKAGE ('82 MODEL)						

5125A-1 INTERIOR LAMPS (GS & GSL)

ITEM NO.	D-CODE	DESCRIPTION	PART NO	QTY	MODEL/DESCRIPTION	REMARKS
	51 440A	LAMP, CARGO ROOM	FA01-51-440	1	GS & GSL MODELS	
	51 440J	BULB	0000-11-3022	1	(A12V 5W)	
	51 441	LENS	FA01-51-441	1		

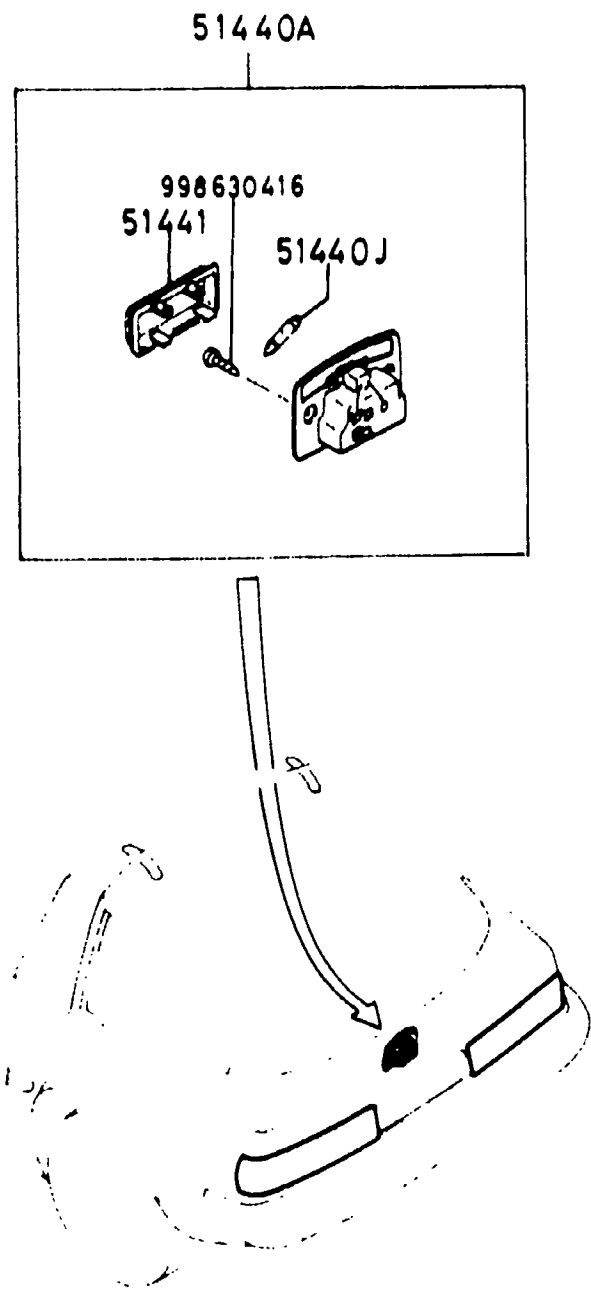

5170A-1 ORNAMENTS

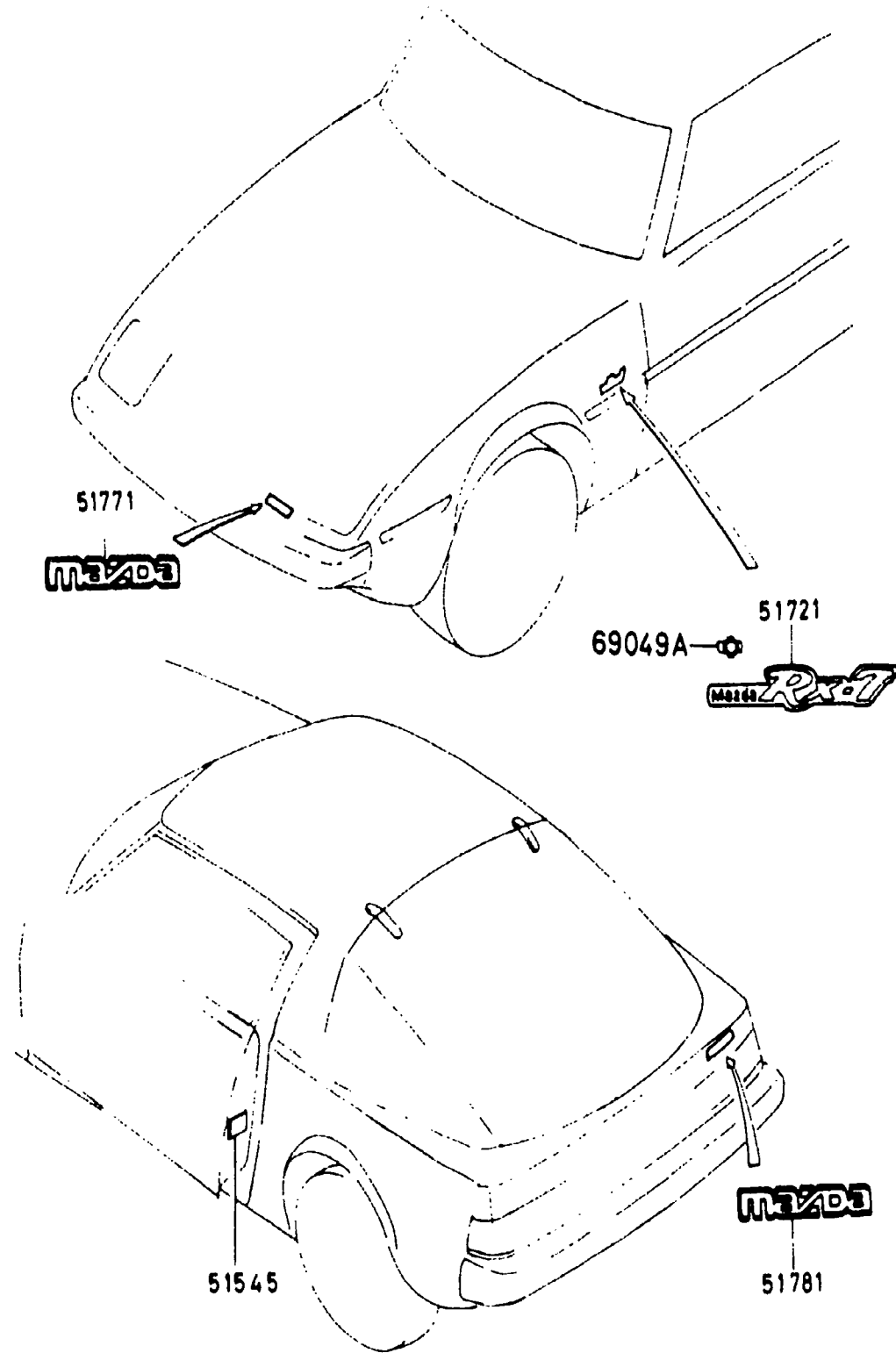

ITEM NO.	D-CODE	DESCRIPTION	PART NO.	QTY	MODEL/DESCRIPTION	REMARKS
51 545		REFLECTOR, DOOR	1243-51-545	1		
51 721		NAME, SIDE	8871-51-721	2		
51 771		ORNAMENT, FRONT	F001-51-771	1	(MAZDA)	
51 781		ORNAMENT, REAR	F001-51-781	1	(MAZDA)	
69 049A		NUT, SPEED	0187-69-049A	8		

5180A-1 COWL & EXTRACTOR GRILLES

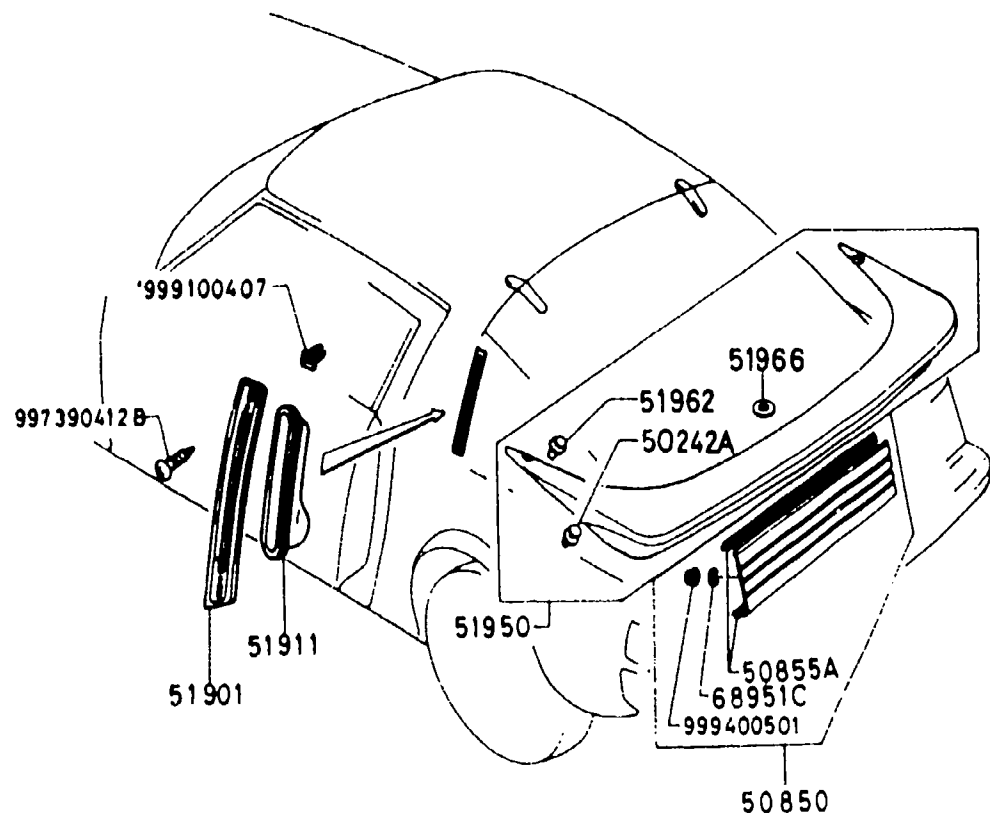
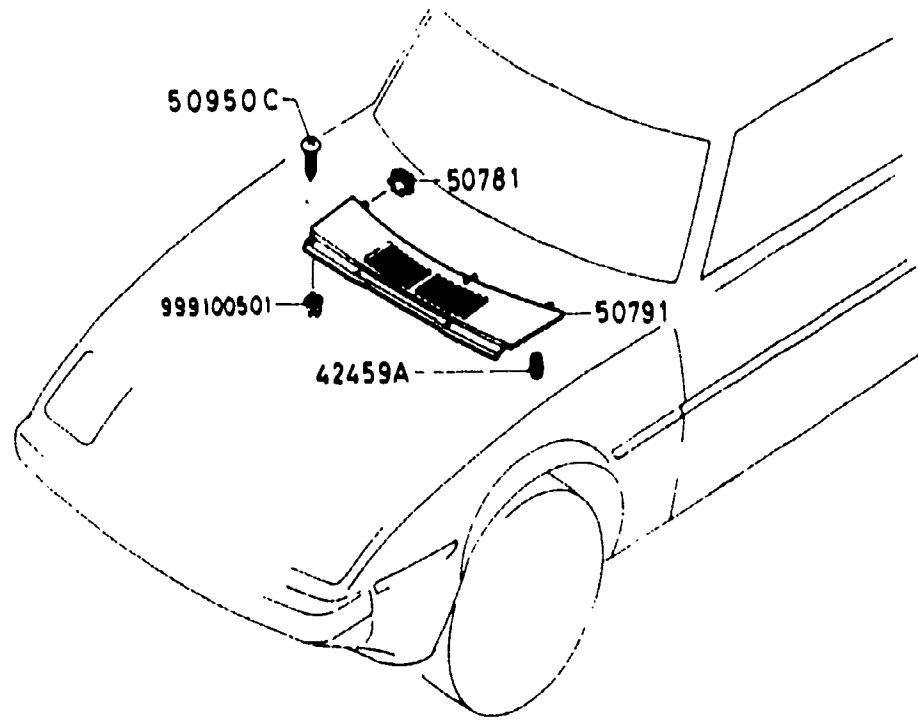

ITEM NO.	D-CODE	DESCRIPTION	PART NO.	QTY	MODEL/DESCRIPTION	REMARKS
	42 459A	RUBBER, CUSHION	0259-42-459	4		
	50 242A	FASTENER	G001-50-242	5		
	50 781	PROTECTOR, COWL GRILLE	8531-50-792	3		
	50 791	GRILLE, COWL	8871-50-791A	1		
	50 850	FINISHER, REAR	FA07-50-840C	1		
	50 855A	PROTECTOR, REAR FINISHER	FA01-50-855	2		
	50 950C	SCREW	G030-50-950	4		
	51 901	GRILLE (R), EXTRACTOR	8871-51-901C	1		
		GRILLE (L), EXTRACTOR	8871-51-951C	1		
	51 911	EXTRACTOR (R)	8871-51-911A	1		
		EXTRACTOR (L)	8871-51-961A	1		
	51 950	SPOILER, REAR	FA16-51-960B	1		
	51 962	GROMMET, SCREW	FA16-51-962A	2		
	51 966	PROTECTOR	FA16-51-966	6		FB331 ..507335-
	68 951C	PACKING	0305-68-951	2		

5230A-1 HOOD

ITEM NO.	D-CODE	DESCRIPTION	PART NO.	QTY	MODEL/DESCRIPTION	REMARKS
	52 302	CLAMP, RELEASE WIRE	0223-52-302	1		
	52 310	HOOD	8871-74-250	1		
	52 397	RUBBER, CUSHION	0187-52-231	2		
	52 410A	HINGE, HOOD	8871-52-410	2		
	52 510	STAY, HOOD	8871-52-511B	1		
	52 518	HOLDER, HOOD STAY	8871-52-518	1		
	52 672	SPRING, RETURN	1011-56-672A	1		
	52 863	SPRING, RETURN	0305-52-863B	1		
	53 771	RUBBER, CUSHION	8545-56-801A	2		
			<AN> 8545-56-801B	2		
	56 620	LOCK, HOOD	1708-56-620D	1		
	56 710	WIRE, RELEASE-HOOD	8871-56-710A	1		
	56 785	CUSHION	8871-56-785	1		
	56 787	WEATHERSTRIP, HOOD	8871-56-787A	1		

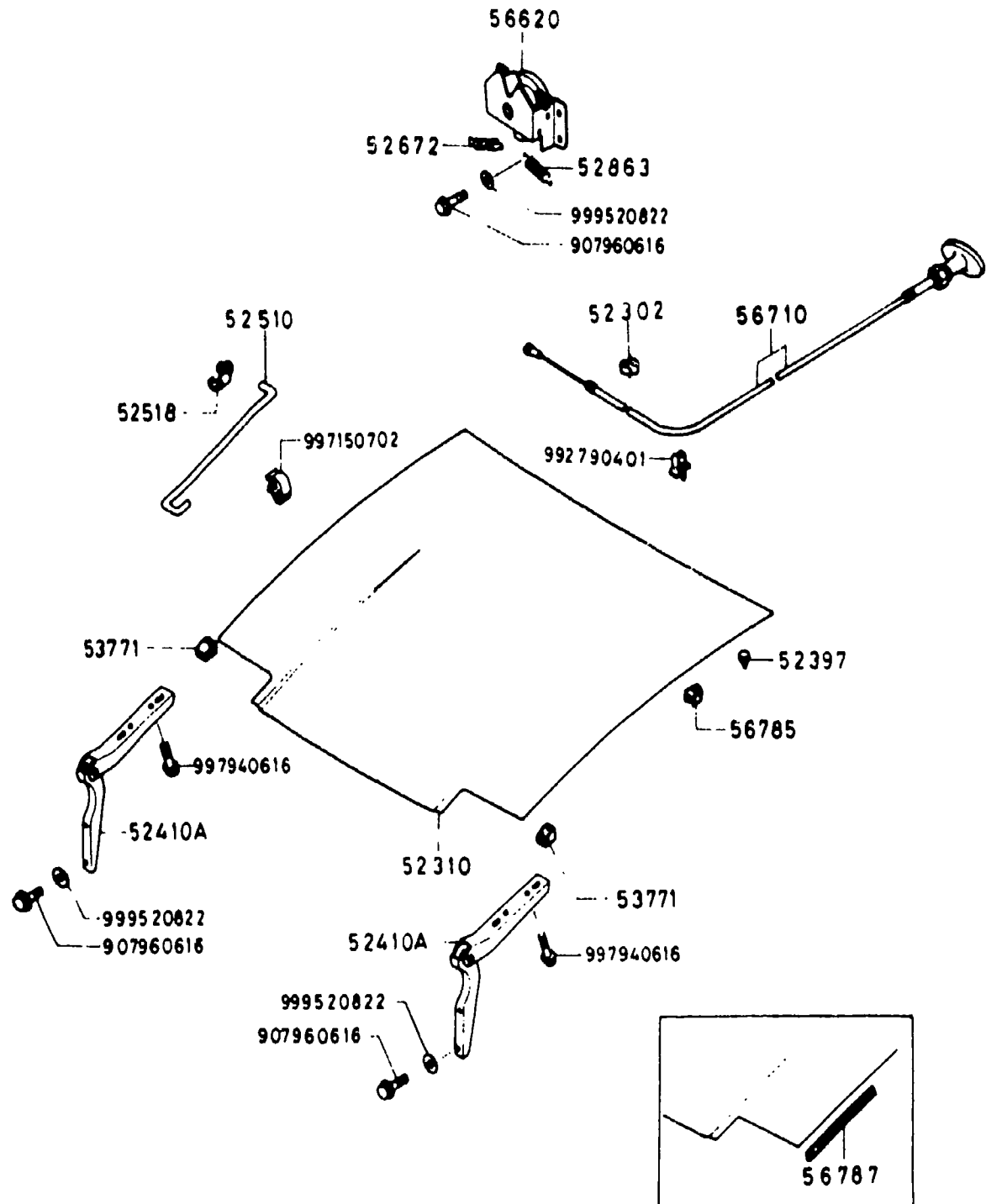

5310A-1 BODY PANELS (FRONT)

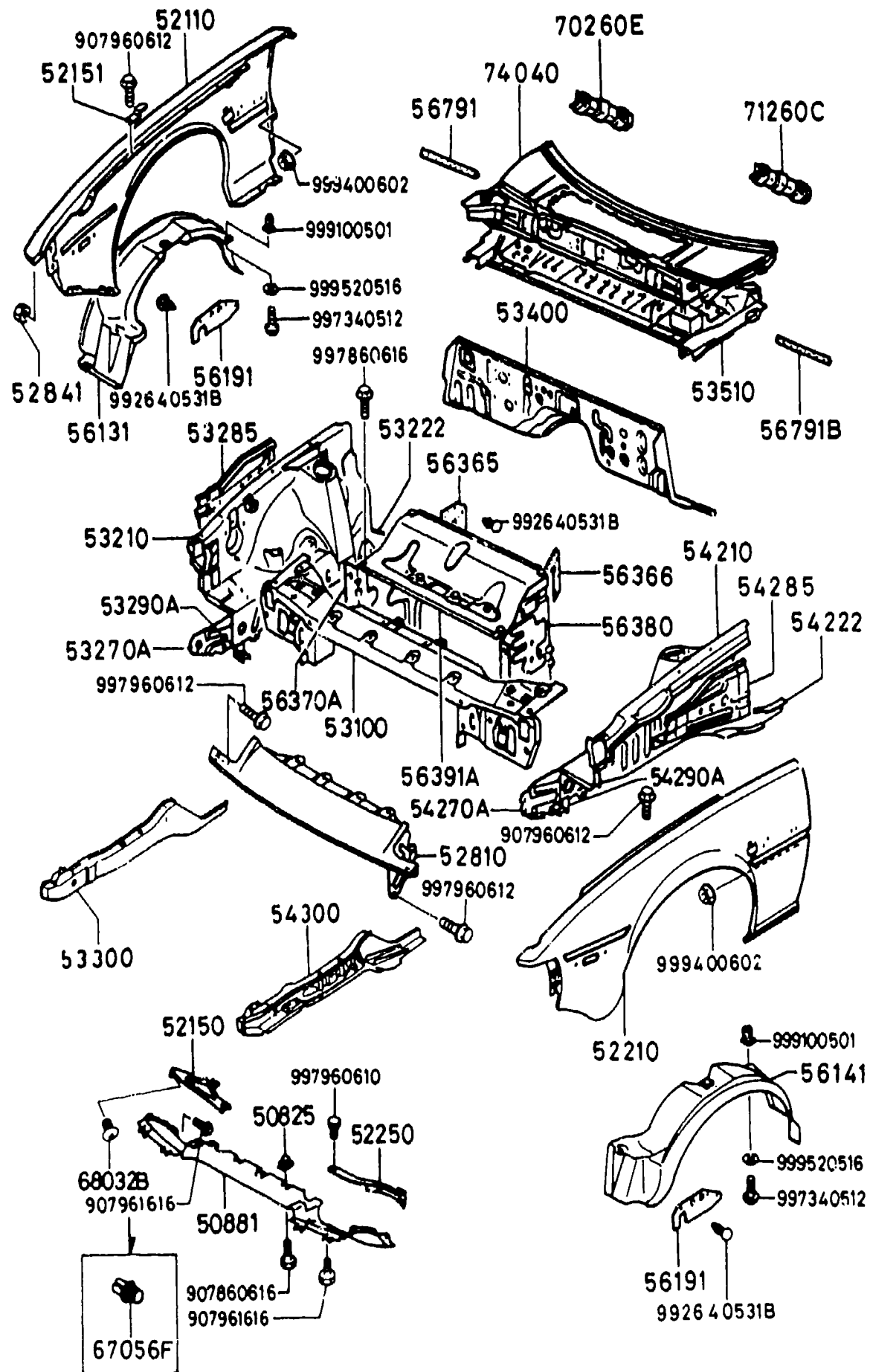

ITEM NO.	D-CODE	DESCRIPTION	PART NO.	QTY	MODEL/DESCRIPTION	REMARKS
50 825		NUT, CLIP	8871-50-825	4		
50 881		SPOILER, FRONT	FA01-51-980B	1		
52 110		PANEL (R), FENDER-FRONT	FA01-52-111D	1		
52 150		STAY (R), FENDER	FA01-52-130A	1		
52 151		PLATE, SET-FENDER	8871-52-151	1		
52 210		PANEL (L), FENDER-FRONT	FA01-52-211D	1		
52 250		STAY (L), FENDER	FA01-52-230A	1		
52 810		PANEL, NOSE	8871-52-810G	1		
52 841		NUT, CLIP-FRONT FENDER	8545-52-841	2		
53 100		PANEL, RADIATOR SHROUD	FA54-53-100	1		
53 210		PANEL (R), WHEEL APRON	F003-53-210G	1		
53 222		PLATE (R), CLOSING-REAR	8871-53-240A	1		
53 270A		PLATE (R), CLOSING	FA01-53-270A	1		
53 285		REINFORCEMENT (R), WHEEL APRON	8871-53-285C	1		
53 290A		BRACKET (R), FENDER	FA01-53-290	1		
53 300		FRAME (R), SIDE-FRONT	FA01-53-310H	1		
53 400		PANEL, DASH-LOWER	FA01-53-400E	1		
53 510		PANEL, DASH-UPPER	FA01-53-510	1		
54 210		PANEL (L), WHEEL APRON	F003-54-210G	1		
54 222		PLATE (L), CLOSING-REAR	8871-54-240A	1		
54 270A		PLATE (L), CLOSING	FA01-54-270A	1		
54 285		REINFORCEMENT (L), WHEEL APRON	8871-54-285C	1		
54 290A		BRACKET (L), FENDER	FA01-54-290	1		
54 300		FRAME (L), SIDE-FRONT	FA01-54-310H	1		
56 131		SHIELD (R), SPLASH	FA01-56-130	1		
56 141		SHIELD (L), SPLASH	FA01-56-140	1		
56 191		SHIELD, SPLASH	8871-55-191C	2		
56 365		PLATE (R), SEAL	8871-56-365	1		
56 366		PLATE (L), SEAL	8871-56-366	1		
56 370A		PANEL (R), SIDE	8871-56-370D	1		
56 380		PANEL (L), SIDE	8871-56-380D	1		
56 391A		PANEL, COWLING UP	8871-56-391	1		
56 791		RUBBER (R), SEAL	8871-56-791A	1		
56 791B		RUBBER (L), SEAL	8871-56-792A	1		
67 056F		RIVET	W023-67-056	2	'82 & '83 MODELS	FB331 ..605980-
68 032B		FASTENER	8001-68-032	2		
		BLACK	00			
		WHITE	08			
70 260E		BRACKET (R), INSTRUMENTATION	8871-70-260	1		

5310A-2 BODY PANELS (FRONT)

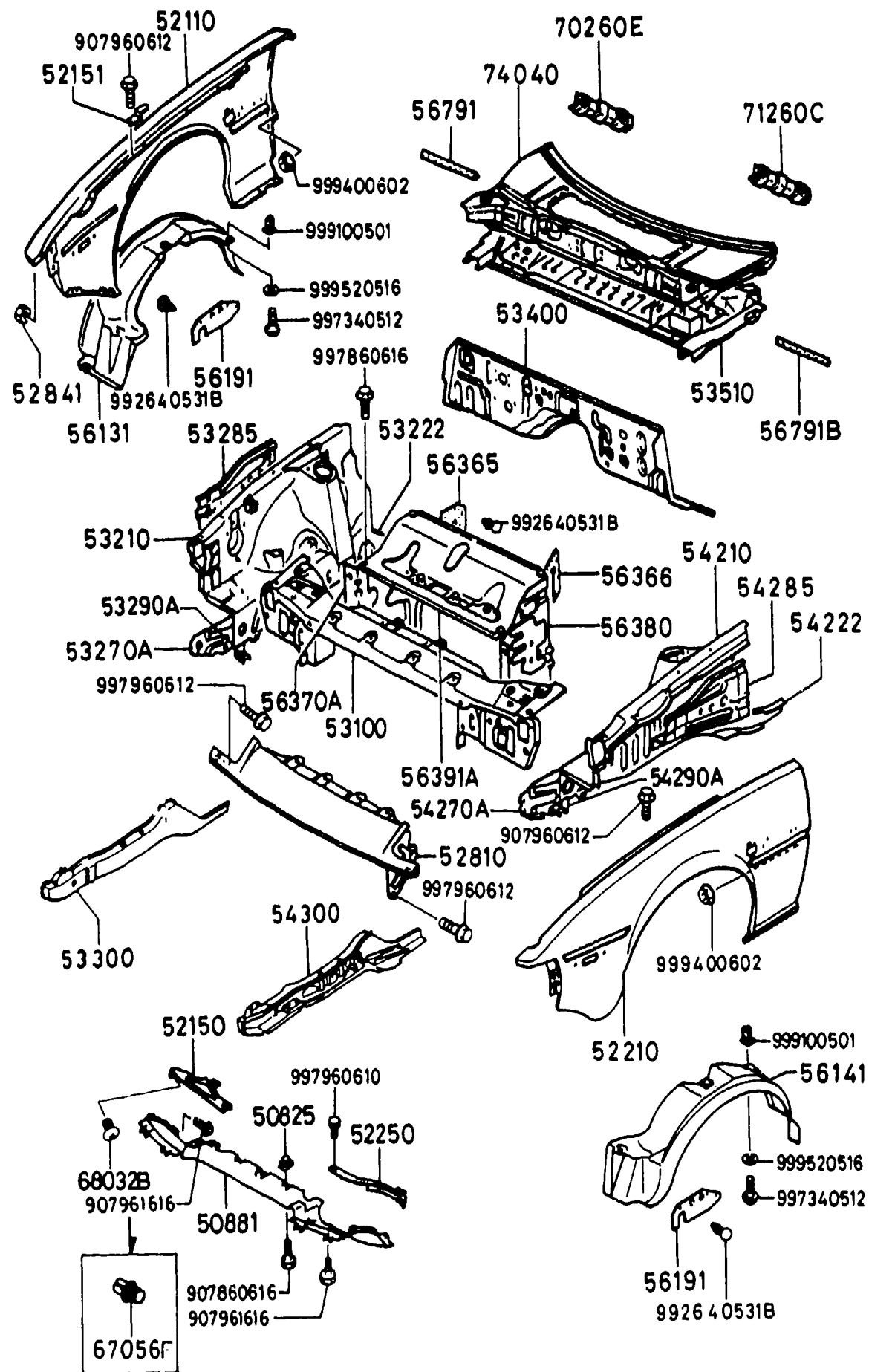

ITEM NO.	D-CODE	DESCRIPTION	PART NO.	QTY	MODEL/DESCRIPTION	REMARKS
	71 260C	BRACKET (L), INSTRUMENTATION	8871-71-260	1		
	74 040	PANEL, COWL	FA01-74-040A	1		

5340A-1 BODY PANELS (SIDE & ROOF)

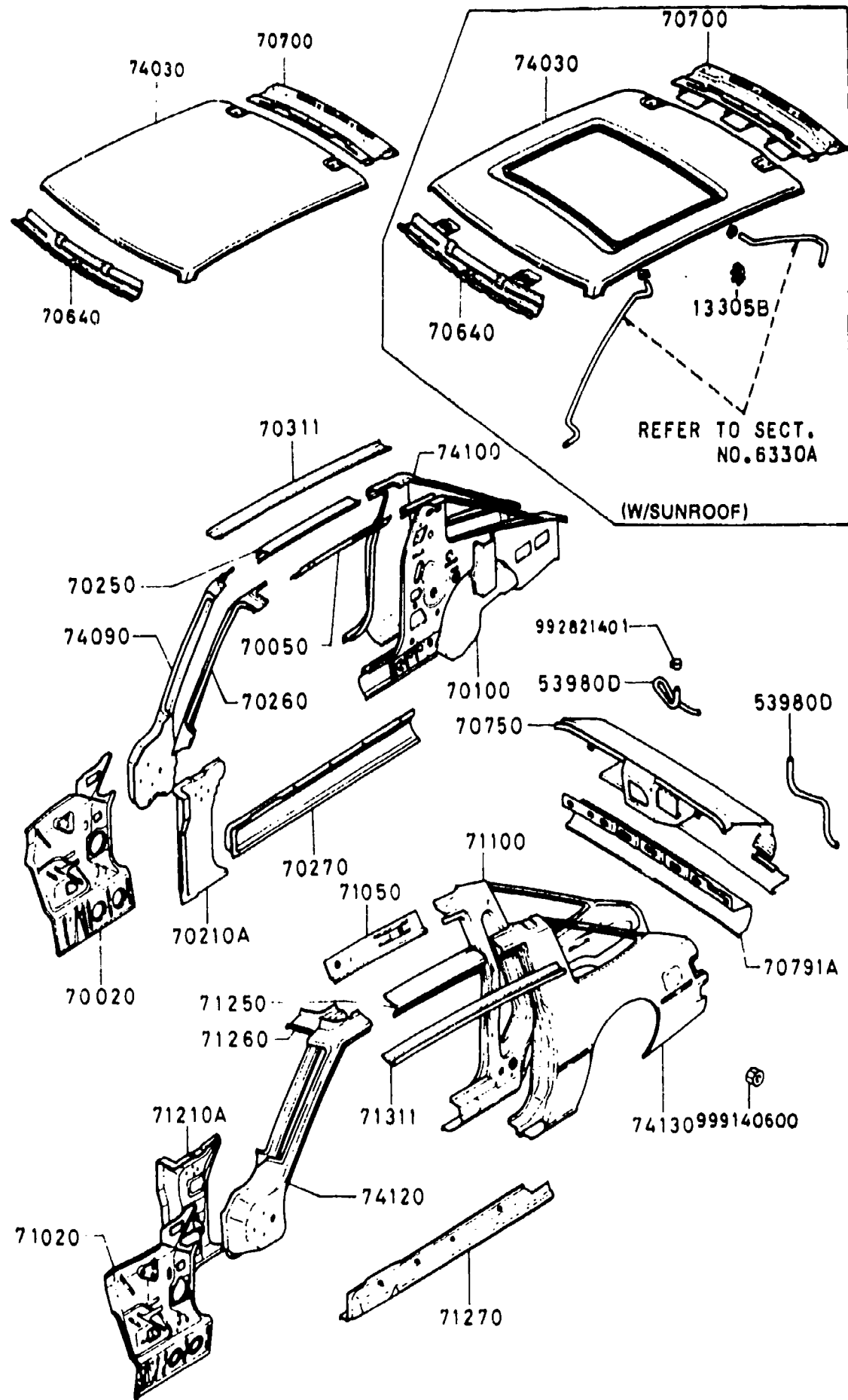

ITEM NO.	D-CODE	DESCRIPTION	PART NO.	QTY	MODEL/DESCRIPTION	REMARKS
	13 305B	CLIP, DRAIN HOSE	8871-13-305	2	SUNROOF	
	53 980D	HOSE, DRAIN-REAR	8871-56-751A	2		
	70 020	PANEL (R), COWL SIDE	8871-70-020E	1		
	70 050	RAIL (R), ROOF-INNER	8871-70-051D	1		
	70 100	PANEL (R), QUARTER	FA01-70-100I	1		
	70 210A	PILLAR (R), HINGE	FA54-70-210A	1		
	70 250	RAIL (R), ROOF-OUTER	8871-70-251	1		
	70 260	PILLAR (R), FRT.-INNER	8871-70-240C	1		
	70 270	PANEL (R), SIDE SILL	8871-70-271B	1		
	70 311	RAIL (R), RAIN	8871-70-311A	1		
	70 640	HEADER, FRONT	8871-70-640A	1	NORM. ROOF	
			8973-70-640A	1	SUNROOF	
	70 700	HEADER, REAR	FA01-70-700A	1	NORM. ROOF	
			FA04-70-700A	1	SUNROOF	
	70 750	PANEL, REAR END	FA01-70-750C	1		
	70 791A	PANEL, SKIRT-REAR	FA01-70-791	1		
	71 020	PANEL (L), COWL SIDE	FA16-71-020C	1		
	71 050	RAIL (L), ROOF-INNER	8871-71-051D	1		
	71 100	PANEL (L), QUARTER	FA01-71-100I	1		
	71 210A	PILLAR (L), HINGE	FA54-71-210B	1		
	71 250	RAIL (L), ROOF-OUTER	8871-71-251	1		
	71 260	PILLAR (L), FRT.-INNER	8871-71-240C	1		
	71 270	PANEL (L), SIDE SILL	8871-71-271B	1		
	71 311	RAIL (L), RAIN	8871-71-311A	1		
	74 030	PANEL, ROOF	1482-74-030	1	SUNROOF	
			8871-74-030	1	NORM. ROOF	
	74 090	PILLAR (R), HINGE-OUTER	8871-70-220C	1		
	74 100	PANEL (R), FENDER-REAR	FA01-70-400A	1		
	74 120	PILLAR (L), HINGE-OUTER	8871-71-220C	1		
	74 130	PANEL (L), FENDER-REAR	FA01-71-400B	1	'81 & '82 MODELS	
			FA42-71-400B	1	'83 MODEL	

5360A-1 BODY PANELS (FLOOR)

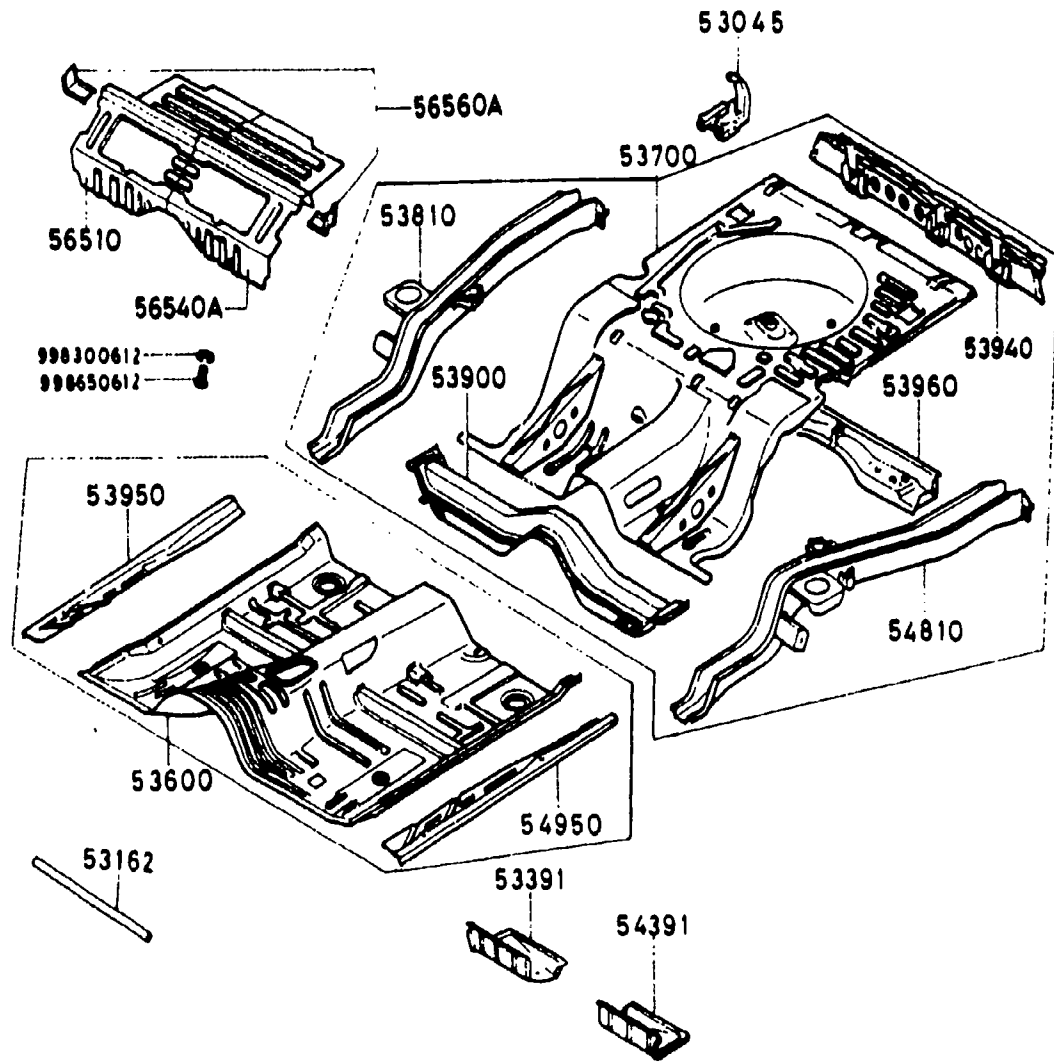

ITEM NO.	D-CODE	DESCRIPTION	PART NO.	QTY	MODEL/DESCRIPTION	REMARKS
	53 045	BRACKET, JACK	8871-53-050A	1		
	53 162	MEMBER, CROSS	8871-53-161	1		
	53 391	BOX (R), TORQUE	FA01-53-391B	1		
	53 600	PAN, FLOOR-FRONT	FA01-53-600B	1		
	53 700	PAN, FLOOR-REAR	FA01-53-700G	1		
	53 810	FRAME (R), REAR SIDE	FA01-53-810D	1		
	53 900	MEMBER NO. 3, CROSS	FA01-53-900A	1		
	53 940	MEMBER NO. 4, CROSS	FA01-53-940E	1		
		<C>	FA01-53-940F			REQUIRES BOLT (2): 9978-01-025 & WASHER (2): 9995-21-000
	53 950	PANEL (R), SIDE SILL	8871-53-951B	1		
	53 960	MEMBER NO. 5, CROSS	FA54-53-930	1		
	54 391	BOX (L), TORQUE	8871-54-391C	1		
	54 810	FRAME (L), REAR SIDE	FA01-54-810H	1		
	54 950	PANEL (L), SIDE SEAL	8871-54-951A	1		
	56 510	DECK (R), FLOOR	FA01-56-510	1		
	56 540A	DECK (L), FLOOR	FA01-56-541A	1		
	56 560A	BRACKET, DECK	8871-56-560A	2		

5370A-1 FLOOR ATTACHMENTS

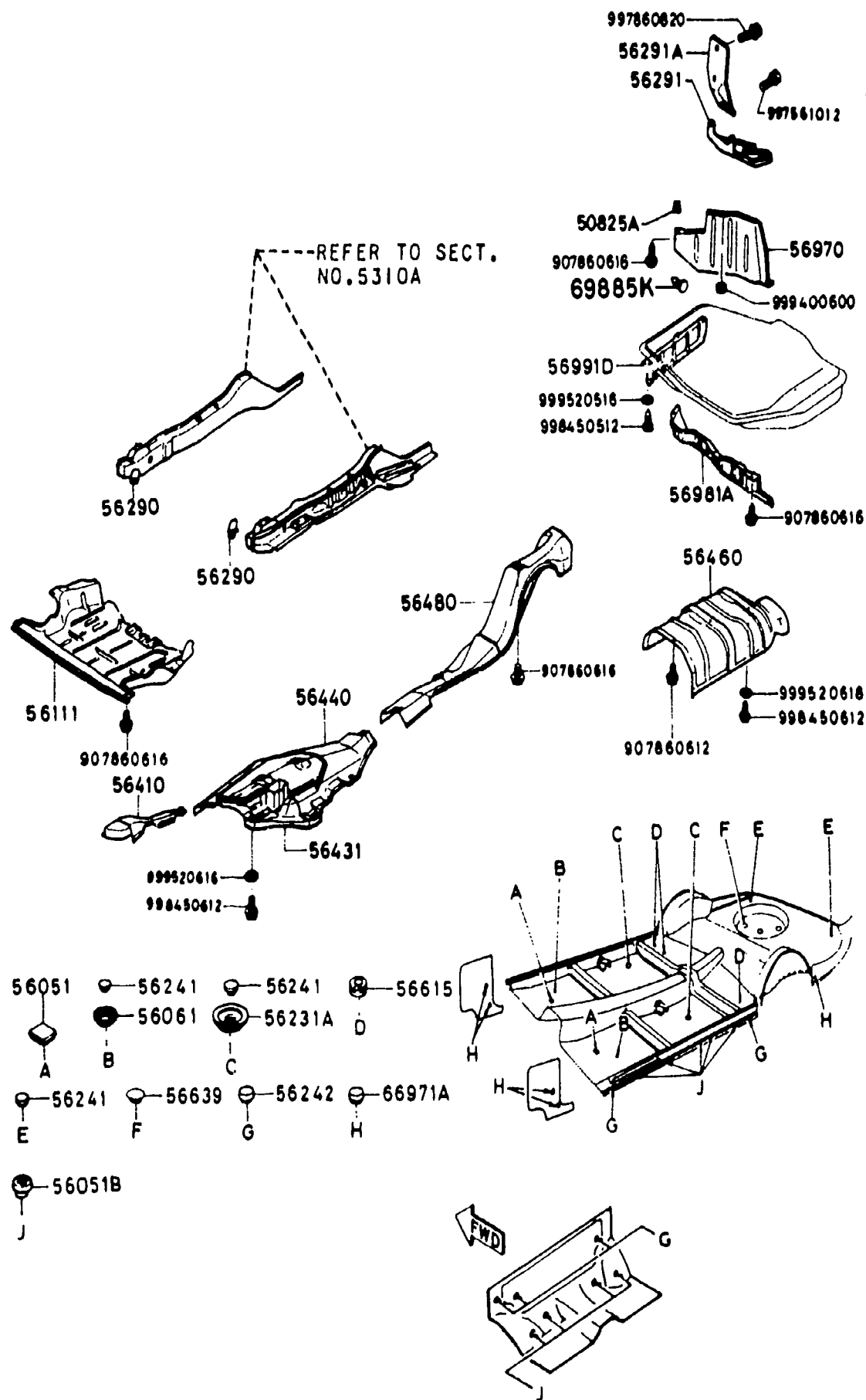

ITEM NO.	D-CODE	DESCRIPTION	PART NO.	QTY	MODEL/DESCRIPTION	REMARKS
	50 825A	NUT, CLIP-PROTECTOR	8871-50-825	1		
	56 051	COVER, HOLE	1011-56-051	2		
	56 051B	COVER, HOLE	B001-56-051	10	(PLASTIC) '82 & '83 MODELS	FB331 ..633361-
	56 061	COVER, SERVICE HOLE	8545-56-052	2		
	56 111	COVER, UNDER	FA54-56-111C	1		
	56 231A	COVER, SERVICE HOLE	8545-56-053	2		
	56 241	PLUG, DRAIN	0118-56-241	18	'81 & '82 MODELS	
				8	'83 MODEL	
	56 242	PLUG, DRAIN	0118-56-242B	3		
	56 290	HOOK (R), FRONT	FA01-53-170B	1		
		HOOK (L), FRONT	FA01-54-170B	1		
	56 291	HOOK, REAR	8871-56-271E	1		
	56 291A	HOOK, TIE DOWN	8871-56-281B	1	'81 & '82 MODELS	FB331 ..500001-622565
			< A >	1	'82 & '83 MODELS	FB331 ..622566-
	56 410	INSULATOR, HEAT-FRONT	1480-56-430B	1		
	56 431	INSULATOR, HEAT	1480-56-451B	1		
	56 440	INSULATOR NO. 2, FRONT	1480-56-440C	1		
	56 460	INSULATOR NO. 4, REAR	8871-56-420E	1		
	56 480	INSULATOR NO. 1, REAR	1480-56-410A	1		
	56 615	PLUG, DRAIN	0222-61-622	3		
	56 639	COVER, SERVICE HOLE	0810-56-639	3		
	56 970	PROTECTOR, FUEL TANK	8871-56-970D	1		
	56 981A	INSULATOR	8871-56-981C	1		
	56 991D	INSULATOR, TANK-FUEL	8871-56-990A	1		
	66 971A	RUBBER, SEAL	0222-66-971	2		
	69 885K	FASTENER, PROTECTOR	0866-69-885A	1		
		BLACK	00			

5500A-1 DASHBOARD EQUIPMENT

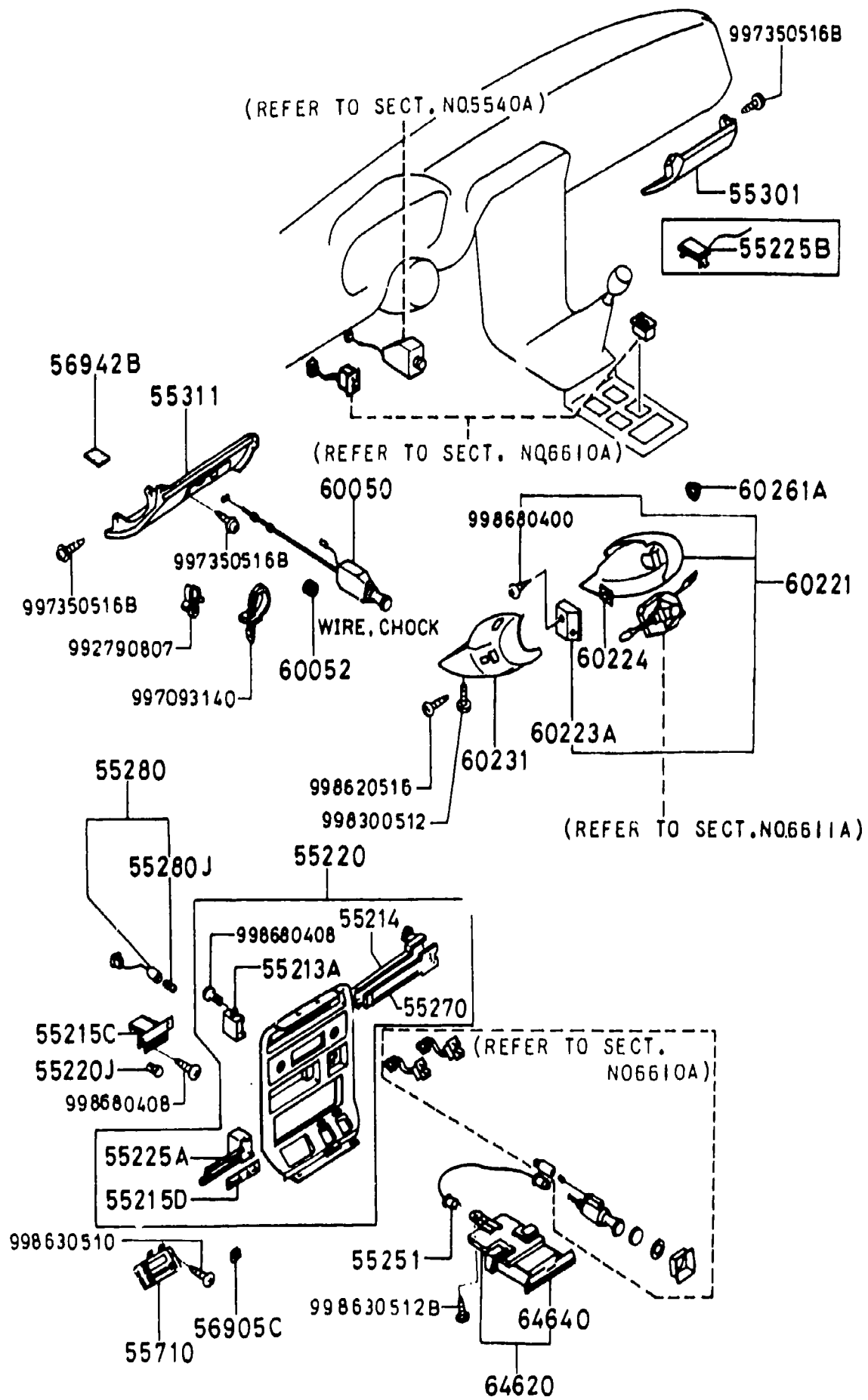

ITEM NO.	D-CODE	DESCRIPTION	PART NO.	QTY	MODEL/DESCRIPTION	REMARKS
	55 213A	CASE, LAMP	8249-55-213	1		
	55 214	PLATE, RETAINER	F023-55-214	1	'83 MODEL	
	55 215C	LENS, ASH TRAY	FA01-55-221	1		
	55 215D	PANEL, DECORATION-SWITCH	FA01-55-215A	1		
	55 220	PANEL, CENTER	FA01-55-210	1	(USE W/O FULL CONTROL) '81 & '82 MODELS	FB331 ..500001-633360
		SILVER METALLIC	01			
			FA02-55-210	1	(USE W/ FULL CONTROL) '81 & '82 MODELS	
		SILVER METALLIC	01			
			FA30-55-210	1	(USE W/O FULL CONTROL) (ETR STEREO) '82 MODEL, GSL MODEL	FB331 ..633361-
		SILVER METALLIC/BLACK	01			
			FA42-55-210A	1	(USE W/O FULL CONTROL) '83 MODEL	
		SILVER METALLIC	01			
			FA43-55-210A	1	(USE W/ FULL CONTROL) '83 MODEL	
		SILVER METALLIC	01			
	55 220J	BULB	0000-11-0194	1	(A12V 3.4W)	
	55 225A	BOX, LAMP	FA01-55-216	1		
	55 225B	COVER, HOLE	B001-55-225A	4	(W/O REAR WIPER, HATCHBACK OPENER & A.C.C.) S MODEL	
	55 251	FIBER, OPTICAL	FA01-55-251	1		
	55 270	PANEL, DECORATION	FA01-55-212	1	'81 & '82 MODELS	
			F023-55-212	1	'83 MODEL	
	55 280	BULB & SOCKET	8871-55-280	2		
	55 280J	BULB	0000-11-0074	2	(1.4W)	
	55 301	PANEL, GLOVE SIDE	FA01-55-310	1		
		BLACK	00			
		RED	10			
		TAN	29			FB331 ..600001-700000
		BROWN	70			
		DARK TAN	81			FB331 ..700001-
	55 311	PANEL, SWITCH	FA01-55-327A	1		
		BLACK	00			
		RED	10			
		TAN	29			FB331 ..600001-700000
		BROWN	70			

5500A-2 DASHBOARD EQUIPMENT

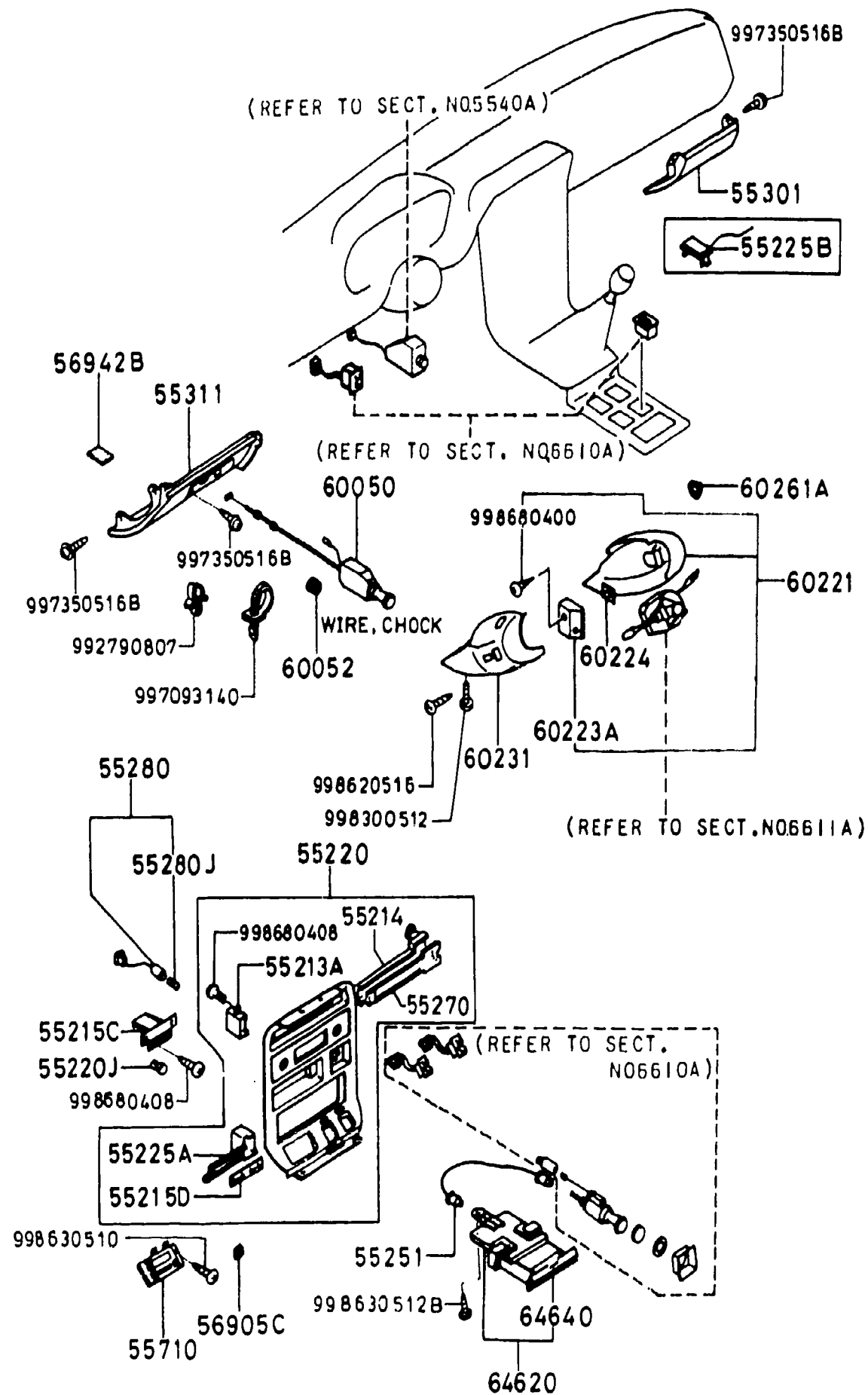

ITEM NO.	D-CODE	DESCRIPTION	PART NO.	QTY	MODEL/DESCRIPTION	REMARKS
55 311 (CONT'D)		DARK TAN	81			FB331 ..70001-
55 710		CLOCK, AUTO	FA01-55-710	1	(DIGITAL TYPE) GS & GSI MODELS	
			FA02-55-710	1	(ANALOG TYPE) S MODEL	
56 905C		NUT, SPRING	0820-56-905	2		
56 942B		PAD, CHOKE WIRE	G001-67-061	1		
60 050		WIRE, CHOKE	8871-60-050A	1		
60 052		GROMMET, CHOKE WIRE	0305-60-052A	1		
60 221		COVER (R), COLUMN	FA01-60-220	1		
60 223A		COVER, LAMP	FA01-60-241	1		
60 224		LENS, LAMP	FA01-60-242	1		
60 231		COVER (L), COLUMN	FA01-60-230	1		
60 261A		HOLDER, KEY CYLINDER	G001-60-261	1		
64 620		TRAY, ASH BLACK	FA01-64-610 00	1		
64 640		TRAY, ASH-INNER BLACK	FA01-64-630 00	1		

5540A-1 METERS

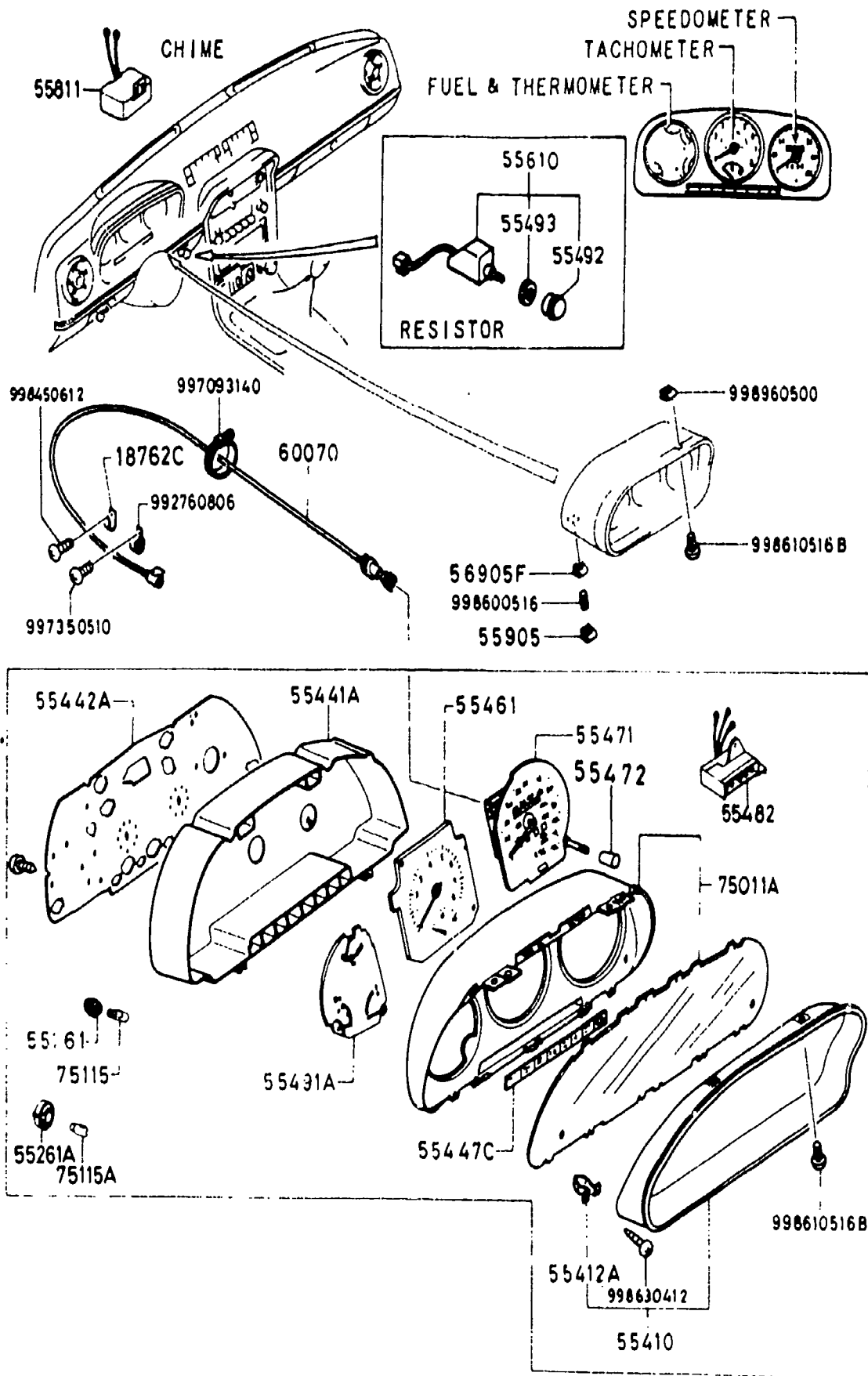

ITEM NO.	D-CODE	DESCRIPTION	PART NO.	QTY	MODEL/DESCRIPTION	REMARKS
	18 762C	CLIP	8173-18-762	1		
	55 261	SOCKET	1316-55-261	9		
	55 261A	SOCKET	3625-55-261	6		
	55 410	HOOD, METER	8871-55-420A	1		
	55 412A	SPRING, METER HOOD	8531-55-412	2		
	55 441A	CASE, METER	FA01-55-441	1	'81 & '82 MODELS	
			F023-55-441B	1	'83 MODEL	
	55 442A	PLATE, PRINT	FA01-55-442	1	'81 MODEL	
			FA33-55-442	1	'82 MODEL	
			FA44-55-442B	1	'83 MODEL	
	55 447C	LENS, WARNING	FA01-55-444	1		
	55 461	TACHOMETER	FA01-55-461	1		
	55 471	SPEEDOMETER	FA01-55-471	1	(85MPH & 140KMH) '81 MODEL	
			FA33-55-471	1	'82 MODEL	
			FA44-55-471A	1	(USE W/ FULL CONTROL) '83 MODEL	
	55 472	KNOB, TRIPMETER	1907-75-102A	1		
	55 482	REGULATOR	FA01-55-482	1		
	55 491A	METER, FUEL & TEMPERATURE	FA27-55-481	1		
	55 492	KNOB, RESISTOR	FA01-55-492	1		
	55 493	NUT, RING	FA01-55-493	1		
	55 610	RESISTOR	FA01-55-490	1		
	55 811	CHIME	FA01-55-811A	1		
	55 905	NUT, SPRING	8871-55-425	2		
	56 905F	NUT, SPRING	0820-56-905	2		
	60 070	CABLE, SPEEDOMETER	8871-60-070B	1		
	75 011A	PLATE, WINDOW	FA01-55-446	1		
	75 115	BULB	0000-11-0194	9	(A12V 3.4W)	
	75 115A	BULB	0000-11-0074	8	(1.4W)	

SECTION INDEX -- BODY

STARTING LOCATION	SECT. NO.	SECTION NAME	STARTING LOCATION	SECT. NO.	SECTION NAME	STARTING LOCATION	SECT. NO.	SECTION NAME
2 - C 3	0900A	KEY SETS	2 - C 8	6132AC	CONDENSER PACKAGE ('83 MODEL)	2 - H11	6870A	SERVICE TOOLS
2 - D 3	5000A	FRONT BUMPER	2 - E 8	6142A	COMPRESSOR MOUNTING KIT, COMPRESSOR/CLUTCH ASSEMBLY & REPAIR PARTS ('81 MODEL)	2 - I11	6900A	VISOR, ASSIST HANDLE & MIRRORS
2 - E 3	5005A	RADIATOR GRILLE	2 - F 8	6142AB	COMPRESSOR MOUNTING KIT, COMPRESSOR/CLUTCH ASSEMBLY & REPAIR PARTS ('82 MODEL)	2 - I11	6930A	CAUTION PLATES
2 - F 3	5010A	REAR BUMPER	2 - G 8	6142AC	COMPRESSOR MOUNTING KIT, COMPRESSOR/CLUTCH ASSEMBLY & REPAIR PARTS ('83 MODEL)			
2 - G 3	5030A	WINDOW MOULDINGS	2 - H 8	6152A	EVAPORATOR PACKAGE ('81 MODEL)			
2 - H 3	5040A	BODY MOULDINGS	2 - I 8	6152AB	EVAPORATOR PACKAGE ('82 MODEL)			
2 - J 3	5060A	SIDE PROTECTORS	2 - J 8	6152AC	EVAPORATOR PACKAGE ('83 MODEL)			
2 - J 3	5100A	HEAD LAMPS	2 - K 8	6230A	BACK DOOR MECHANISM			
2 - K 3	5103A	HEAD LAMP RETRACTORS	2 - L 8	6300A	WINDOW GLASSES			
2 - L 3	5105A	FRONT COMBINATION & SIDE TURN LAMPS	2 - M 8	6330A	SUNROOF (GSI)			
2 - M 3	5110A	REAR COMBINATION LAMPS	2 - N 8	6600A	SWITCH & RELAY (ENGINE & TRANSMISSION)			
2 - N 3	5120A	LICENSE & REAR SIDE TURN LAMPS	2 - C 9	6610A	DASHBOARD SWITCHES (MANUAL OPERATING)			
2 - C 4	5125A	INTERIOR LAMPS (GS & GSI)	2 - D 9	6611A	COMBINATION SWITCH			
2 - D 4	5170A	ORNAMENTS	2 - E 9	6615A	POWER WINDOW SWITCH			
2 - E 4	5180A	COWL & EXTRACTOR GRILLES	2 - F 9	6620A	DOOR, PARKING LAMP & KICK DOWN SWITCH			
2 - F 4	5230A	HOOD	2 - G 9	6630A	RELAY (BODY)			
2 - G 4	5310A	BODY PANELS (FRONT)	2 - H 9	6635A	HORN			
2 - I 4	5340A	BODY PANELS (SIDE & ROOF)	2 - I 9	6640A	AUTO CRUISE CONTROL			
2 - J 4	5360A	BODY PANELS (FLOOR)	2 - J 9	6680A	AUDIO SYSTEM			
2 - K 4	5370A	FLOOR ATTACHMENTS	2 - M 9	6700A	WIRE HARNESS (FRONT & REAR)			
2 - L 4	5500A	DASHBOARD EQUIPMENT	2 - N 9	6701A	WIRE HARNESS (ENGINE & TRANSMISSION)			
2 - N 4	5540A	METERS	2 - C10	6702A	WIRE HARNESS (DASHBOARD)			
2 - C 5	5560A	DASHBOARD & RELATED	2 - D10	6703A	WIRE HARNESS (DOOR, FLOOR & CEILING)			
2 - E 5	5570A	CONSOLE	2 - E10	6704A	WIRE HARNESS CLAMPS			
2 - G 5	5580A	VENTILATOR	2 - F10	6720A	WINDSHIELD WASHER			
2 - H 5	5700A	SEATS ('81 & '82) MODELS	2 - G10	6730A	WINDSHIELD WIPER			
2 - C 6	5700AA	SEATS ('83 MODEL)	2 - H10	6740A	WIPER MOTOR (COMPONENTS ONLY)			
2 - H 6	5790A	SEAT BELTS	2 - I10	6750A	REAR WINDOW WIPER & WASHER			
2 - J 6	5800A	FRONT DOOR	2 - J10	6760A	REAR WINDOW WIPER MOTOR (COMPONENTS ONLY)			
2 - K 6	5830A	FRONT DOOR MECHANISM	2 - K10	6800A	CEILING TRIM			
2 - C 7	5840A	FRONT DOOR TRIM & RELATED PARTS	2 - C11	6840A	TRIM & SCUFF PLATE			
2 - F 7	6100A	HEATER	2 - F11	6860A	FLOOR MATS & PADS			
2 - G 7	6110A	HEATER UNIT						
2 - H 7	6115A	HEATER CONTROLS						
2 - I 7	6120A	HEATER BLOWER						
2 - J 7	6132A	CONDENSER PACKAGE ('81 MODEL)						
2 - L 7	6132AB	CONDENSER PACKAGE ('82 MODEL)						

5560A-1 DASHBOARD & RELATED

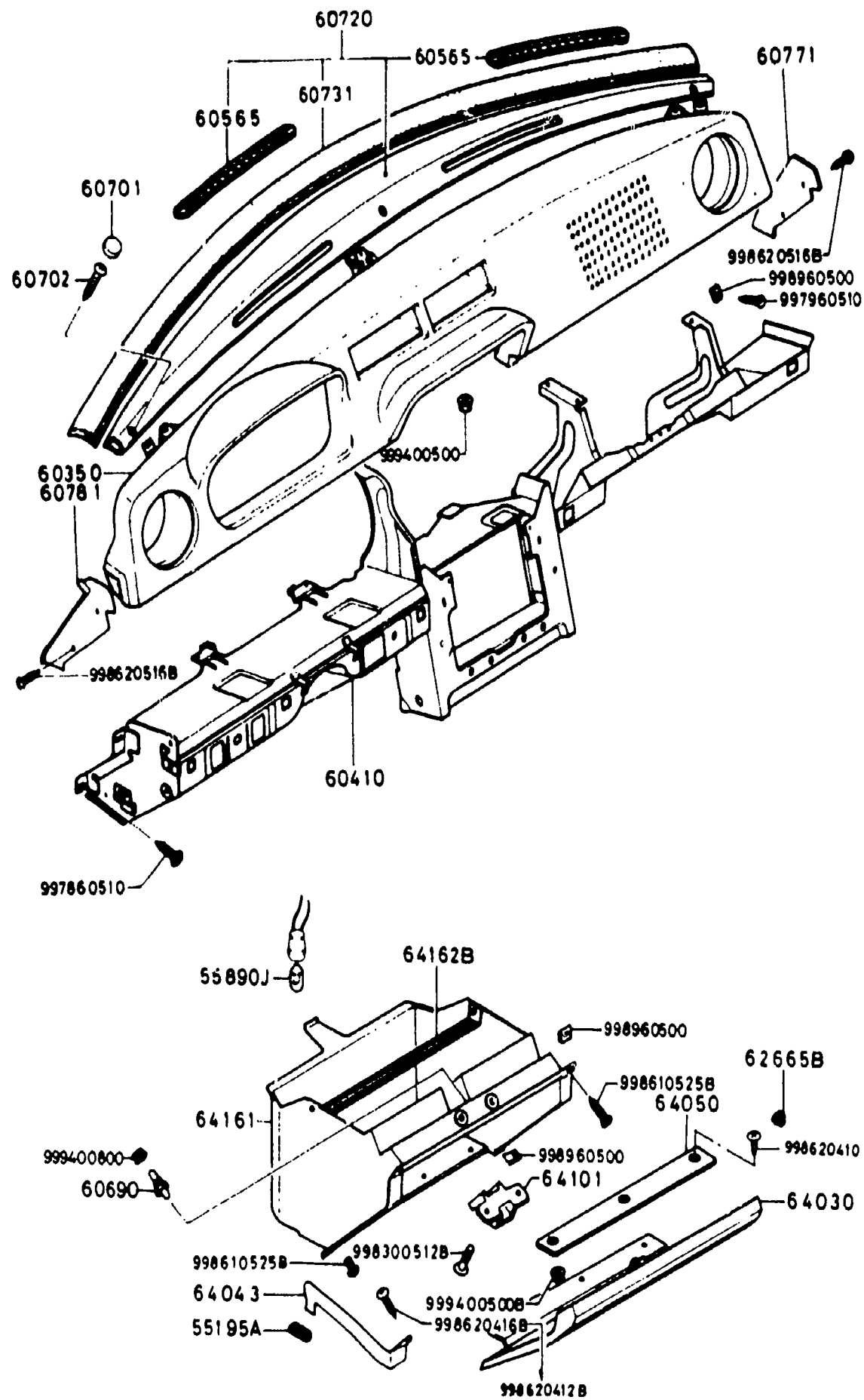

ITEM NO.	D-CODE	DESCRIPTION	PART NO.	QTY	MODEL/DESCRIPTION	REMARKS
	55 195A	RUBBER, STOPPER	0275-53-195A	1		
	55 890J	BULB	0000-11-0194	1	(A12V 3.4W)	
	60 350	PAD, CRUSH	FA01-60-350A	1	'81 MODEL	FB331 ..500001-529438
		BLACK	00			
		RED	10			
		BROWN	70			
						FB331 ..511442-529438
			FA01-60-350B	1		FB331 ..529439-
		BLACK	00			
		RED	10			
		TAN	29			FB331 ..600001-700000
		BROWN	70			
		DARK TAN	81			FB331 ..700001-
	60 410	FRAME, INSTRUMENT PANEL	FA01-60-400F	1		
	60 565	GRILLE	8341-60-713	2		
		BLACK	01			
		RED	10			
		BROWN	28			
		TAN	29			FB331 ..600001-700000
		DARK TAN	81			FB331 ..700001-
	60 690	SWITCH, GLOVE TRAY	0305-60-690	1	(FOR GLOVE BOX LAMP)	
	60 701	CAP, GARNISH	8871-60-701	3		
		BLACK	00			
		RED	11			
		BROWN	28			
		TAN	71			FB331 ..600001-700000
		DARK TAN	75			FB331 ..700001-
	60 702	SCREW, GARNISH	8871-60-702	3		
	60 720	GARNISH, UPPER	8341-60-710A	1		
		BLACK	00			
		BLACK	01			
		RED	10			
		BROWN	28			
		TAN	29			FB331 ..600001-700000
		DARK TAN	81			FB331 ..700001-
	60 731	RUBBER, SEAMING	8562-60-712	1		
	60 771	GARNISH (P)	FA01-55-330A	1		
		BLACK	00			
		RED	10			
		TAN	29			FB331 ..600001-700000

5560A-2 DASHBOARD & RELATED

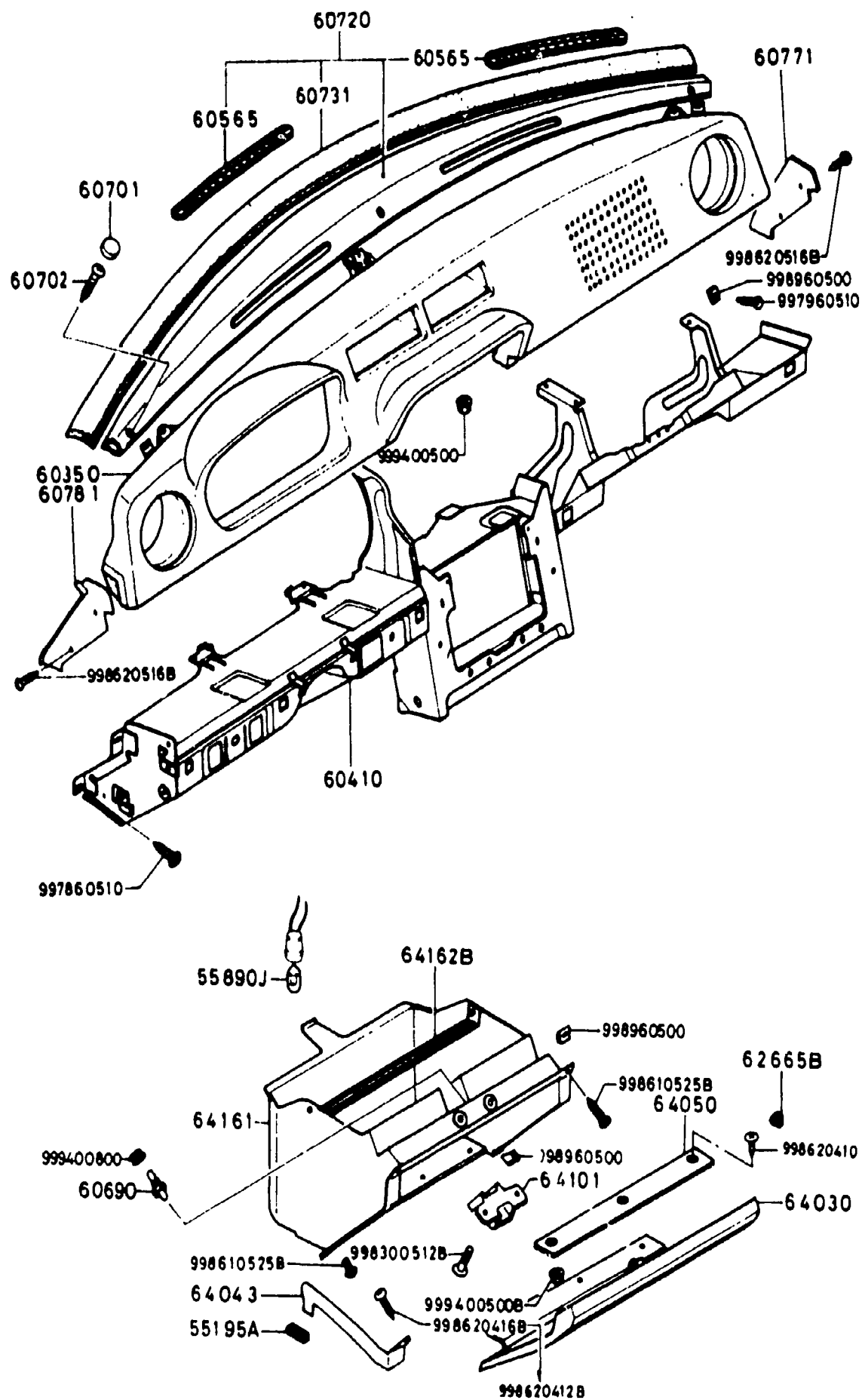

ITEM NO.	D-CODE	DESCRIPTION	PART NO.	QTY	MODEL/DESCRIPTION	REMARKS
60 771	(CONT'D)	BROWN	70			
		DARK TAN	81			FB331 ..700001-
60 781		GARNISH (L)	FA01-55-340A	1		
		BLACK	00			
		RED	10			
		TAN	29			FB331 ..600001-700000
		BROWN	70			
		DARK TAN	81			FB331 ..700001-
62 665B		RUBBER, CUSHION	0633-62-879	2	'81 & '82 MODELS	FB331 ..500001-608442
			0259-58-612	2	'82 & '83 MODELS	FB331 ..608443-
64 030		LID, GLOVE POCKET	FA01-64-030	1		
		BLACK	00			
		RED	10			
		TAN	29			FB331 ..600001-700000
		BROWN	70			
		DARK TAN	81			FB331 ..700001-
64 043		STOPPER	8871-64-043	1		
64 050		SET PLATE, GLOVE LID	8871-64-050A	1		
64 101		STRIKER	8871-64-101	1		
64 161		TRAY, GLOVE	8871-64-161B	1		
64 162B		STAY, GLOVE TRAY	8871-64-162A	1		

5570A-1 CONSOLE

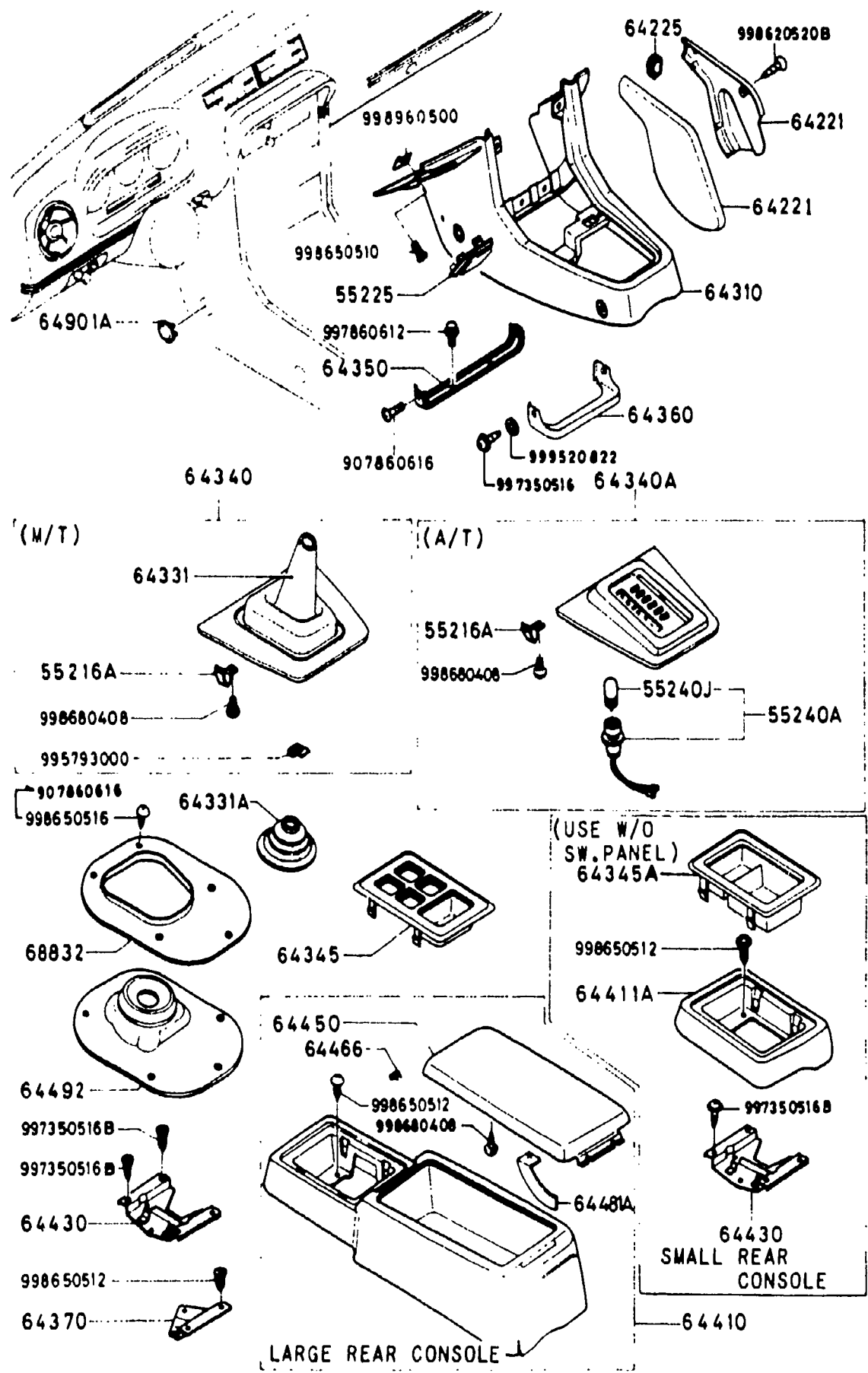

ITEM NO.	D-CODE	DESCRIPTION	PART NO.	QTY	MODEL/DESCRIPTION	REMARKS
55 216A		SPRING, BOOT PANEL	8871-55-216	2		
55 225		COVER, SWITCH HOLE	FA01-55-225	1	(W/O REM. CONTROL) S MODEL	
55 240A		BULB & SOCKET	0305-66-580A	1	A/T	
			<A> 1840-55-240	1		
55 240J		BULB	0000-11-0194	1	(A12V 3.4W) A/T	
64 221		COVER (R), BRAKE	FA01-64-221	1		
		BLACK	00			
		RED	10			
		TAN	29			FB331 ..600001-700000
		BROWN	70			
		DARK TAN	81			FB331 ..700001-
		COVER (L), BRAKE	FA01-64-222	1		
		BLACK	00			
		RED	10			
		TAN	29			FB331 ..600001-700000
		BROWN	70			
		DARK TAN	81			FB331 ..700001-
64 225		RING, BRAKE COVER	FA01-64-225	1		
64 310		CONSOLE, FRONT	FA01-64-320B	1		
		BLACK	00			
		RED	10			
		TAN	29			
		BROWN	70			
		DARK TAN	81			
64 331		BOOT, CHANGE	FA01-64-351A	1	M/T	
		BLACK	01	1		
64 331A		BOOT	FA01-64-494	1	M/T	
64 340		PLATE, UPPER	FA01-64-350A	1	M/T	
		SILVER METALLIC/BLACK	01			
64 340A		INDICATOR	FA03-64-350	1	A/T	
		SILVER METALLIC	01			
64 345		PANEL, SWITCH	FA01-64-451	1		
		SILVER METALLIC	01			
64 345A		BOX, COIN	FA02-64-451	1	(USE W/O SWITCH PANEL)	
		SILVER METALLIC	01			
64 350		BRACKET, FRONT	8871-64-370A	1		
64 360		BRACKET, CENTER	FA01-64-381	1		
64 370		BRACKET, REAR	8871-64-415	1	(USE W/ LARGE RR. CONSOLE)	

5570A-2 CONSOLE

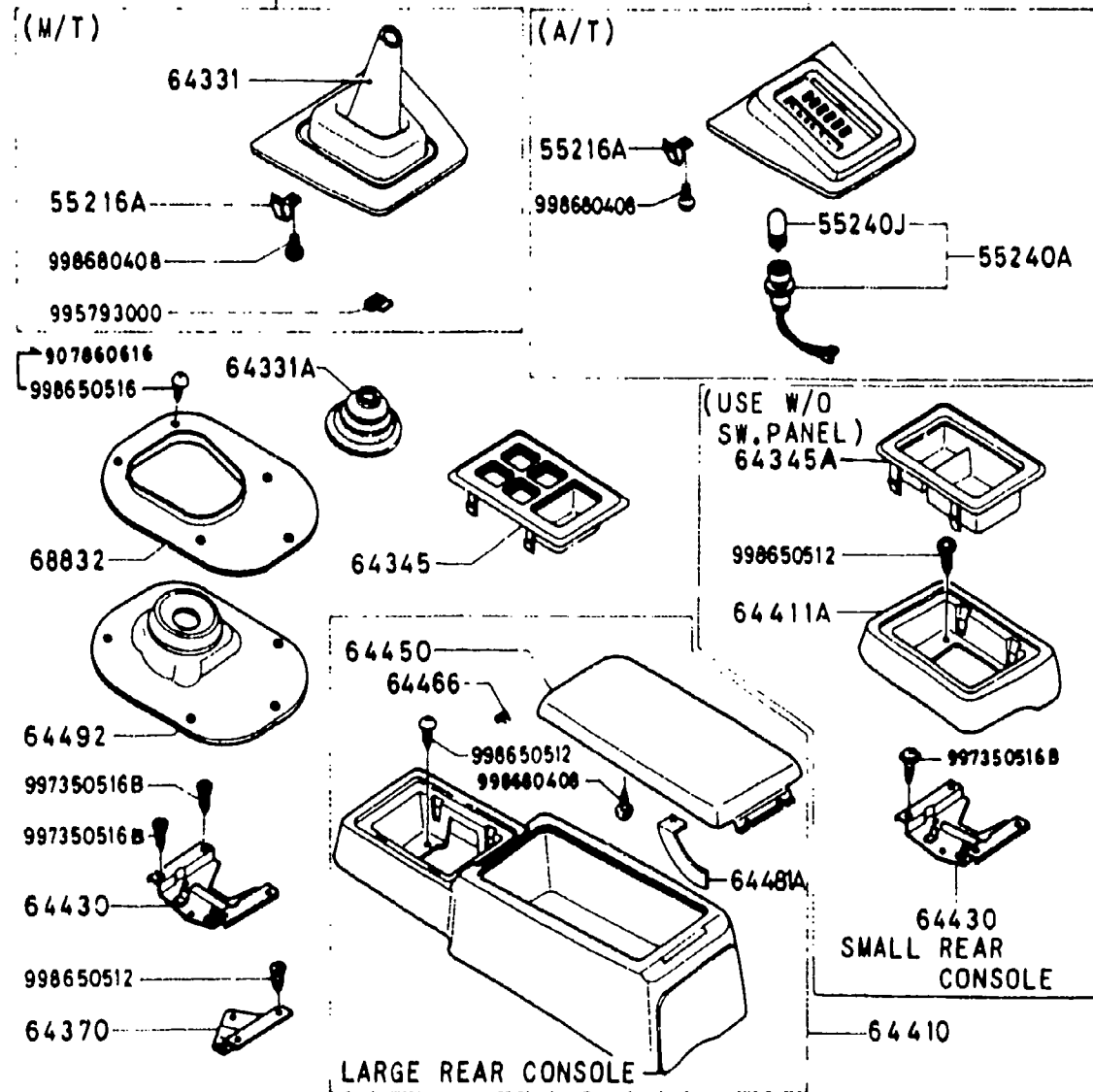
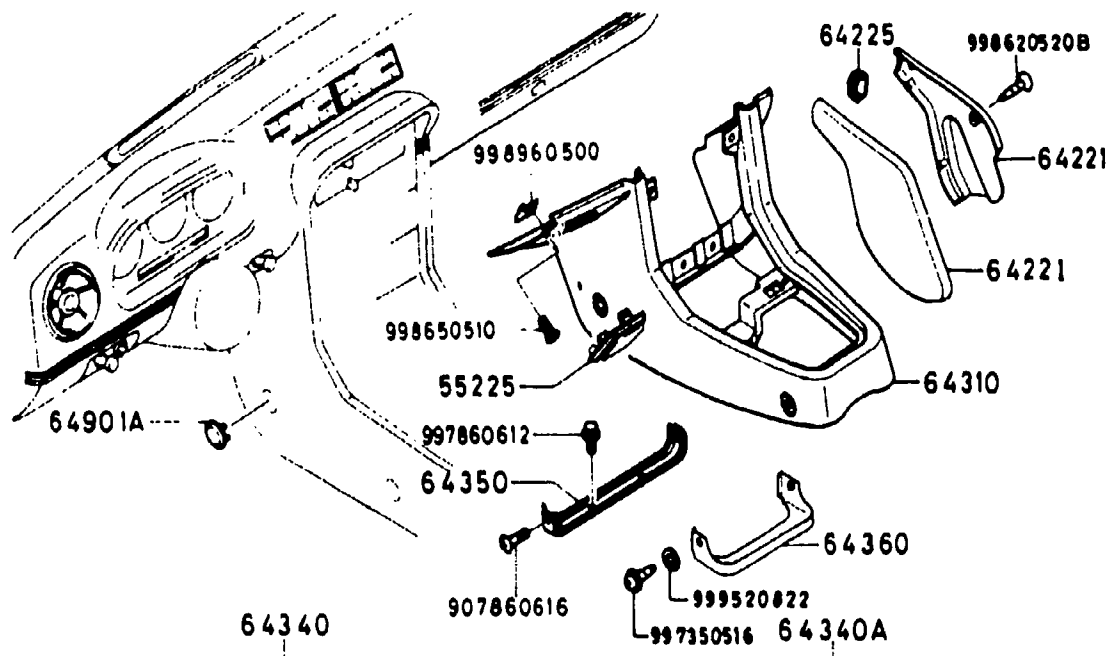

ITEM NO.	D-CODE	DESCRIPTION	PART NO.	QTY	MODEL/DESCRIPTION	REMARKS
64 410		CONSOLE, REAR	FA01-64-410C	1		
		BLACK	00			
		RED	10			
		TAN	29			
		BROWN	70			
		DARK TAN	81			
64 411A		CASE, SWITCH PANEL	FA02-64-411	1	(SMALL TYPE)	
		BLACK	00			
		RED	10			
		TAN	29			FB331 ..600001-700000
		BROWN	70			
		DARK TAN	81			FB331 ..700001-
64 430		BRACKET, CENTER-REAR	8871-64-430A	1	(USE W/ SMALL RR. CONSOLE) S MODEL	
			FA01-64-430	1	(USE W/ LARGE RR. CONSOLE) GS & GSL MODELS	
64 450		LID, CONSOLE	FA01-64-420B	1	(USE W/ LARGE TYPE CONSOLE)	
		BLACK	00			
		RED	10			
		TAN	29			
		BROWN	70			
		DARK TAN	81			
64 466		SPRING, HINGE	FA01-64-413A	1		
64 481A		STOPPER, CONSOLE LID	8871-64-412	1		
64 492		INSULATOR	FA01-64-492	1	M/T	
64 901A		CAP, FRONT CONSOLE	8871-64-901	4		
		BLACK	00			
		RED	11			
		BROWN	70			
		TAN	71			FB331 .. 00001-700000
		DARK TAN	75			FB331 ..700001-
68 832		SEAT, BOOT	FA01-64-491	1	M/T	

5580A-1 VENTILATOR

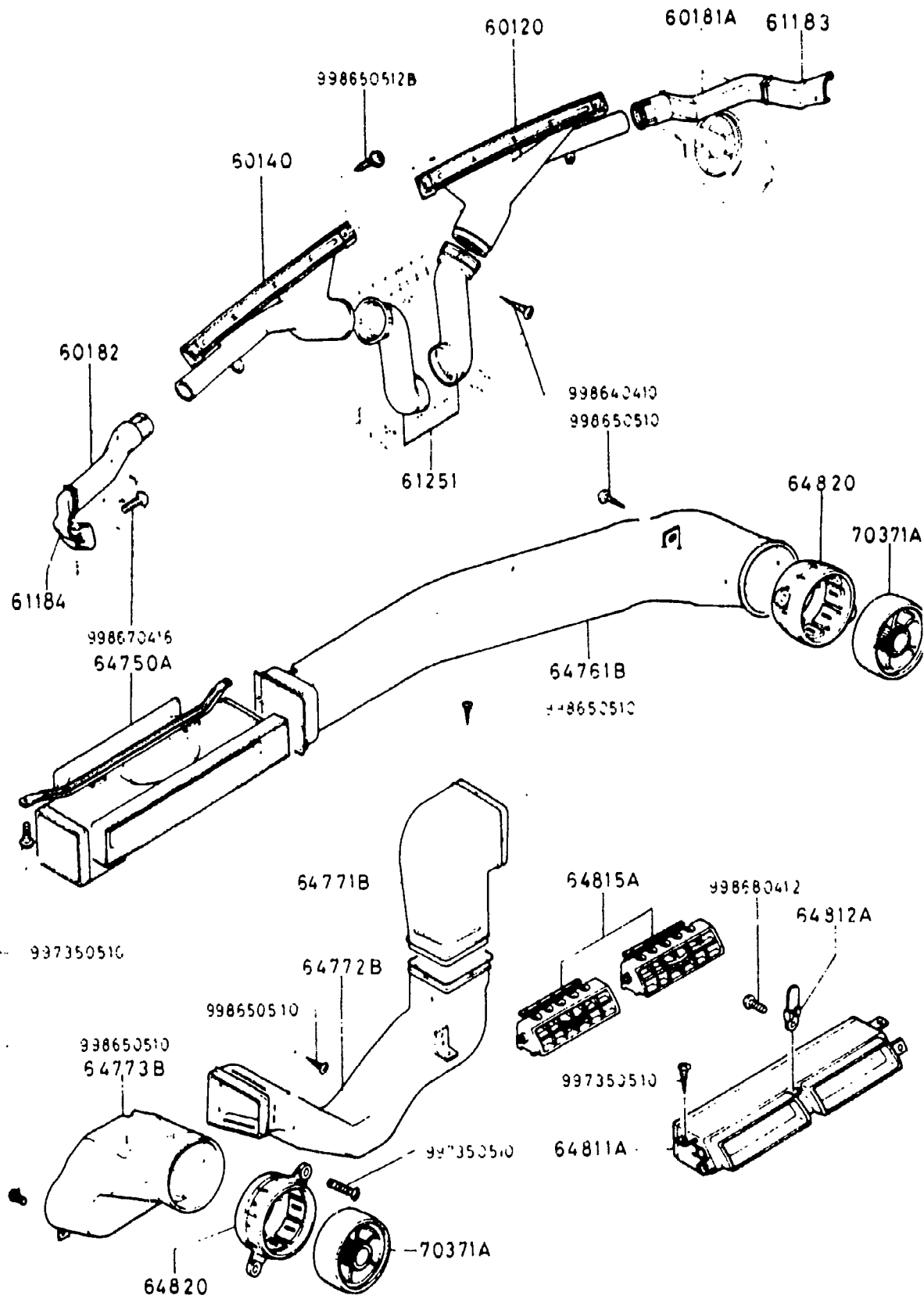

ITEM NO.	D-CODE	DESCRIPTION	PART NO.	QTY	MODEL/DESCRIPTION	REMARKS
	60 120	NOZZLE (R), DEFROSTER	8871-60-121	1		
	60 140	NOZZLE (L), DEFROSTER	8871-60-141	1		
	60 181A	DUCT (R), SIDE DEMISTER	8871-61-181	1		
	60 182	DUCT (L), SIDE DEMISTER	8871-61-182	1		
	61 183	DUCT (R), SIDE DEMISTER	8871-61-183A	1		
	61 184	DUCT (L), SIDE DEMISTER	8871-61-184A	1		
	61 251	HOSE, DEFROSTER	8871-61-251A	2		
	64 750A	DUCT, CENTER	8871-64-750A	1		
	64 761B	DUCT (R)	8871-64-761	1		
	64 771B	DUCT NO. 1 (L)	8871-64-771A	1		
	64 772B	DUCT NO. 2 (L)	8871-64-780B	1		
	64 773B	DUCT NO. 3 (L)	8871-64-773	1		
	64 811A	GUIDE, CENTER LOUVER	8871-64-811A	1		
	64 812A	HOLDER, CENTER LOUVER	8871-64-812	1		
	64 815A	LOUVER, CENTER	8570-64-815B	2		
	64 820	GUIDE, LOUVER	8871-64-820	2		
	70 371A	LOUVER, VENTILATOR	8341-64-825	2		

5700A-1 SEATS ('81 & '82) MODELS

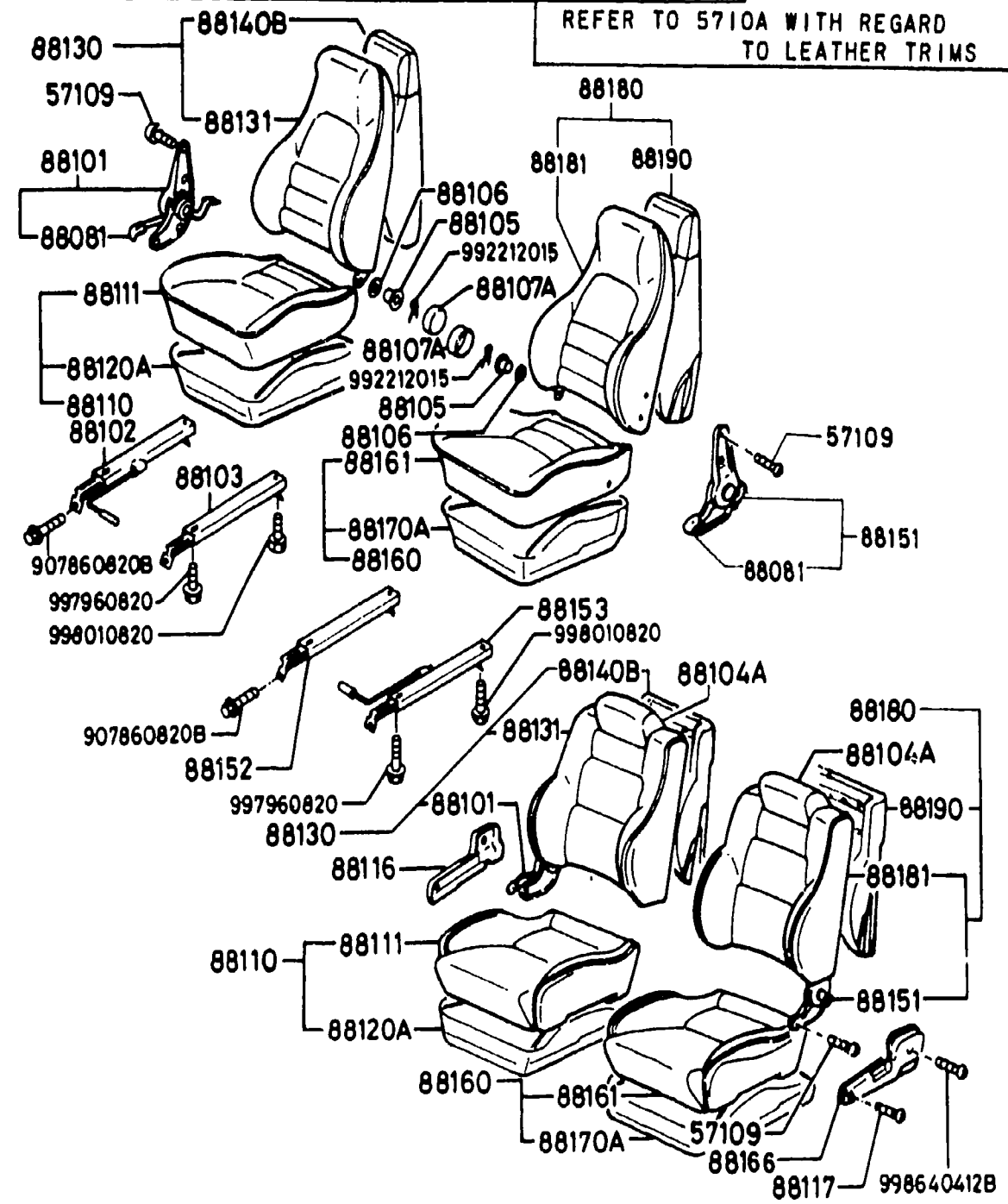
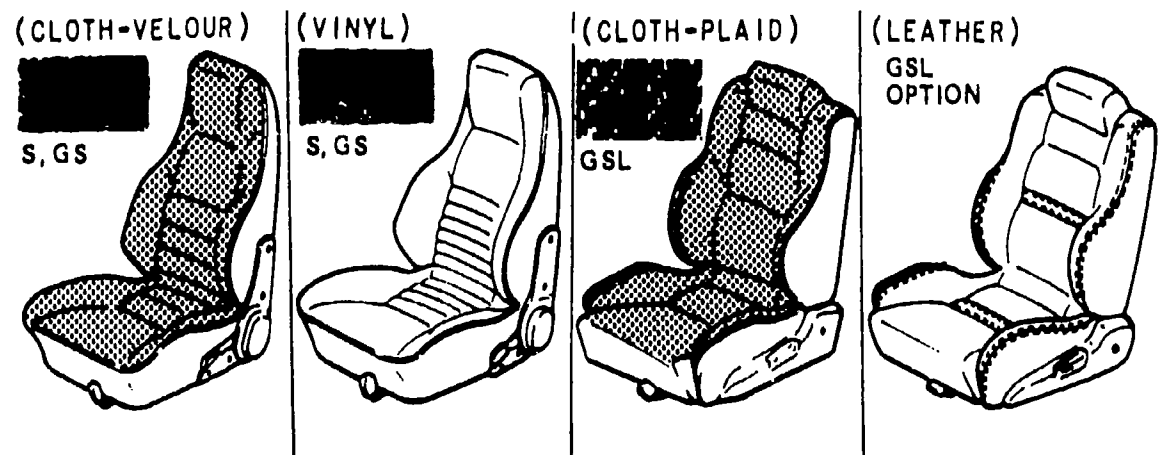

REFER TO 5710A WITH REGARD TO LEATHER TRIMS

ITEM NO.	D-CODE	DESCRIPTION	PART NO.	QTY	MODEL/DESCRIPTION	REMARKS
57 109		SCREW, KNUCKLE	2155-57-109	8		
88 081		KNOB, KNUCKLE	0305-57-081	2		(USE W/O KNUCKLE COVER)
		BLACK	00			
88 101		KNUCKLE (R), RECLINING	8183-88-101	1		(USE W/ KNUCKLE COVER)
			8531-88-101	1		(USE W/O KNUCKLE COVER)
88 102		ADJUSTER NO. 1	8183-88-102	1		
88 103		ADJUSTER NO. 2	F005-88-103	1		
88 104A		RESTRAINT, HEAD	FA09-88-104	2		(FOR CLOTH-PLAID) GSL MODEL
		BLACK	00			
		RED	10			
		BROWN	70			
88 105		BUSHING	8531-88-106	2		
88 106		WASHER	8531-88-105	2		
88 107A		COVER, HINGE	8531-88-107	2		
88 110		CUSHION (R), FRONT SEAT	FA07-88-110	1		(CLOTH-VELOUR) S & GS MODELS
		BLACK	00			
		RED	10			
		BROWN	70			
			FA08-88-110	1		(VINYL) S & GS MODELS
		BLACK	00			
		BROWN	70			
			FA09-88-110	1		(CLOTH-PLAID) GSL MODEL
		BLACK	00			
		RED	10			
		BROWN	70			
88 111		TRIM (R), SEAT CUSHION	FA07-88-111	1		(CLOTH-VELOUR) S & GS MODELS
		BLACK	00			
		RED	10			
		BROWN	70			
			FA08-88-111	1		(VINYL) S & GS MODELS
		BLACK	00			
		BROWN	70			
			FA09-88-111	1		(CLOTH-PLAID) GSL MODEL
		BLACK	00			

5700A-2 SEATS ('81 & '82) MODELS

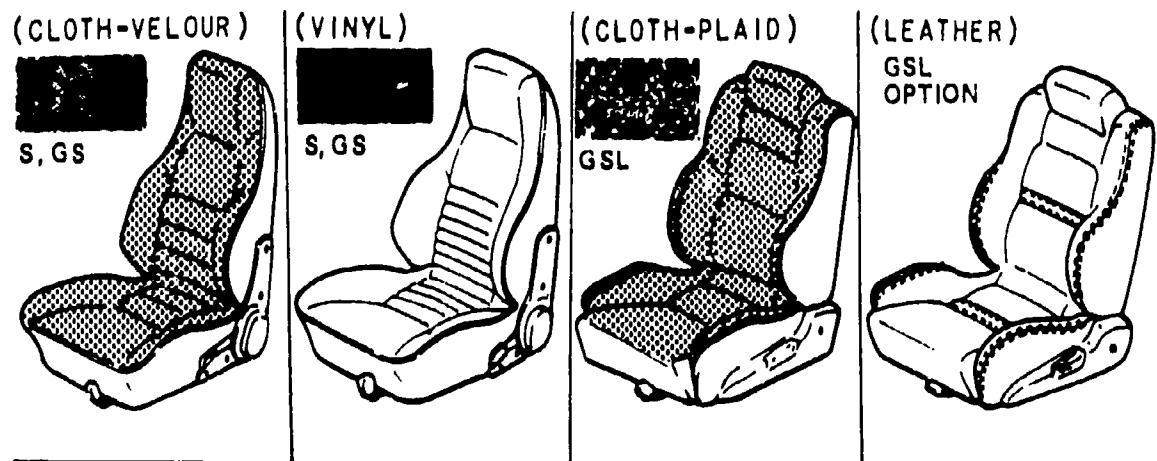

REFER TO 5710A WITH REGARD TO LEATHER TRIMS

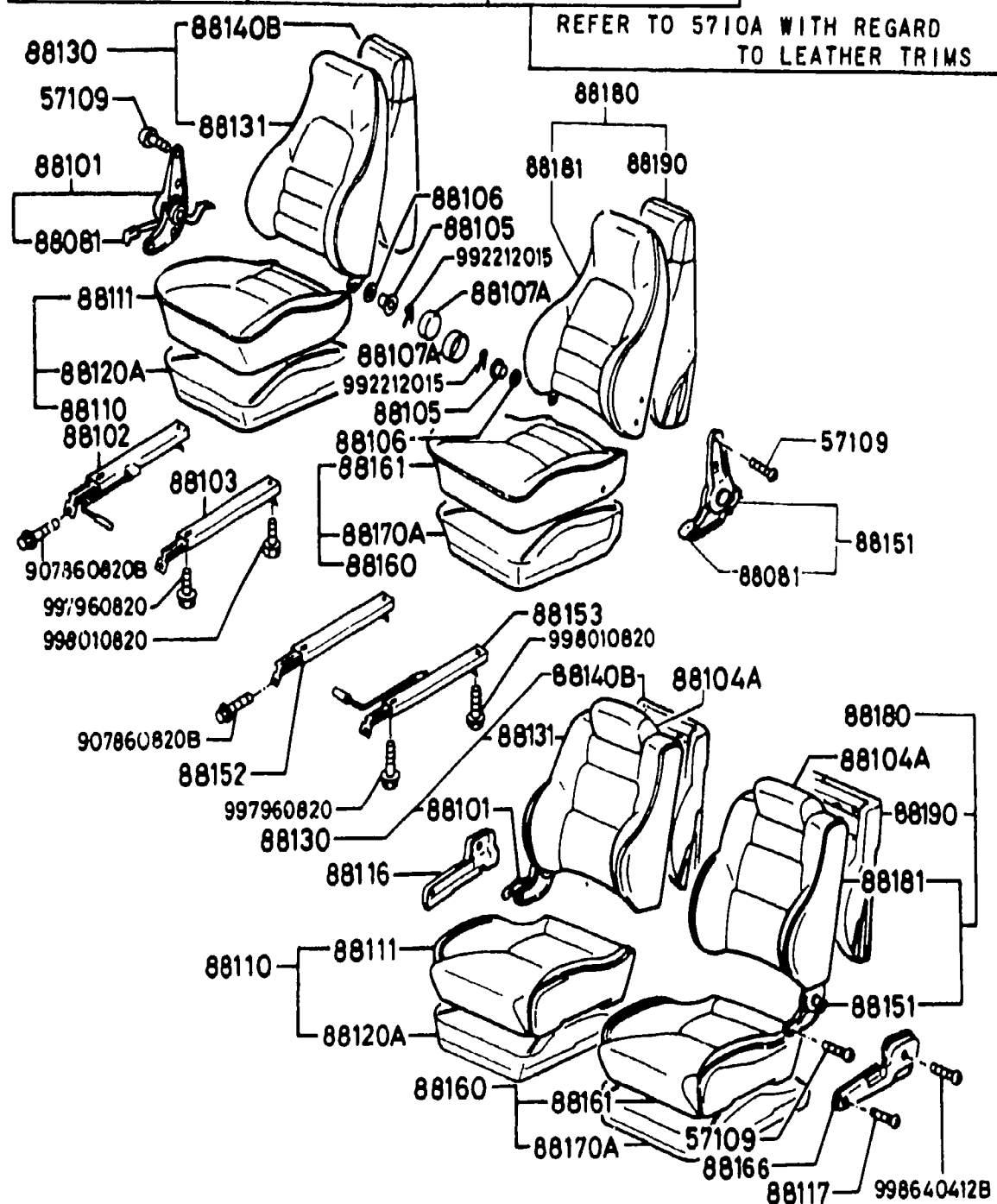

ITEM NO.	D-CODE	DESCRIPTION	PART NO.	QTY	MODEL/DESCRIPTION	REMARKS
88 111 (CONT'D)		RED	10			
		BROWN	70			
88 116		COVER (R), KNUCKLE	F007-88-120	1	(FOR NON HIGH BACK TYPE) '81 MODEL	
		BLACK	00			
		RED	10			
		BROWN	70			
			8183-88-120	1	(FOR NON HIGH BACK TYPE) '82 MODEL	
		BLACK	00			
		RED	10			
		BROWN	70			
88 117		SCREW, KNUCKLE	1243-88-117	2	(USE W/ KNUCKLE COVER)	
88 120A		FRAME & PAD (R), CUSHION	FA02-88-120	1	(FOR NON HIGH BACK TYPE)	
			8871-88-120A	1	(FOR HIGH BACK TYPE)	
88 130		BACK (R), FRONT SEAT	FA07-88-130	1	(CLOTH-VELOUR) S & GS MODELS	
		BLACK	00			
		RED	10			
		BROWN	70			
			FA08-88-130	1	(VINYL) S & GS MODELS	
		BLACK	00			
		BROWN	70			
			FA09-88-130	1	(CLOTH-PLAID) GSL MODEL	
		BLACK	00			
		RED	10			
		BROWN	70			
88 131		TRIM (R), SEAT BACK	FA07-88-131	1	(CLOTH-VELOUR) S & GS MODELS	
		BLACK	00			
		RED	10			
		BROWN	70			
			FA08-88-131	1	(VINYL) S & GS MODELS	
		BLACK	00			
		BROWN	70			
			FA09-88-131	1	(CLOTH-PLAID) GSL MODEL	

5700A-3 SEATS ('81 & '82) MODELS

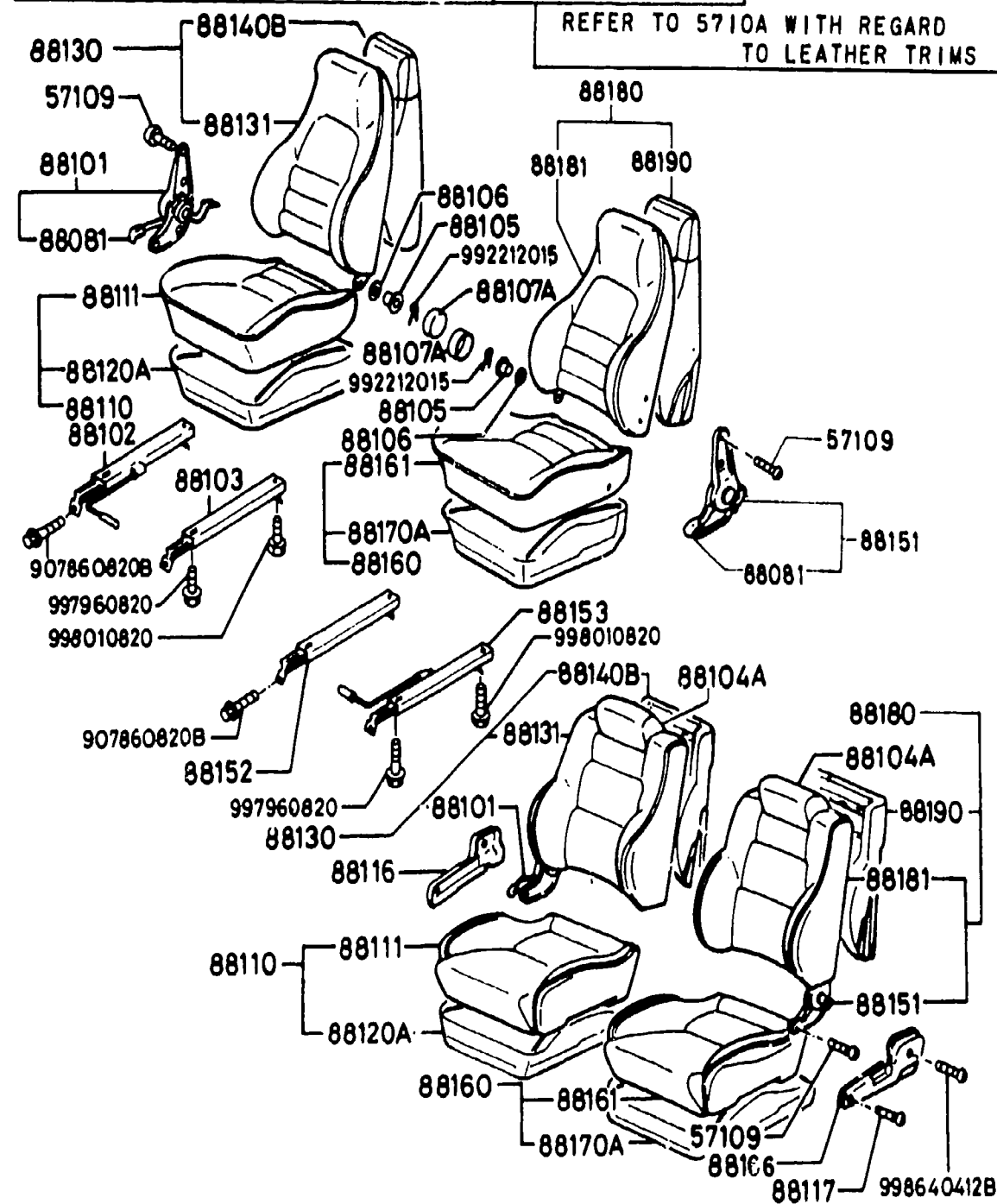
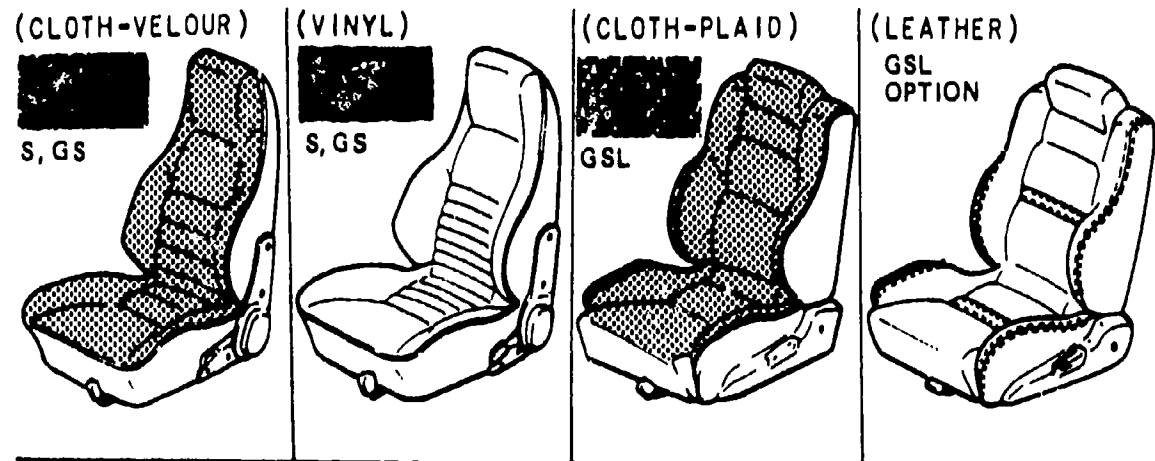

ITEM NO.	D-CODE	DESCRIPTION	PART NO.	QTY	MODEL/DESCRIPTION	REMARKS
88 131 (CONT'D)		BLACK	00			
		RED	10			
		BROWN	70			
88 140B		FRAME & PAD (R), BACK	FA02-88-140	1	(FOR NON HIGH BACK TYPE)	
			8871-88-140	1	(FOR HIGH BACK TYPE)	
88 151		KNUCKLE (L), RECLINING	FA09-88-151	1	(USE W/ KNUCKLE COVER)	
			8532-88-151	1	(USE W/O KNUCKLE COVER)	
88 152		ADJUSTER NO. 3	F005-88-152	1		
88 153		ADJUSTER NO. 4	FA07-88-153	1		
88 160		CUSHION (L), FRONT SEAT	FA07-88-160	1	(CLOTH-VELOUR) S & GS MODELS	
		BLACK	00			
		RED	10			
		BROWN	70			
			FA08-88-160	1	(VINYL) S & GS MODELS	
		BLACK	00			
		BROWN	70			
			FA09-88-160	1	(CLOTH-PLAID) GSL MODEL	
		BLACK	00			
		RED	10			
		BROWN	70			
88 161		TRIM (L), SEAT CUSHION	FA07-88-161	1	(CLOTH-VELOUR) S & GS MODELS	
		BLACK	00			
		RED	10			
		BROWN	70			
			FA08-88-161	1	(VINYL) S & GS MODELS	
		BLACK	00			
		BROWN	70			
			FA09-88-161	1	(CLOTH-PLAID) GSL MODEL	
		BLACK	00			
		RED	10			
		BROWN	70			
88 166		COVER (L), KNUCKLE	F007-88-170	1	(FOR NON HIGH BACK TYPE) '81 MODEL	
		BLACK	00			

5700A-4 SEATS ('81 & '82) MODELS

(CLOTH-VELOUR)

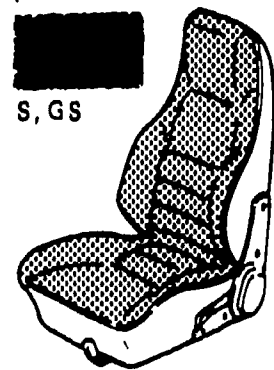

(VINYL)

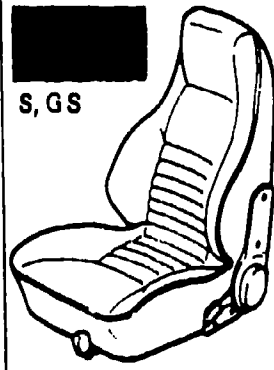

(CLOTH-PLAID)

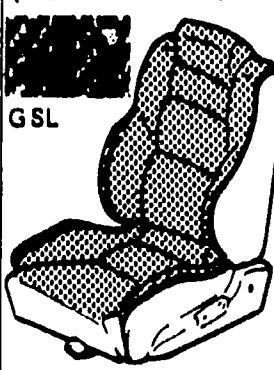

(LEATHER)
GSL
OPTION

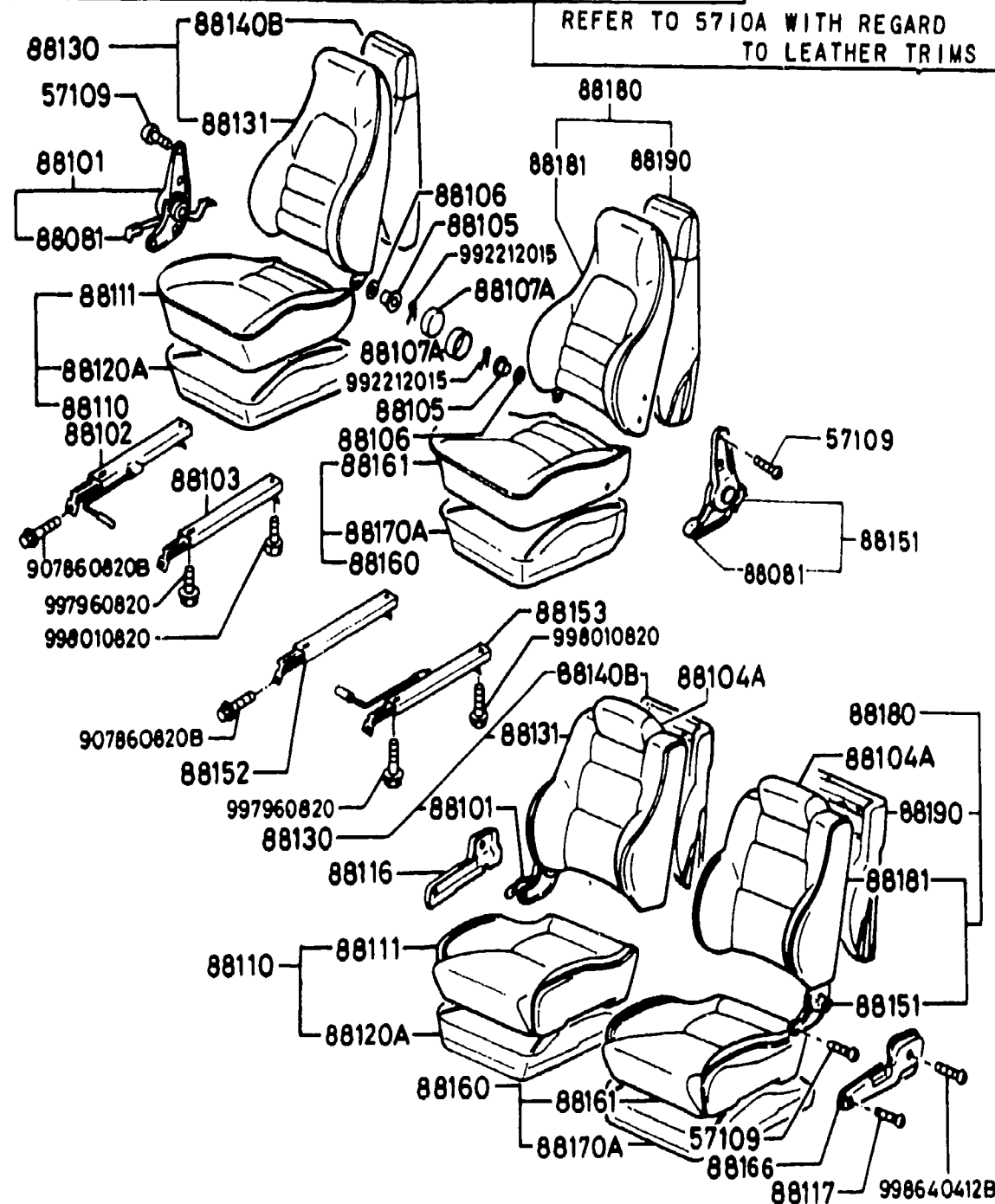
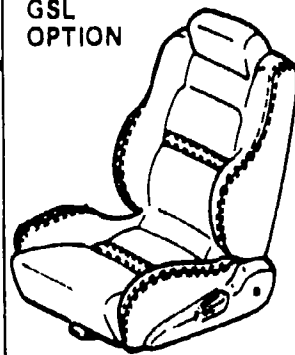

ITEM NO.	D-CODE	DESCRIPTION	PART NO.	QTY	MODEL/DESCRIPTION	REMARKS
88 166 (CONT'D)		RED	10			
		BROWN	70			
			8183-88-170	1	(FOR NON HIGH BACK TYPE)	'82 MODEL
		BLACK	00			
		RED	10			
	BROWN	70				
88 170A		FRAME & PAD (L), CUSHION	FA02-88-170	1	(FOR NON HIGH BACK TYPE)	
			8871-88-170	1	(FOR HIGH BACK TYPE)	
88 180		BACK (L), FRONT SEAT	FA07-88-180	1	(CLOTH-VELOUR)	S & GS MODELS
		BLACK	00			
		RED	10			
		BROWN	70			
			FA08-88-180	1	(VINYL)	S & GS MODELS
		BLACK	00			
		BROWN	70			
			FA09-88-180	1	(CLOTH-PLAID)	GSL MODEL
		BLACK	00			
		RED	10			
		BROWN	70			
88 181		TRIM (L), SEAT BACK	FA07-88-131	1	(CLOTH-VELOUR)	S & GS MODELS
		BLACK	00			
		RED	10			
		BROWN	70			
			FA08-88-131	1	(VINYL)	S & GS MODELS
		BLACK	00			
		BROWN	70			
			FA09-88-181	1	(CLOTH-PLAID)	GSL MODEL
		BLACK	00			
		RED	10			
		BROWN	70			
88 190		FRAME & PAD (L), BACK	FA02-88-190	1	(FOR NON HIGH BACK TYPE)	
			8871-88-190	1	(FOR HIGH BACK TYPE)	

SECTION INDEX -- BODY

STARTING LOCATION	SECT. NO.	SECTION NAME	STARTING LOCATION	SECT. NO.	SECTION NAME	STARTING LOCATION	SECT. NO.	SECTION NAME
2 - C 3	0900A	KEY SETS	2 - C 8	6132AC	CONDENSER PACKAGE ('83 MODEL)	2 - H11	6870A	SERVICE TOOLS
2 - D 3	5000A	FRONT BUMPER	2 - E 8	6142A	COMPRESSOR MOUNTING KIT, COMPRESSOR/CLUTCH ASSEMBLY & REPAIR PARTS ('81 MODEL)	2 - I11	6900A	VISOR, ASSIST HANDLE & MIRRORS
2 - E 3	5005A	RADIATOR GRILLE	2 - F 8	6142AB	COMPRESSOR MOUNTING KIT, COMPRESSOR/CLUTCH ASSEMBLY & REPAIR PARTS ('82 MODEL)	2 - I11	6930A	CAUTION PLATES
2 - F 3	5010A	REAR BUMPER	2 - G 8	6142AC	COMPRESSOR MOUNTING KIT, COMPRESSOR/CLUTCH ASSEMBLY & REPAIR PARTS ('83 MODEL)			
2 - G 3	5030A	WINDOW MOULDINGS	2 - H 8	6152A	EVAPORATOR PACKAGE ('81 MODEL)			
2 - H 3	5040A	BODY MOULDINGS	2 - I 8	6152AB	EVAPORATOR PACKAGE ('82 MODEL)			
2 - I 3	5060A	SIDE PROTECTORS	2 - J 8	6152AC	EVAPORATOR PACKAGE ('83 MODEL)			
2 - J 3	5100A	HEAD LAMPS	2 - K 8	6230A	BACK DOOR MECHANISM			
2 - K 3	5103A	HEAD LAMP RETRACTORS	2 - L 8	6300A	WINDOW GLASSES			
2 - L 3	5105A	FRONT COMBINATION & SIDE TURN LAMPS	2 - M 8	6330A	SUNROOF (GSI)			
2 - M 3	5110A	REAR COMBINATION LAMPS	2 - N 8	6600A	SWITCH & RELAY (ENGINE & TRANSMISSION)			
2 - N 3	5120A	LICENSE & REAR SIDE TURN LAMPS	2 - C 9	6610A	DASHBOARD SWITCHES (MANUAL OPERATING)			
2 - C 4	5125A	INTERIOR LAMPS (GS & GSI)	2 - D 9	6611A	COMBINATION SWITCH			
2 - D 4	5170A	ORNAMENTS	2 - E 9	6615A	POWER WINDOW SWITCH			
2 - E 4	5180A	COWL & EXTRACTOR GRILLES	2 - F 9	6620A	DOOR, PARKING LAMP & KICK DOWN SWITCH			
2 - F 4	5230A	HOOD	2 - G 9	6630A	RELAY (BODY)			
2 - G 4	5310A	BODY PANELS (FRONT)	2 - H 9	6635A	HORN			
2 - I 4	5340A	BODY PANELS (SIDE & ROOF)	2 - I 9	6640A	AUTO CRUISE CONTROL			
2 - J 4	5360A	BODY PANELS (FLOOR)	2 - J 9	6680A	AUDIO SYSTEM			
2 - K 4	5370A	FLOOR ATTACHMENTS	2 - M 9	6700A	WIRE HARNESS (FRONT & REAR)			
2 - L 4	5500A	DASHBOARD EQUIPMENT	2 - N 9	6701A	WIRE HARNESS (ENGINE & TRANSMISSION)			
2 - N 4	5540A	METERS	2 - C10	6702A	WIRE HARNESS (DASHBOARD)			
2 - C 5	5560A	DASHBOARD & RELATED	2 - D10	6703A	WIRE HARNESS (DOOR, FLOOR & CEILING)			
2 - E 5	5570A	CONSOLE	2 - E10	6704A	WIRE HARNESS CLAMPS			
2 - G 5	5580A	VENTILATOR	2 - F10	6720A	WINDSHIELD WASHER			
2 - H 5	5700A	SEATS ('81 & '82) MODELS	2 - G10	6730A	WINDSHIELD WIPER			
2 - C 6	5700AA	SEATS ('83 MODEL)	2 - H10	6740A	WIPER MOTOR (COMPONENTS ONLY)			
2 - H 6	5790A	SEAT BELTS	2 - I10	6750A	REAR WINDOW WIPER & WASHER			
2 - J 6	5800A	FRONT DOOR	2 - J10	6760A	REAR WINDOW WIPER MOTOR (COMPONENTS ONLY)			
2 - K 6	5830A	FRONT DOOR MECHANISM	2 - K10	6800A	CEILING TRIM			
2 - C 7	5840A	FRONT DOOR TRIM & RELATED PARTS	2 - C11	6840A	TRIM & SCUFF PLATE			
2 - F 7	6100A	HEATER	2 - F11	6860A	FLOOR MATS & PADS			
2 - G 7	6110A	HEATER UNIT						
2 - H 7	6115A	HEATER CONTROLS						
2 - I 7	6120A	HEATER BLOWER						
2 - J 7	6132A	CONDENSER PACKAGE ('81 MODEL)						
2 - L 7	6132AB	CONDENSER PACKAGE ('82 MODEL)						

5700AA-1 SEATS ('83 MODEL)

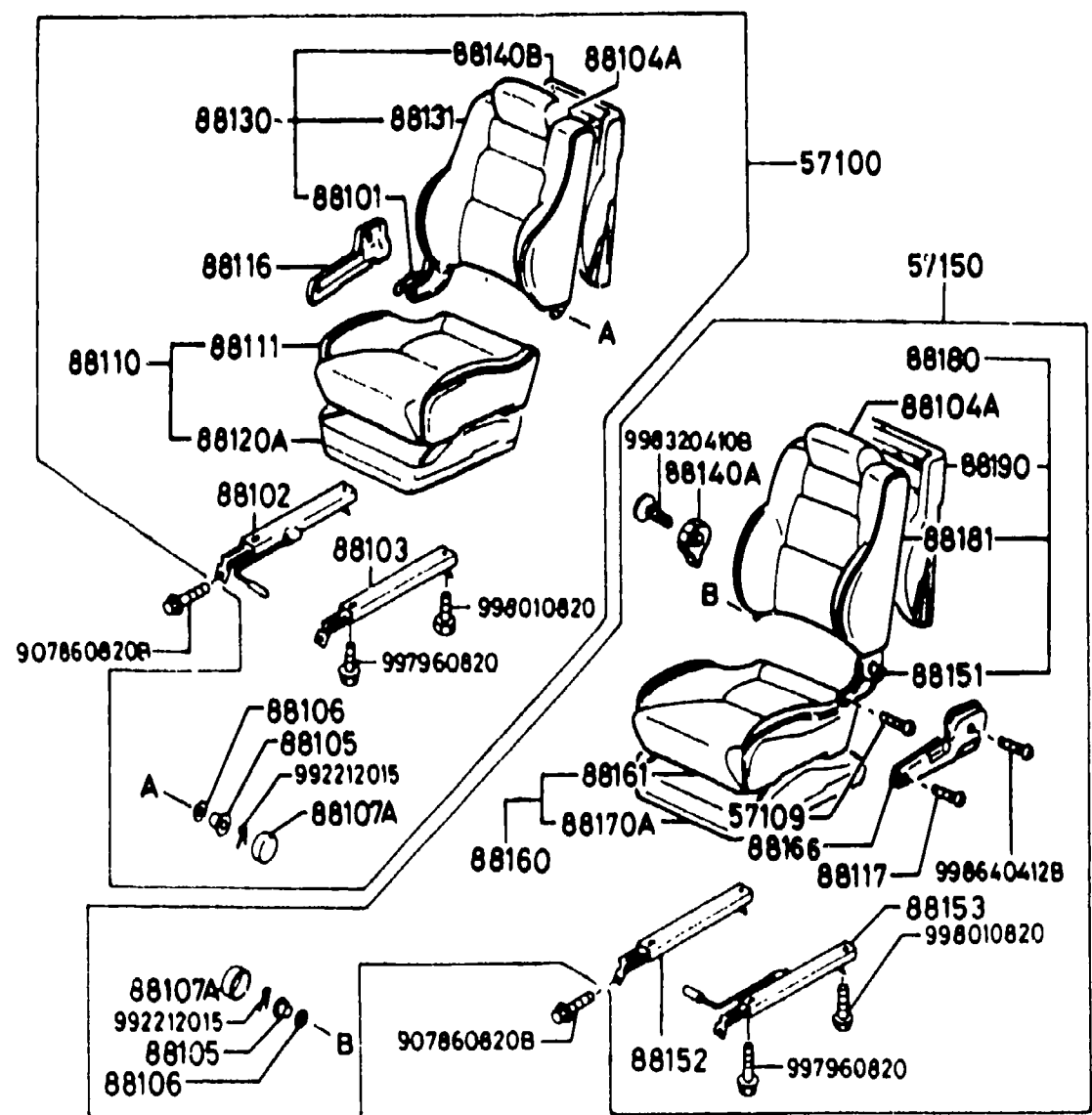
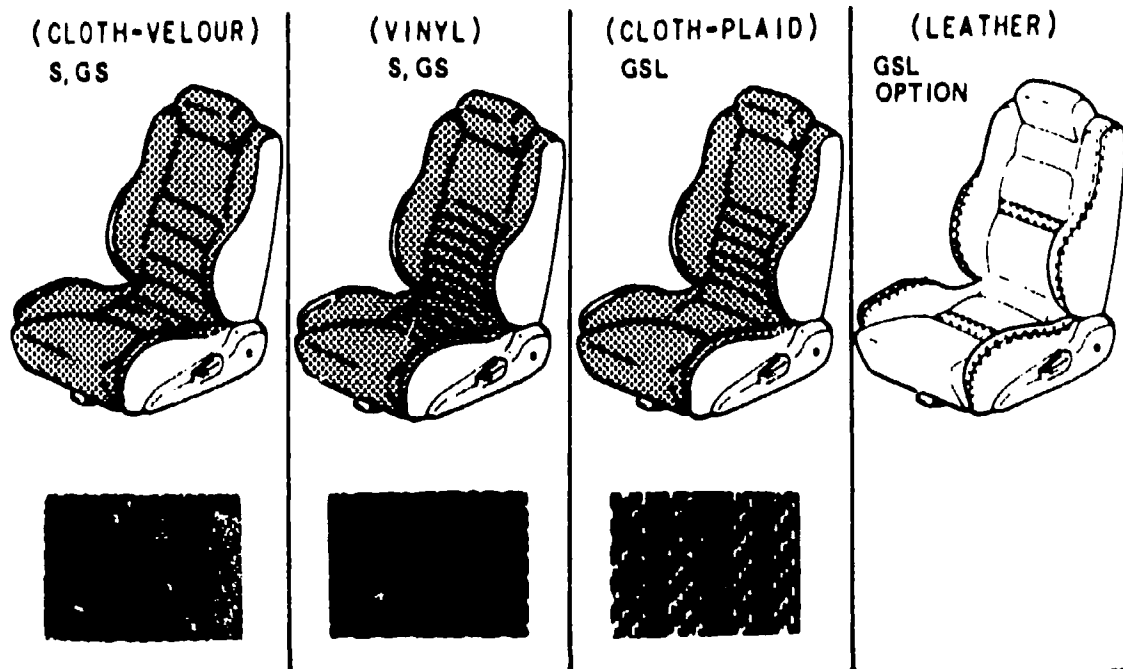

ITEM NO.	D-CODE	DESCRIPTION	PART NO.	QTY	MODEL/DESCRIPTION	REMARKS
	57 100	SEAT (R), FRONT	FA07-57-100A	1	(CLOTH-VELOUR) S & GS MODELS	
		BLACK	01			
		RED	11			
		BROWN	71			
			FA08-57-100A	1	(VINYL) S & GS MODELS	
		BLACK	01			
		BROWN	71			
			FA09-57-100A	1	(CLOTH-PLAID) GSL MODEL	
		BLACK	01			
		RED	11			
		BROWN	71			
			FA82-57-100	1	(LEATHER) GSL MODEL OPTION	
		RED	10			
		TAN	29			
		BROWN	70			
57 109		SCREW KNUCKLE	2155-57-109	8		
57 150		SEAT (L), FRONT	FA07-57-150A	1	(CLOTH-VELOUR) S & GS MODELS	
		BLACK	01			
		RED	11			
		BROWN	71			
			FA08-57-150A	1	(VINYL) S & GS MODELS	
		BLACK	01			
		BROWN	71			
			FA09-57-150A	1	(CLOTH-PLAID) S & GS MODELS	
		BLACK	01			
		RED	11			
		BROWN	71			
			FA82-57-150	1	(LEATHER) GSL MODEL OPTION	
		RED	10			
		TAN	29			
		BROWN	70			
88 101		KNUCKLE (R), RECLINING	8183-88-101	1		
88 102		ADJUSTER NO. 1	8183-88-102	1		
88 103		ADJUSTER NO. 2	F005-88-103	1		

5700AA-2 SEATS ('83 MODEL)

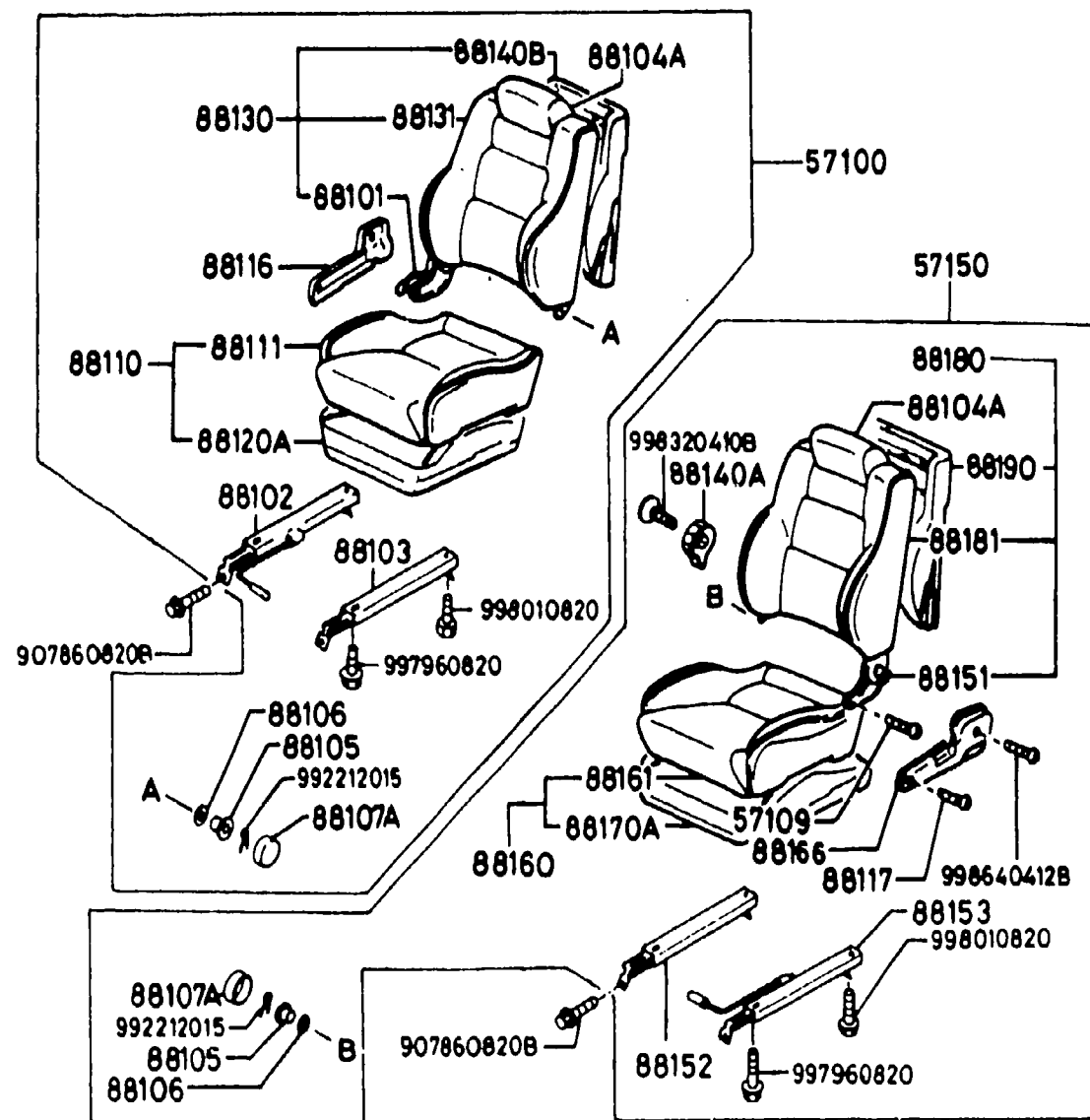
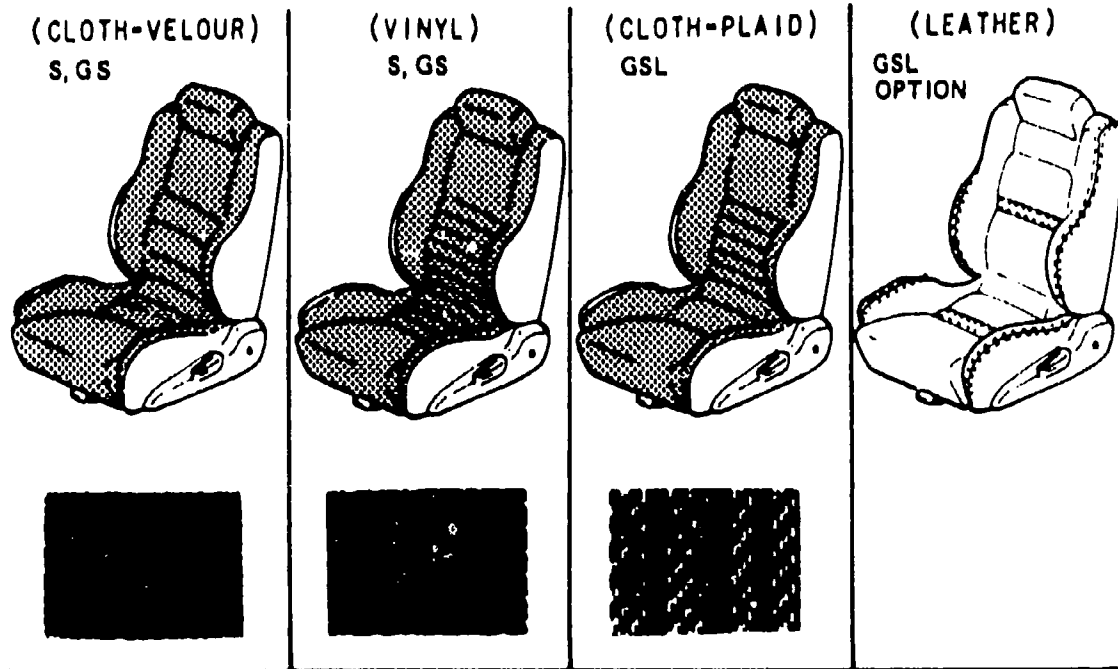

ITEM NO.	D-CODE	DESCRIPTION	PART NO.	QTY	MODEL/DESCRIPTION	REMARKS
88 104A		RESTRAINT, HEAD	FA07-88-104	2	(FOR CLOTH-VELOUR SEAT) S & GS MODELS	
		BLACK	01			
		RED	11			
		BROWN	71			
		FA08-88-014	2	(FOR VINYL SEAT) S & GS MODELS		
		BLACK	01			
		BROWN	71			
		FA09-88-104A	2	(FOR CLOTH-PLAID SEAT) GSL MODEL		
		BLACK	01			
		RED	11			
		BROWN	71			
		88 105		BUSHING	8531-88-106	2
88 106		WASHER	8531-88-105	2		
88 107A		COVER, HINGE	8531-88-107	2		
88 110		CUSHION (R), FRONT SEAT	FA07-88-110A	1	(CLOTH-VELOUR) S & GS MODELS	
		BLACK	01			
		RED	11			
		BROWN	71			
		FA08-88-110A	1	(VINYL) S & GS MODELS		
		BLACK	01			
		BROWN	71			
		FA09-88-110A	1	(CLOTH-PLAID) GSL MODEL		
		BLACK	01			
		RED	11			
		BROWN	71			
		88 111		TRIM (R), SEAT CUSHION	FA07-88-111A	1
BLACK	01					
RED	11					
BROWN	71					
FA08-88-111A	1			(VINYL) S & GS MODELS		
BLACK	01					
FA09-88-111A	1	(CLOTH-PLAID) GSL MODEL				
		BLACK	01			

5700AA-3 SEATS ('83 MODEL)

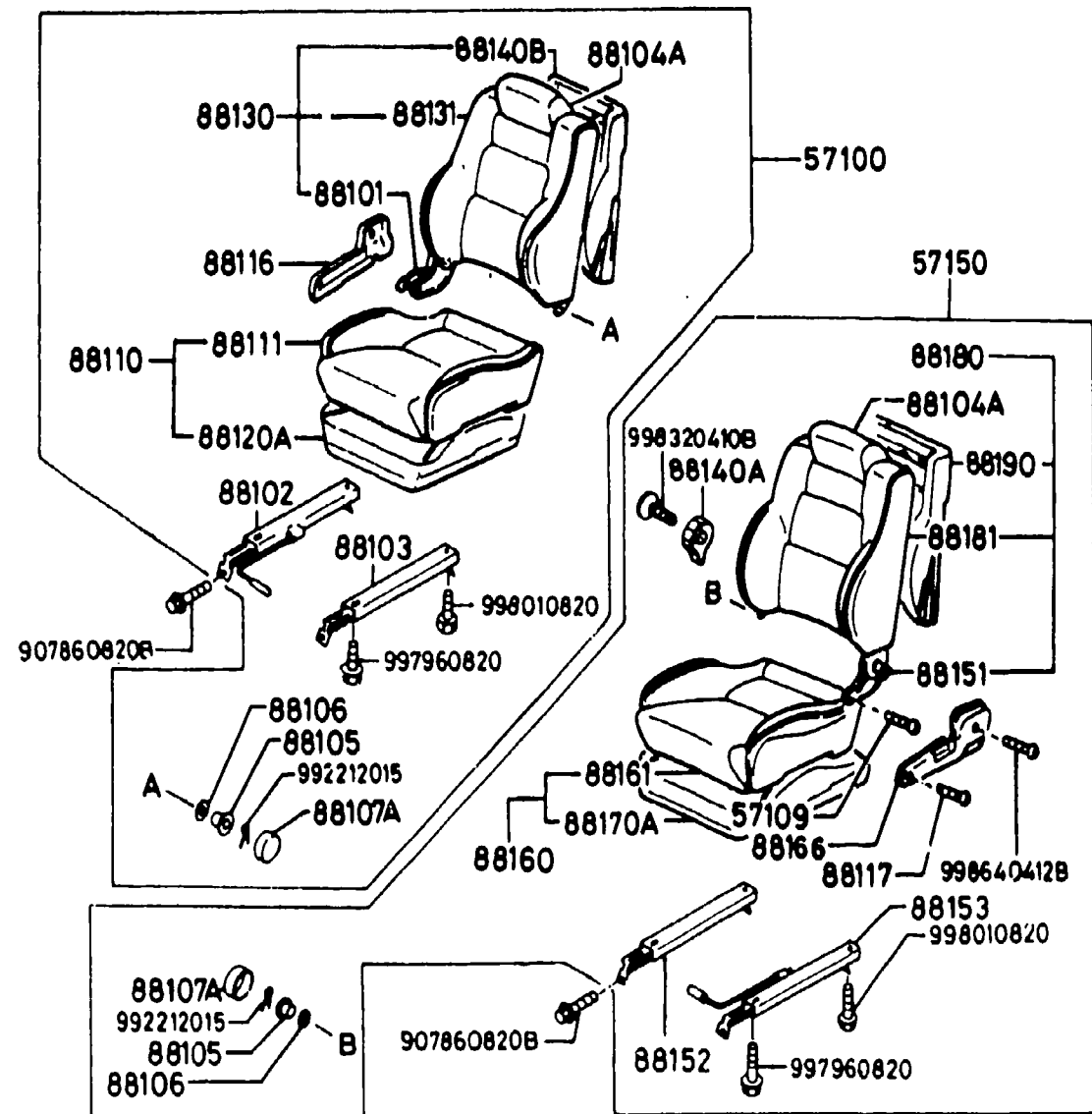
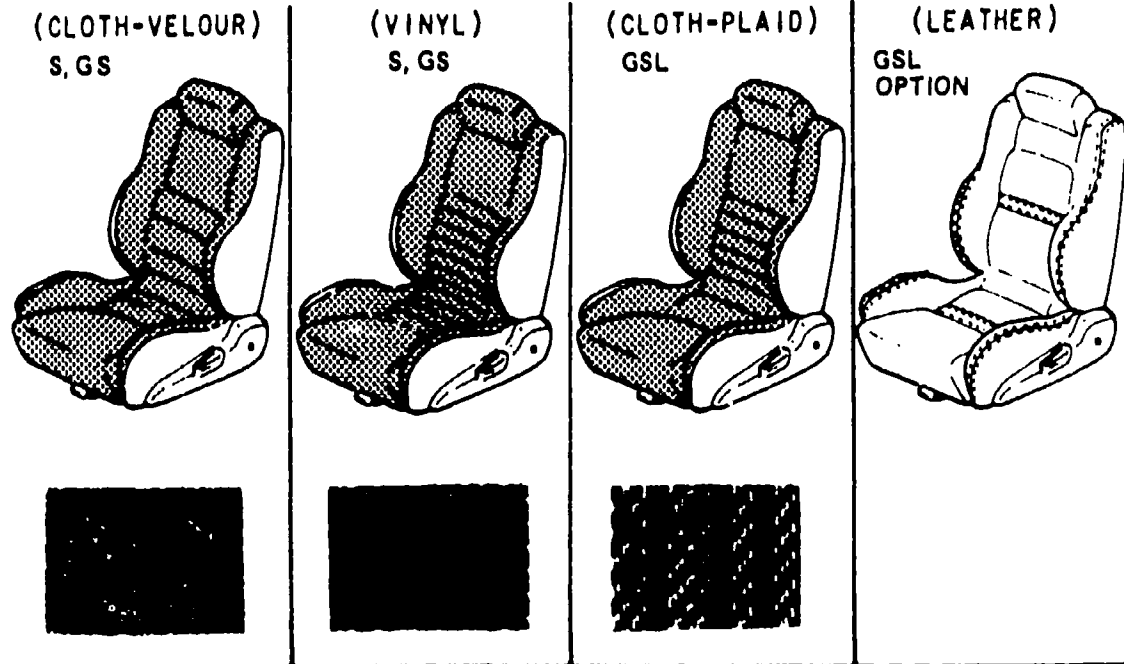

ITEM NO.	D-CODE	DESCRIPTION	PART NO.	QTY	MODEL/DESCRIPTION	REMARKS
88 111 (CONT'D)		RED	11			
		BROWN	71			
	88 116	COVER (R), KNUCKLE	8183-88-120	1		
		BLACK	00			
		RED	10			
88 117	SCREW, KNUCKLE	TAN	29			
		BROWN	70			
88 120A		FRAME & PAD (R), CUSHION	FA09-88-120	1		
88 130	BACK (R), FRONT SEAT	FA07-88-130A	1		(CLOTH-VELOUR) S & GS MODELS	
		BLACK	01			
		RED	11			
		BROWN	71			
		FA08-88-130A	1	(VINYL) S & GS MODELS		
88 131	TRIM (R), SEAT BACK	BLACK	01			
		BROWN	71			
		FA09-88-130A	1	(CLOTH-PLAID) GSL MODEL		
		BLACK	01			
		RED	11			
88 131	TRIM (R), SEAT BACK	BROWN	71			
		FA10-88-130A	1	(CLOTH-PLAID) GSL MODEL		
		BLACK	01			
88 131	TRIM (R), SEAT BACK	RED	11			
		BROWN	71			
		FA07-88-131A	1	(CLOTH-VELOUR) S & GS MODELS		
88 131	TRIM (R), SEAT BACK	BLACK	01			
		RED	11			
		BROWN	71			
88 131	TRIM (R), SEAT BACK	FA08-88-131A	1	(VINYL) S & GS MODELS		
		BLACK	01			
88 131	TRIM (R), SEAT BACK	BROWN	71			
		FA09-88-131A	1	(CLOTH-PLAID) GSL MODEL		
		BLACK	01			
88 131	TRIM (R), SEAT BACK	RED	11			
		BROWN	71			
		FA09-88-131A	1	(CLOTH-PLAID) GSL MODEL		

5700AA-4 SEATS ('83 MODEL)

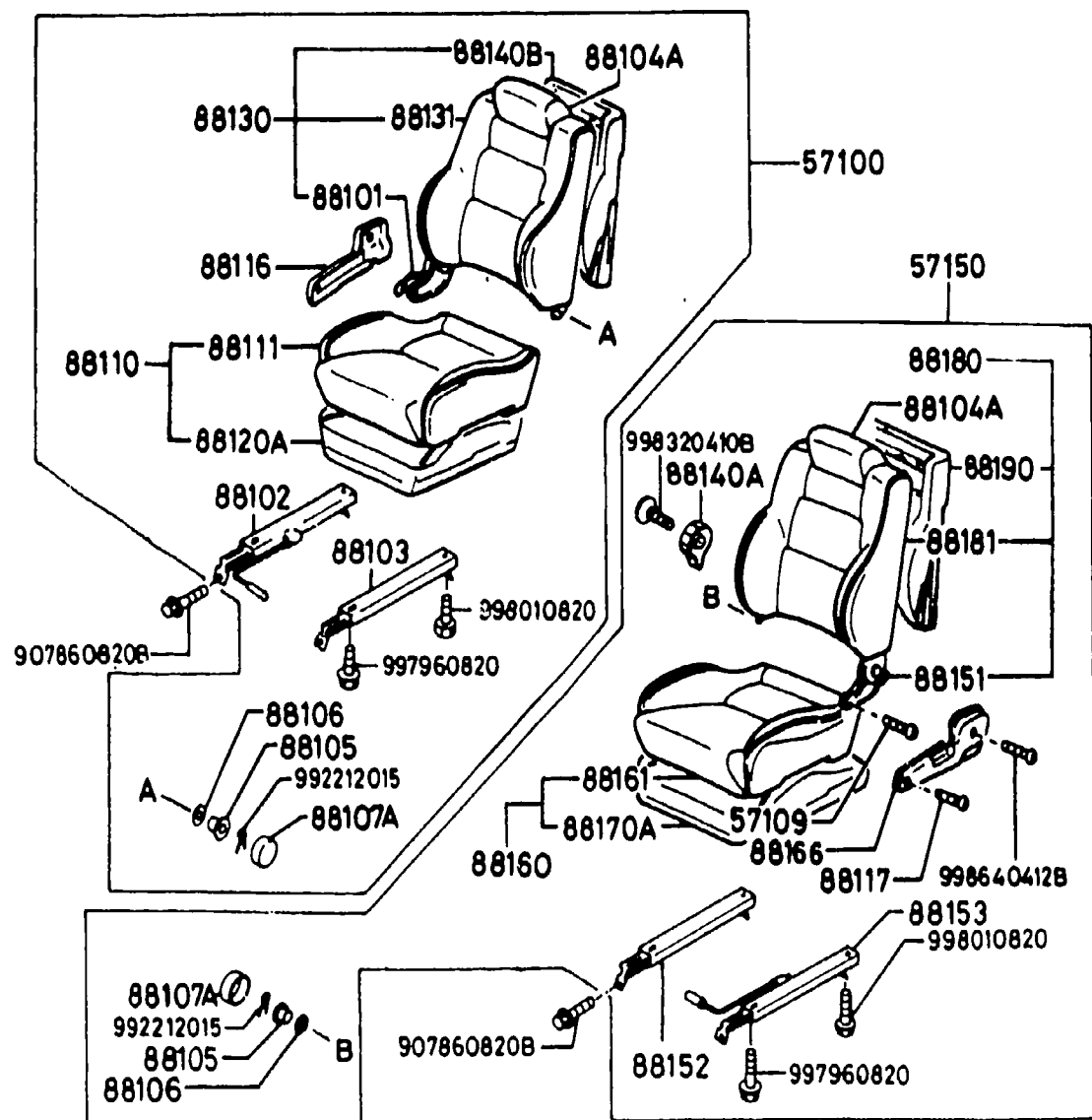
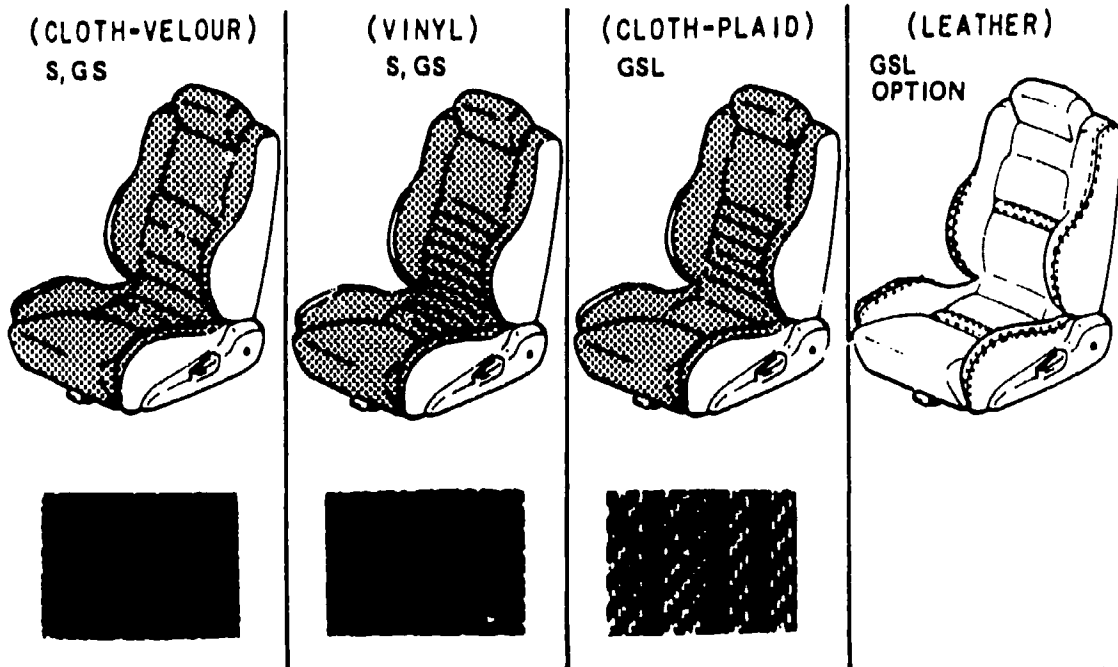

ITEM NO.	D-CODE	DESCRIPTION	PART NO.	QTY	MODEL/DESCRIPTION	REMARKS
88 140A		KNOB, LUMBAR SUPPORT	FA09-88-176	1		
		BLACK	01			
		RED	11			
		TAN	29			
		BROWN	71			
88 140B		FRAME & PAD (R), BACK	FA09-88-140	1		
88 151		KNUCKLE (L), RECLINING	FA09-88-151	1		
88 152		ADJUSTER NO. 3	FO05-88-152	1		
88 153		ADJUSTER NO. 4	FA07-88-153	1		
88 160		CUSHION (L), FRT. SEAT	FA07-88-160A	1	(CLOTH-VELOUR) S & GS MODELS	
		BLACK	01			
		RED	11			
		BROWN	71			
			FA08-88-160A	1	(VINYL) S & GS MODELS	
		BLACK	01			
		BROWN	71			
			FA09-88-160A	1	(CLOTH-PLAID) GSL MODEL	
		BLACK	01			
		RED	11			
		BROWN	71			
88 161		TRIM (L), SEAT CUSHION	FA07-88-161A	1	(CLOTH-VELOUR) S & GS MODELS	
		BLACK	01			
		RED	11			
		BROWN	71			
			FA08-88-161A	1	(VINYL) S & GS MODELS	
		BLACK	01			
		BROWN	71			
			FA09-88-161A	1	(CLOTH-PLAID) GSL MODEL	
		BLACK	01			
		RED	11			
		BROWN	71			
88 166		COVER (L), KNUCKLE	8183-88-170	1		
		BLACK	00			
		RED	10			
		TAN	29			
		BROWN	70			
88 170A		FRAME & PAD (L), CUSHION	FA09-88-170	1		

5700AA-5 SEATS ('83 MODEL)

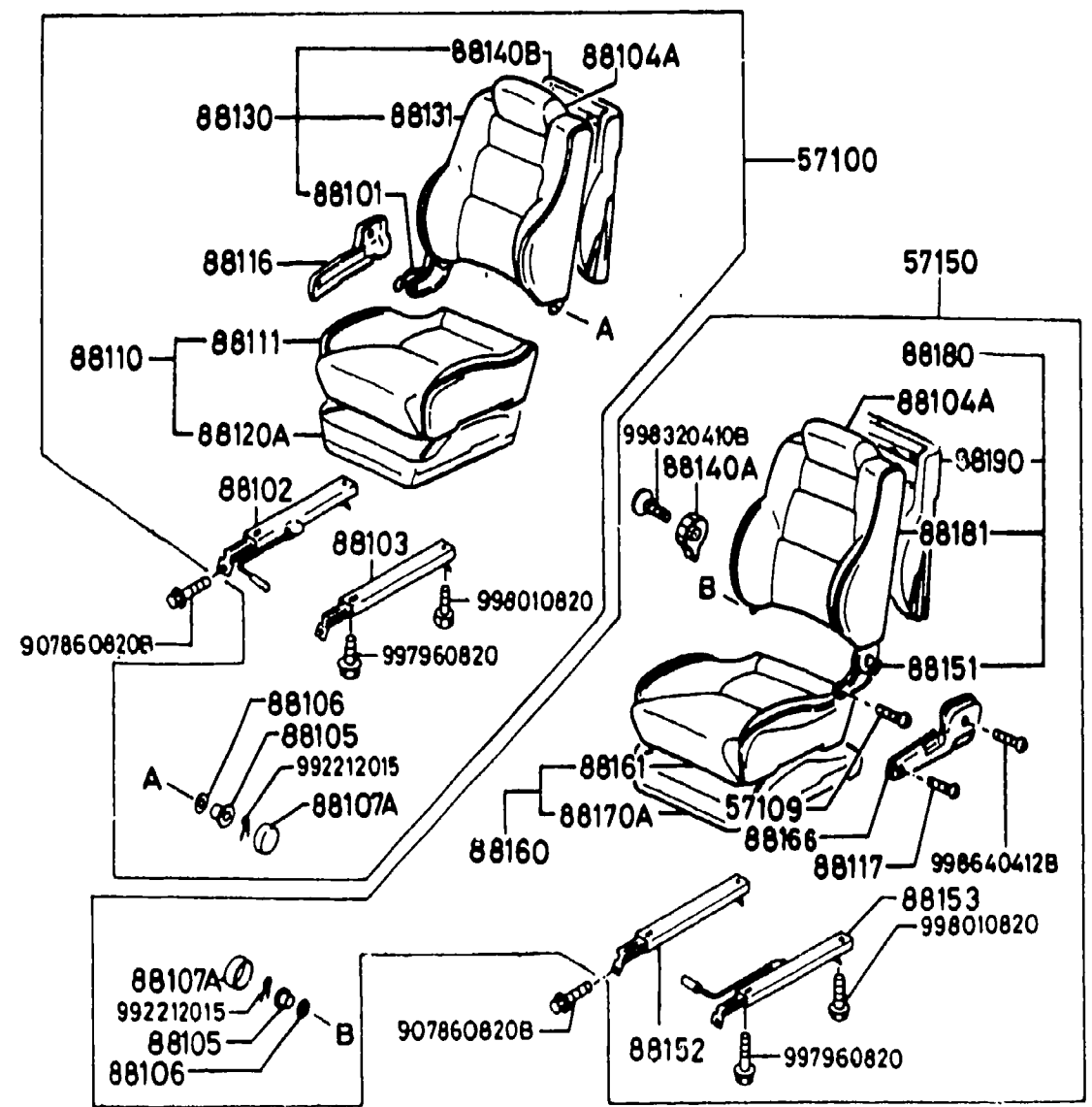
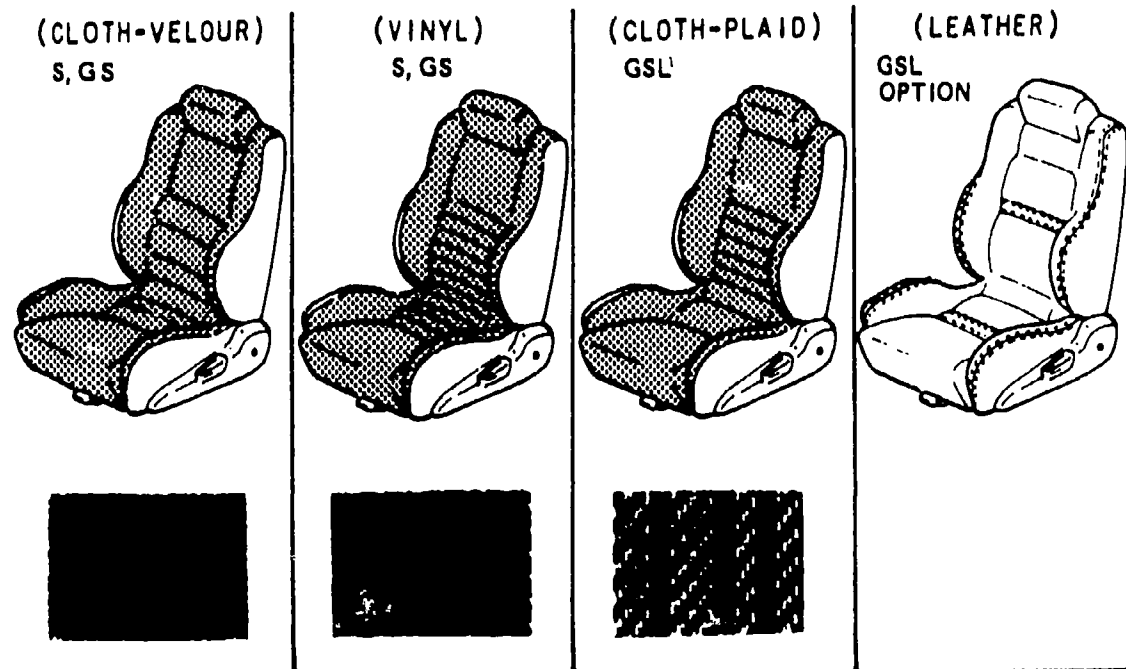

ITEM NO.	D-CODE	DESCRIPTION	PART NO.	QTY	MODEL/DESCRIPTION	REMARKS
88 180		BACK (L), FRONT SEAT	FA07-88-180A	1	(CLOTH-VELOUR) S & GS MODELS	
		BLACK	01			
		RED	11			
		BROWN	71			
		FA08-88-180A	1	(VINYL) S & GS MODELS		
		BLACK	01			
		BROWN	71			
		FA09-88-180A	1	(CLOTH-PLAID) GSL MODEL		
		BLACK	01			
		RED	11			
		BROWN	71			
		FA10-88-180A	1	(CLOTH-PLAID) GSL MODEL		
88 181		TRIM (L), SEAT BACK	FA07-88-181A	1	(CLOTH-VELOUR) S & GS MODELS	
		BLACK	01			
		RED	11			
		BROWN	71			
		FA08-88-181A	1	(VINYL) S & GS MODELS		
		BLACK	01			
		BROWN	71			
		FA09-88-181A	1	(CLOTH-PLAID) GSL MODEL		
		BLACK	01			
		RED	11			
		BROWN	71			
		88 190		FRAME & PAD (L), BACK	FA09-88-190	1

5790A-1 SEAT BELTS

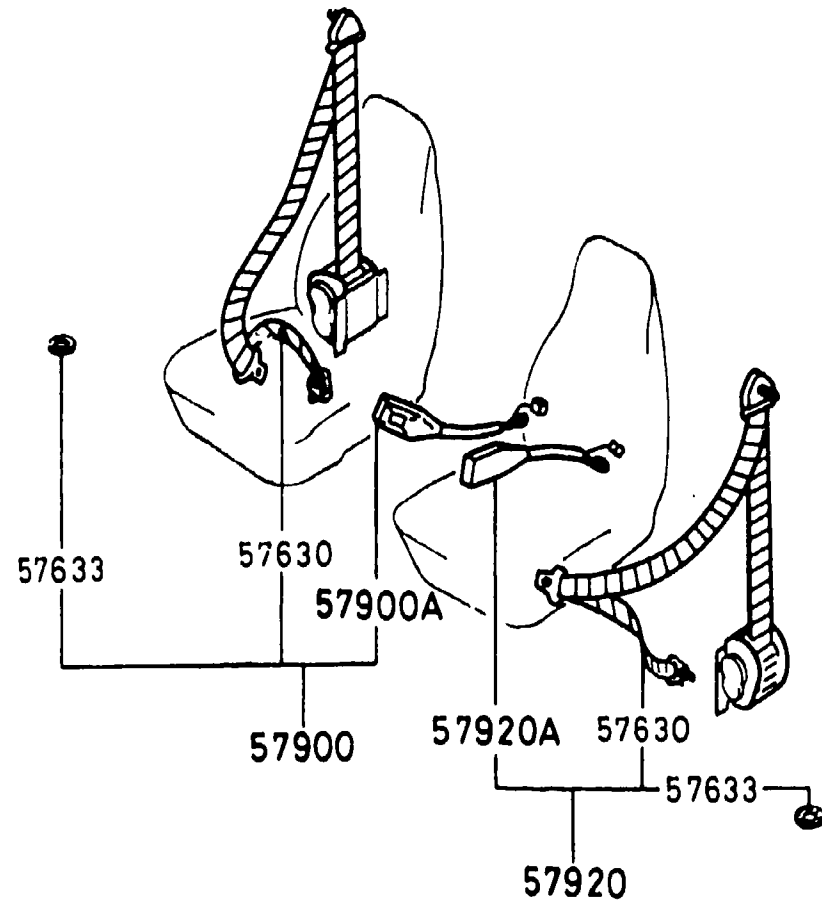

ITEM NO.	D-CODE	DESCRIPTION	PART NO.	QTY	MODEL/DESCRIPTION	REMARKS				
	57 630	BELT 'B' (R), FRONT SEAT	FA30-57-630	2	'82 & '83 MODELS					
		BLACK	00							
		RED/BLACK	12							
		BROWN	24							
	57 633	BUSHING	8872-57-633	2	'81 MODEL					
		TAN/BLACK	29							
		57 900	BELT (R), FRONT SEAT				8872-57-610A	1	'81 MODEL	FB331 ..500001-533893
		BLACK	00							
WINE/BLACK	12									
		BROWN/BLACK	24	1	'81 MODEL	FB331 ..533894-				
		8872-57-610B	00							
		WINE/BLACK	12							
		BROWN/BLACK	24							
			FA30-57-610	1	'82 MODEL	FB331 ..600001-622565				
		BLACK	00							
		WINE/RED	12							
		BROWN	24							
		TAN/BLACK	29	1	'81 MODEL					
		57 900A	BELT 'A' (R), FRONT SEAT				8872-57-620A			
		BLACK	00							
		WINE/BLACK	12							
		BROWN/BLACK	24	1	'82 & '83 MODELS					
		FA30-57-620	00							
		RED	12							
		BROWN/BLACK	24							
		TAN/BLACK	29	1	'81 MODEL	FB331 ..600001-700000				
		DARK TAN	75							
		57 920	BELT (L), FRONT SEAT				8872-57-670A	1	'81 MODEL	FB331 ..500001-533893
		BLACK	00							
WINE/BLACK	12									
		BROWN/BLACK	24	1	'81 MODEL	FB331 ..533894-				
		8872-57-670B	00							
		WINE/BLACK	12							
		BROWN/BLACK	24							
			FA30-57-670	1	'82 MODEL	FB331 ..600001-622565				
		BLACK	00							
		WINE/RED	12							

5790A-2 SEAT BELTS

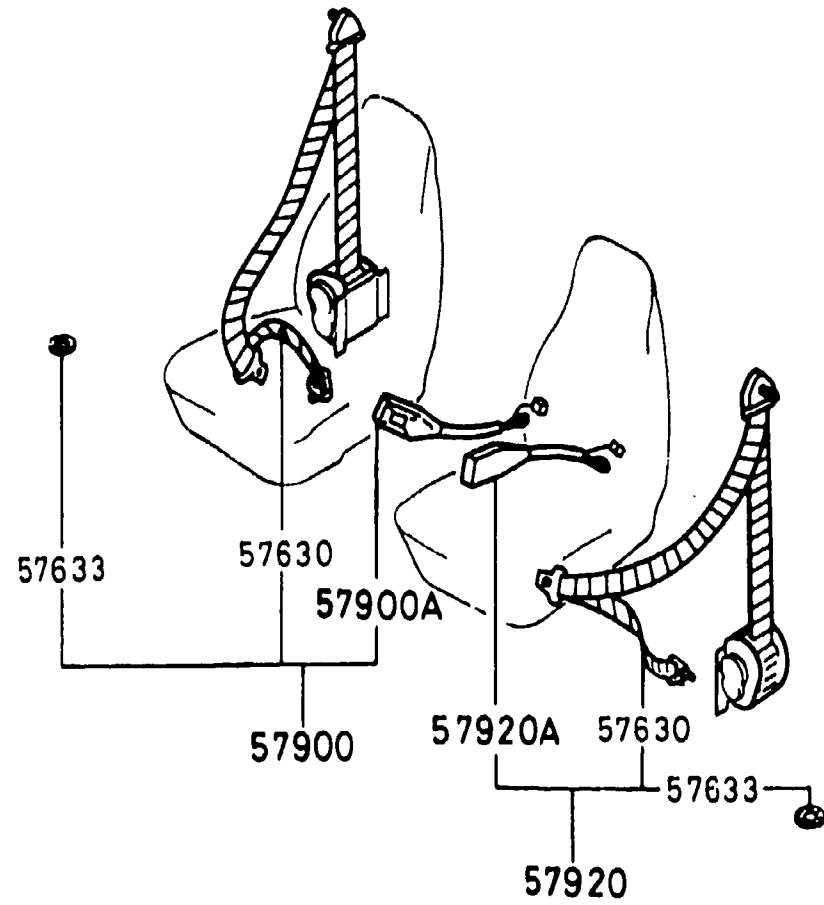

ITEM NO.	D-CODE	DESCRIPTION	PART NO.	QTY	MODEL/DESCRIPTION	REMARKS
	57 920 (CONT'D)	BROWN	24			
		TAN/BLACK	29			
	57 920A	BELT 'A' (L), FRONT SEAT	8872-57-680A	1	'81 MODEL	
		BLACK	00			
		WINE/BLACK	12			
		BROWN/BLACK	24			
			FA30-57-680	1	'82 & '83 MODELS	
		BLACK	00			
		RED	12			
		BROWN/BLACK	24			
		TAN/BLACK	29			FB331 ..600001-700000
		DARK TAN	75			FB331 ..700001-

5800A-1 FRONT DOOR

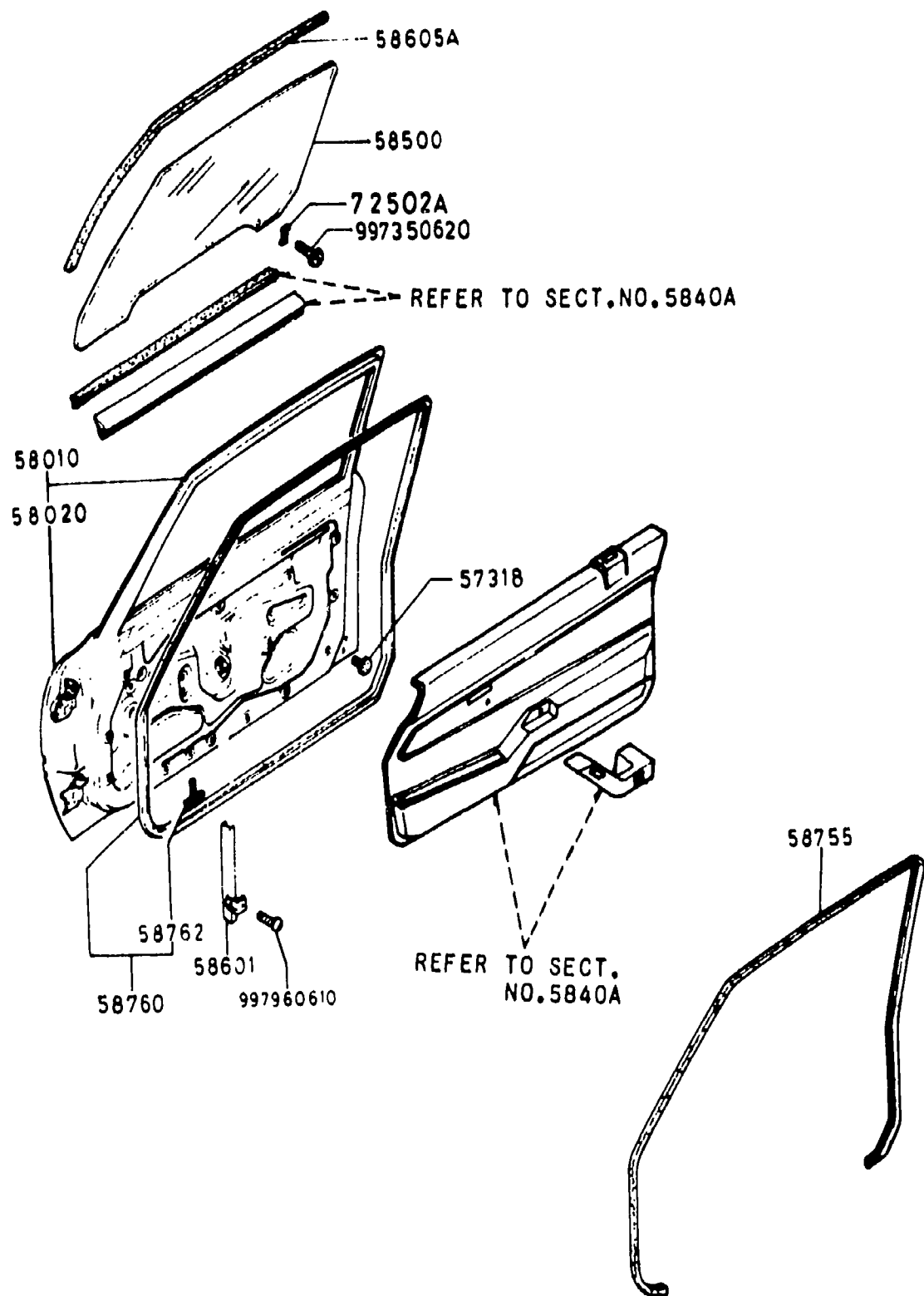

ITEM NO.	D-CODE	DESCRIPTION	PART NO.	QTY	MODEL/DESCRIPTION	REMARKS
	57 318	RUBBER, SUPPORT	0286-57-318	2		
	58 010	BODY (R), FRONT DOOR	FA54-58-010H	1		
		BODY (L), FRONT DOOR	FA54-59-010H	1		
	58 020	PANEL (R), OUTER	8981-58-020E	1		
		PANEL (L), OUTER	8871-59-020E	1		
	58 500	GLASS (R), DOOR	8871-58-501E	1		
		GLASS (L), DOOR	8871-59-501E	1		
	58 601	GUIDE 'A' (R), GLASS	8871-58-603	1		
		GUIDE 'A' (L), GLASS	8871-59-603	1		
	58 605A	CHANNEL, GLASS	8871-58-605C	2		
	58 755	WELT, SEAMING	FA02-68-911	2		
		BLACK	01			
		RED	12			
		TAN	29			
		BROWN	34			
	58 760	WFATHERSTRIP (R), DOOR	8871-58-760	1		
		WEATHERSTRIP (L), DOOR	8871-59-760	1		
	58 762	FASTENER	0305-58-762	42		
	72 502A	GROMMET, SCREW	8544-72-502	4		

5830A-1 FRONT DOOR MECHANISM

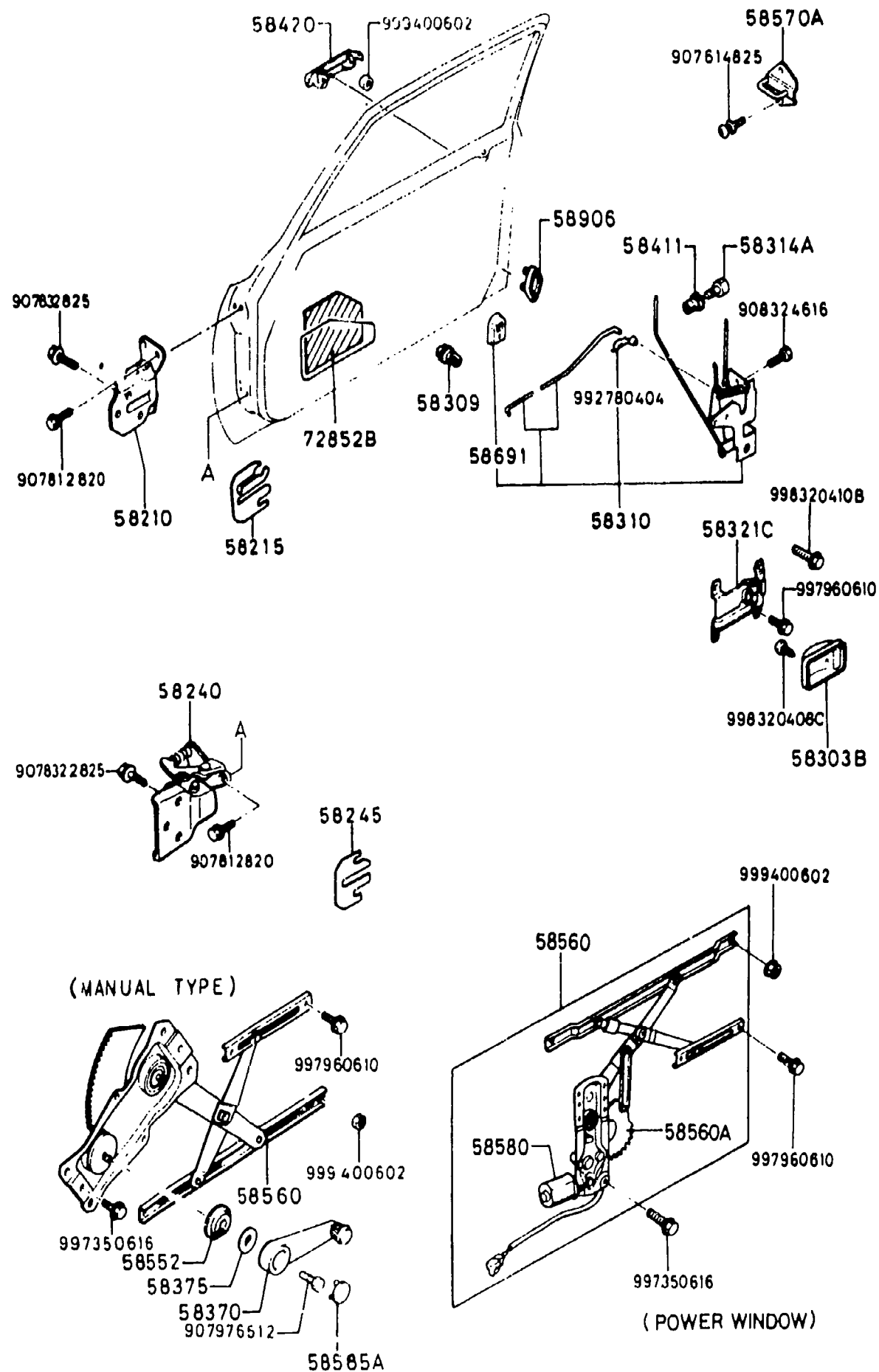

ITEM NO.	D-CODE	DESCRIPTION	PART NO.	QTY	MODEL/DESCRIPTION	REMARKS
58 210		HINGE (R), DOOR-UPPER	8871-58-210	1		
		HINGE (L), DOOR-UPPER	8871-59-210	1		
58 215		SPACER, HINGE-UPPER	1011-58-231	2		
58 240		HINGE (R), DOOR-LOWER	8032-58-240	1		
		HINGE (L), DOOR-LOWER	8531-59-240A	1		
58 245		SPACER, HINGE-LOWER	8531-58-231A	2		
58 303B		COVER, INNER HANDLE	8116-58-303	2		
		BLACK	00			
		RED	12			
		BROWN	27			
		TAN	29			
58 309		HOLDER, ROD	0305-58-309	4		
58 310		LOCK (R), DOOR	8871-58-310E	1	'81 & '82 MODELS	
			F023-58-310	1	'83 MODEL	
		LOCK (L), DOOR	8871-59-310E	1	'81 & '82 MODELS	
			F023-59-310	1	'83 MODEL	
58 314A		JOINT	1243-58-314	2		
58 321C		HANDLE, INNER	8545-58-330	2		
58 370		HANDLE, REGULATOR	8038-58-580A	2	S & GS MODELS	
		BLACK	02			
		RED	12			
		BROWN	27			
		TAN	29			
58 375		ESCUTCHEON	0223-58-375A	2	S & GS MODELS	
		BLACK	00			
		RED	12			
		BROWN	27			
		TAN	29			
58 411		BUSHING	1243-58-411	2		
58 420		HANDLE (R), OUTER	8871-58-410C	1		
		HANDLE (L), OUTER	8871-59-410C	1		
58 552		GASKET, REGULATOR HANDLE	0259-58-305B	2		
58 560		REGULATOR (R), WINDOW	8871-58-560A	1	S & GS MODELS	
			FA02-58-560	1	GSL MODEL	
		REGULATOR (L), WINDOW	8871-59-560A	1	S & GS MODELS	
			FA02-59-560	1	GSL MODEL	
58 560A		ARM (R), REGULATOR	FA02-58-590	1	GSL MODEL	
		ARM (L), REGULATOR	FA02-59-590	1	GSL MODEL	
58 570A		STRIKER	8531-58-361	2		
58 580		MOTOR (R), WINDOW	G018-59-580	1	GSL MODEL	

FB331 ..600001-

FB331 ..600001-

FB331 ..600001-

5830A-2 FRONT DOOR MECHANISM

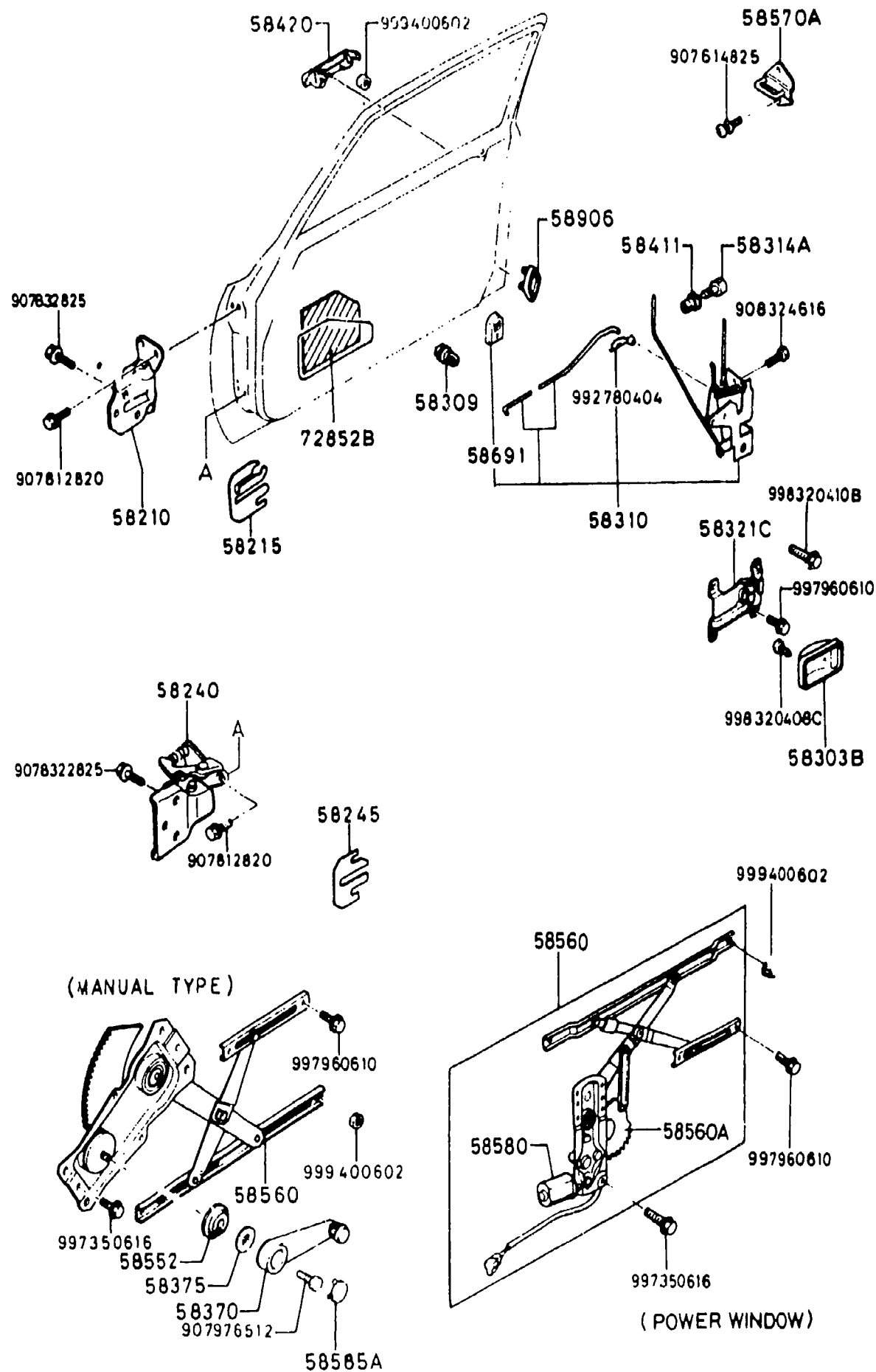

ITEM NO.	D-CODE	DESCRIPTION	PART NO.	QTY	MODEL/DESCRIPTION	REMARKS
58 580	(CONT'D)	< A >	G019-59-580	1		
		MOTOR (L), WINDOW	G018-58-580	1	GSL MODEL	
		< A >	G019-58-580	1		
58 585A		CAP, REGULATOR HANDLE	8037-58-585	2	S & GS MODELS	
		BLACK	02			
		RED	12			
		BROWN	27			
		TAN	29			
58 691		KNOB, DOOR LOCK	G030-58-316A	2		FB331 ..600001-
		BLACK	00			
58 906		CUSHION, DOOR	0259-58-906	2		
72 852B		INSULATION	0305-72-852A	2	'82 & '83 MODELS	

SECTION INDEX -- BODY

STARTING LOCATION	SECT. NO.	SECTION NAME	STARTING LOCATION	SECT. NO.	SECTION NAME	STARTING LOCATION	SECT. NO.	SECTION NAME
2 - C 3	0900A	KEY SETS	2 - C 8	6132AC	CONDENSER PACKAGE ('83 MODEL)	2 - H 11	6870A	SERVICE TOOLS
2 - D 3	5000A	FRONT BUMPER	2 - E 8	6142A	COMPRESSOR MOUNTING KIT, COMPRESSOR CLUTCH ASSEMBLY & REPAIR PARTS ('81 MODEL)	2 - I 11	6900A	VISOR, ASSIST HANDLE & MIRRORS
2 - E 3	5005A	RADIATOR GRILLE	2 - F 8	6142AB	COMPRESSOR MOUNTING KIT, COMPRESSOR CLUTCH ASSEMBLY & REPAIR PARTS ('82 MODEL)	2 - L 11	6930A	CAUTION PLATES
2 - F 3	5010A	REAR BUMPER	2 - G 8	6142AC	COMPRESSOR MOUNTING KIT, COMPRESSOR CLUTCH ASSEMBLY & REPAIR PARTS ('83 MODEL)			
2 - G 3	5030A	WINDOW MOULDINGS	2 - H 8	6152A	EVAPORATOR PACKAGE ('81 MODEL)			
2 - H 3	5040A	BODY MOULDINGS	2 - I 8	6152AB	EVAPORATOR PACKAGE ('82 MODEL)			
2 - I 3	5060A	SIDE PROTECTORS	2 - J 8	6152AC	EVAPORATOR PACKAGE ('83 MODEL)			
2 - J 3	5100A	HEAD LAMPS	2 - K 8	6230A	BACK DOOR MECHANISM			
2 - K 3	5103A	HEAD LAMP RETRACTORS	2 - L 8	6300A	WINDOW GLASSES			
2 - L 3	5105A	FRONT COMBINATION & SIDE TURN LAMPS	2 - M 8	6330A	SUNROOF (GSI)			
2 - M 3	5110A	REAR COMBINATION LAMPS	2 - N 8	6600A	SWITCH & RELAY (ENGINE & TRANSMISSION)			
2 - N 3	5120A	LICENSE & REAR SIDE TURN LAMPS	2 - C 9	6610A	DASHBOARD SWITCHES (MANUAL OPERATING)			
2 - C 4	5125A	INTERIOR LAMPS (GS & GSI)	2 - D 9	6611A	COMBINATION SWITCH			
2 - D 4	5170A	ORNAMENTS	2 - E 9	6615A	POWER WINDOW SWITCH			
2 - E 4	5180A	COWL & EXTRACTOR GRILLES	2 - F 9	6620A	DOOR, PARKING LAMP & KICK DOWN SWITCH			
2 - F 4	5230A	HOOD	2 - G 9	6630A	RELAY (BODY)			
2 - G 4	5310A	BODY PANELS (FRONT)	2 - H 9	6635A	HORN			
2 - I 4	5340A	BODY PANELS (SIDE & ROOF)	2 - I 9	6640A	AUTO CRUISE CONTROL			
2 - J 4	5360A	BODY PANELS (FLOOR)	2 - J 9	6680A	AUDIO SYSTEM			
2 - K 4	5370A	FLOOR ATTACHMENTS	2 - M 9	6700A	WIRE HARNESS (FRONT & REAR)			
2 - L 4	5500A	DASHBOARD EQUIPMENT	2 - N 9	6701A	WIRE HARNESS (ENGINE & TRANSMISSION)			
2 - N 4	5540A	METERS	2 - C 10	6702A	WIRE HARNESS (DASHBOARD)			
2 - C 5	5560A	DASHBOARD & RELATED	2 - D 10	6703A	WIRE HARNESS (DOOR, FLOOR & CEILING)			
2 - E 5	5570A	CONSOLE	2 - E 10	6704A	WIRE HARNESS CLAMPS			
2 - G 5	5580A	VENTILATOR	2 - F 10	6720A	WINDSHIELD WASHER			
2 - H 5	5700A	SEATS ('81 & '82) MODELS	2 - G 10	6730A	WINDSHIELD WIPER			
2 - C 6	5700AA	SEATS ('83 MODEL)	2 - H 10	6740A	WIPER MOTOR (COMPONENTS ONLY)			
2 - H 6	5790A	SEAT BELTS	2 - I 10	6750A	REAR WINDOW WIPER & WASHER			
2 - J 6	5800A	FRONT DOOR	2 - J 10	6760A	RE/R WINDOW WIPER MOTOR (COMPONENTS ONLY)			
2 - K 6	5830A	FRONT DOOR MECHANISM	2 - K 10	6800A	CEILING TRIM			
2 - C 7	5840A	FRONT DOOR TRIM & RELATED PARTS	2 - C 11	6840A	TRIM & SCUFF PLATE			
2 - F 7	6100A	HEATER	2 - F 11	6860A	FLOOR MATS & PADS			
2 - G 7	6110A	HEATER UNIT						
2 - H 7	6115A	HEATER CONTROLS						
2 - I 7	6120A	HEATER BLOWER						
2 - J 7	6132A	CONDENSER PACKAGE ('81 MODEL)						
2 - L 7	6132AB	CONDENSER PACKAGE ('82 MODEL)						

5840A-1 FRONT DOOR TRIM & RELATED PARTS

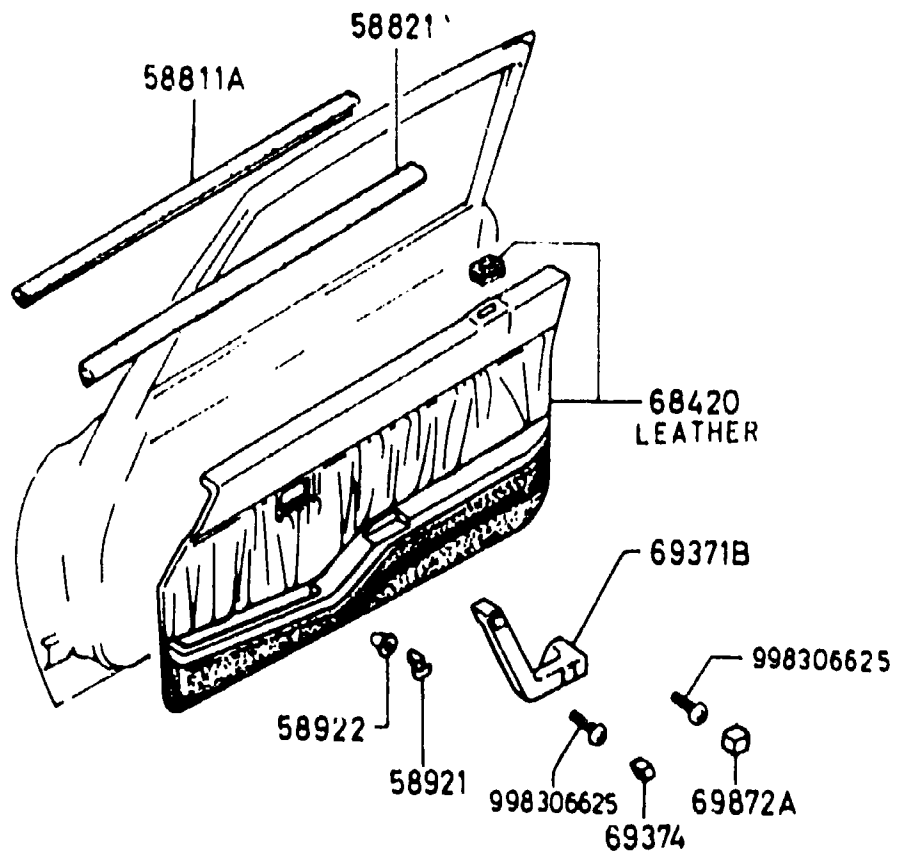

CLOTH

VINYL

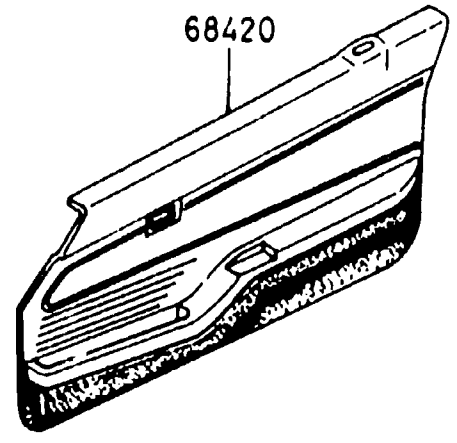
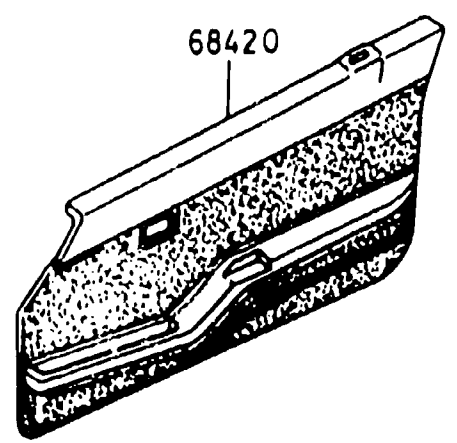

ITEM NO.	D-CODE	DESCRIPTION	PART NO.	QTY	MODEL/DESCRIPTION	REMARKS
58 811A		WEATHERSTRIP, OUTER	8871-53-781	2		
58 821A		WEATHERSTRIP, INNER	8871-58-791	2		
58 921		FASTENER	0208-58-921	22		
58 922		CAP. FASTENER	0187-58-922	22		
68 420		TRIM (R), DOOR	FA01-68-420A	1	S & GS MODELS	
		RED	10			
			< A >			
		BLACK	00		(VINYL)	
		RED	10		S & GS MODELS	
		BROWN	70			
			FA02-68-420D	1	(CLOTH)	
					S & GS MODELS	
		BLACK	00			
		RED	10			
		BROWN	70			
			FA03-68-420A	1	(CLOTH)	
					GSL MODEL	
		RED	10			
			< A >			
			FA03-68-420D	1	(CLOTH)	
					GSL MODEL	
		BLACK	00			
		RED	10			
		BROWN	70			
			FA04-68-420A	1	(LEATHER)	
					'81 GSL MODEL	FB331 ..500001-600000
		RED	10			
		BROWN	70			
			FA05-68-420C	1	(LEATHER)	
					GSL MODEL	
		RED	10			
		TAN	29			
		BROWN	70			
			FA42-68-420A	1	(VINYL)	
					'83 S & GS MODELS	
		BLACK	01			
		RED	11			
		BROWN	71			
		TRIM (L), DOOR	FA01-68-450D	1	(VINYL)	
					S & GS MODELS	
		BLACK	00			
		RED	10			
		BROWN	70			

5840A-2 FRONT DOOR TRIM & RELATED PARTS

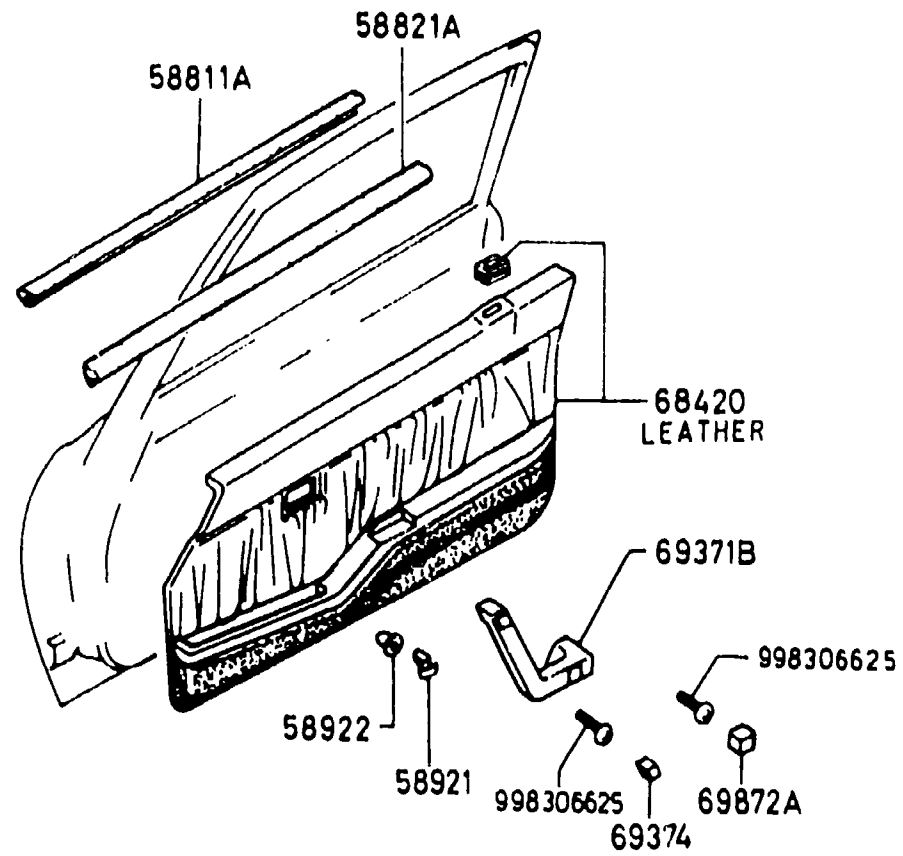

CLOTH

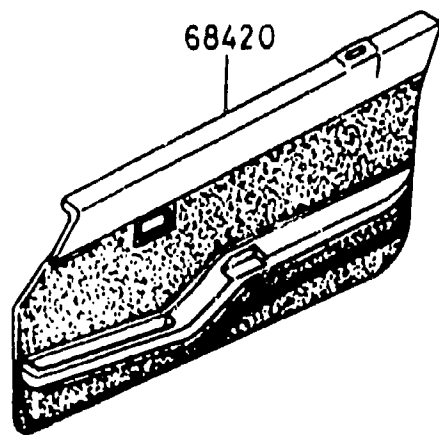

VINYL

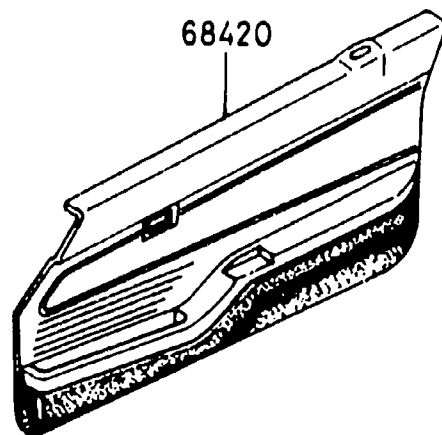

ITEM NO.	D-CODE	DESCRIPTION	PART NO.	QTY	MODEL/DESCRIPTION	REMARKS
	68 420 (CONT'D)		FA02-68-450D	1	(CLOTH) S & GSL MODELS	
		BLACK	00			
		RED	10			
		BROWN	70			
			FA03-68-450D	1	(CLOTH) GSL MODEL	
		BLACK	00			
		RED	10			
		BROWN	70			
			FA05-68-450C	1	(LEATHER) GSL MODEL	
		RED	10			
		BROWN	70			
			FA42-68-450A	1	(VINYL) '83 S & GS MODELS	
		BLACK	01			
		RED	11			
		BROWN	71			
	69 371B	HANDLE (R), PULL	FA01-69-371A	1		
		BLACK	00			
		RED	10			
		TAN	29			FB331 ..600001-
		BROWN	80			
		HANDLE (L), PULL	FA01-69-391A	1		
		BLACK	00			
		RED	10			
		TAN	29			FB331 ..600001-
		BROWN	80			
	69 374	CAP (R), PULL HANDLE	FA01-69-372	1		
		BLACK	00			
		RED	10			
		TAN	29			FB331 ..600001-
		BROWN	80			
		CAP (L), PULL HANDLE	FA01-69-392	1		
		BLACK	00			
		RED	10			
		TAN	29			FB331 ..600001-
		BROWN	80			
	69 872A	CAP, PULL HANDLE	FA01-69-374	6		
		BLACK	00			

5840A-3 FRONT DOOR TRIM & RELATED PARTS

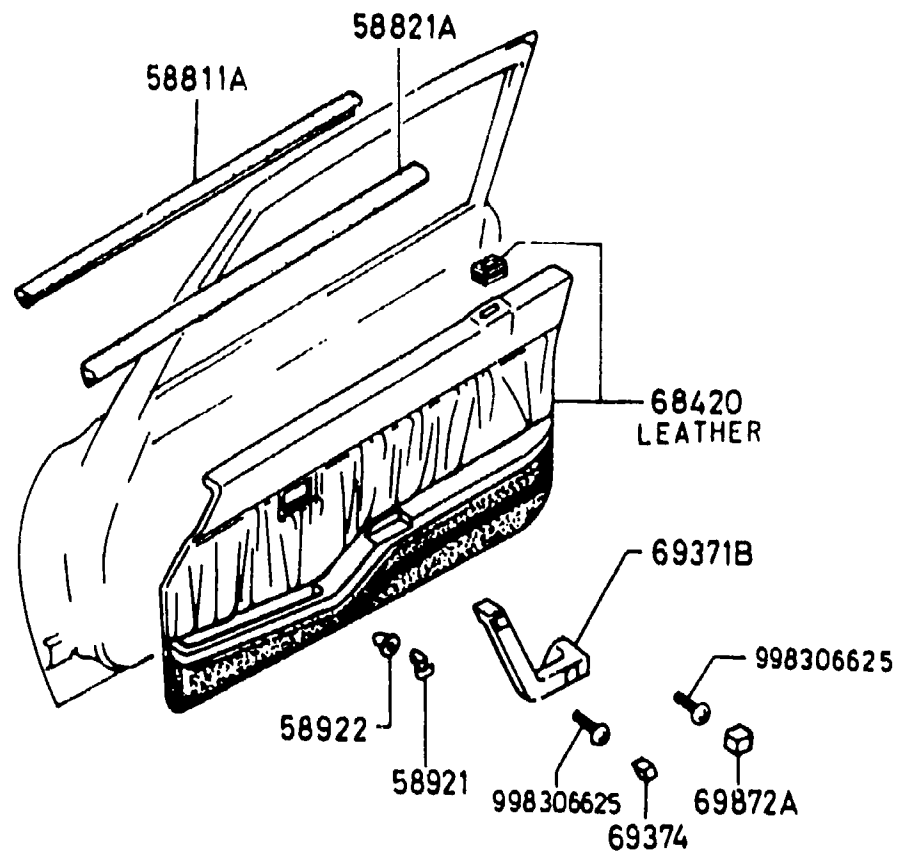

CLOTH

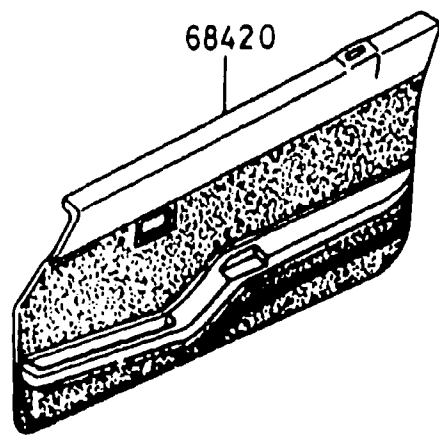

VINYL

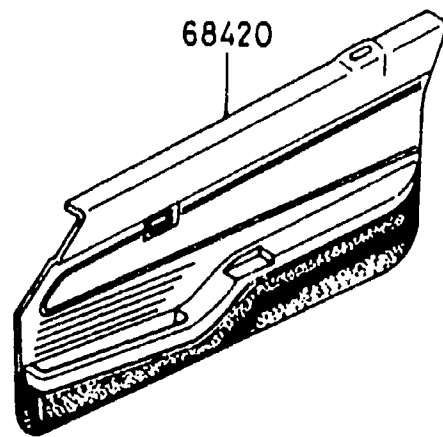

ITEM NO.	D-CODE	DESCRIPTION	PART NO.	QTY	MODEL/DESCRIPTION	REMARKS
	69 872A (CONT'D)	RED	10			
		TAN	29			FB331 ..600001-
		BROWN	80			

6100A-1 HEATER

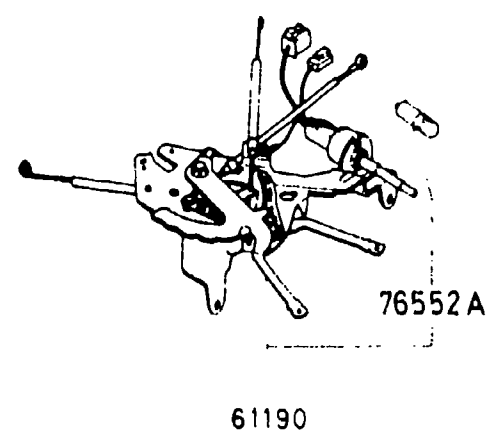
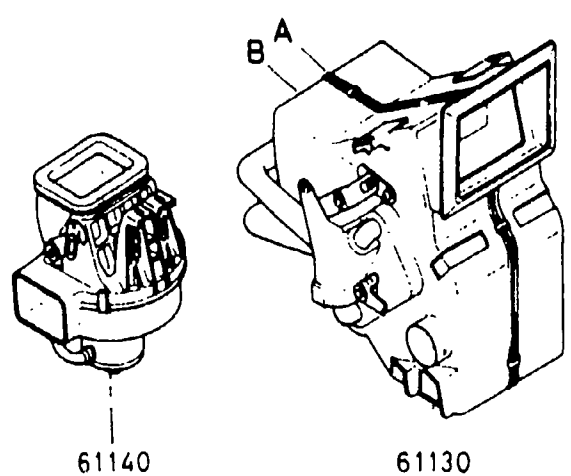
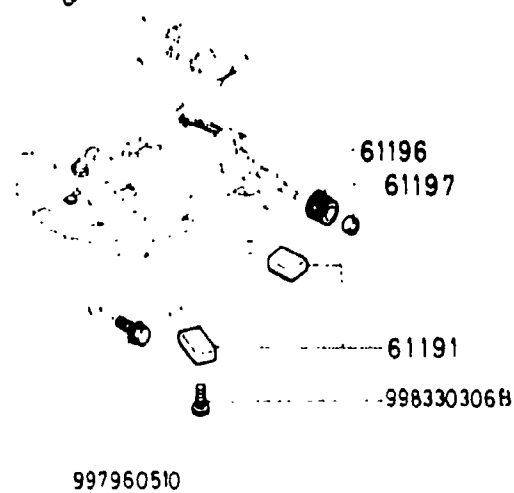
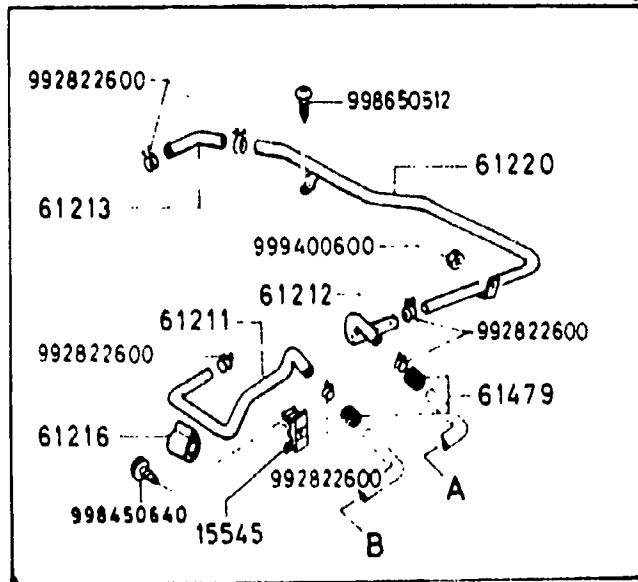
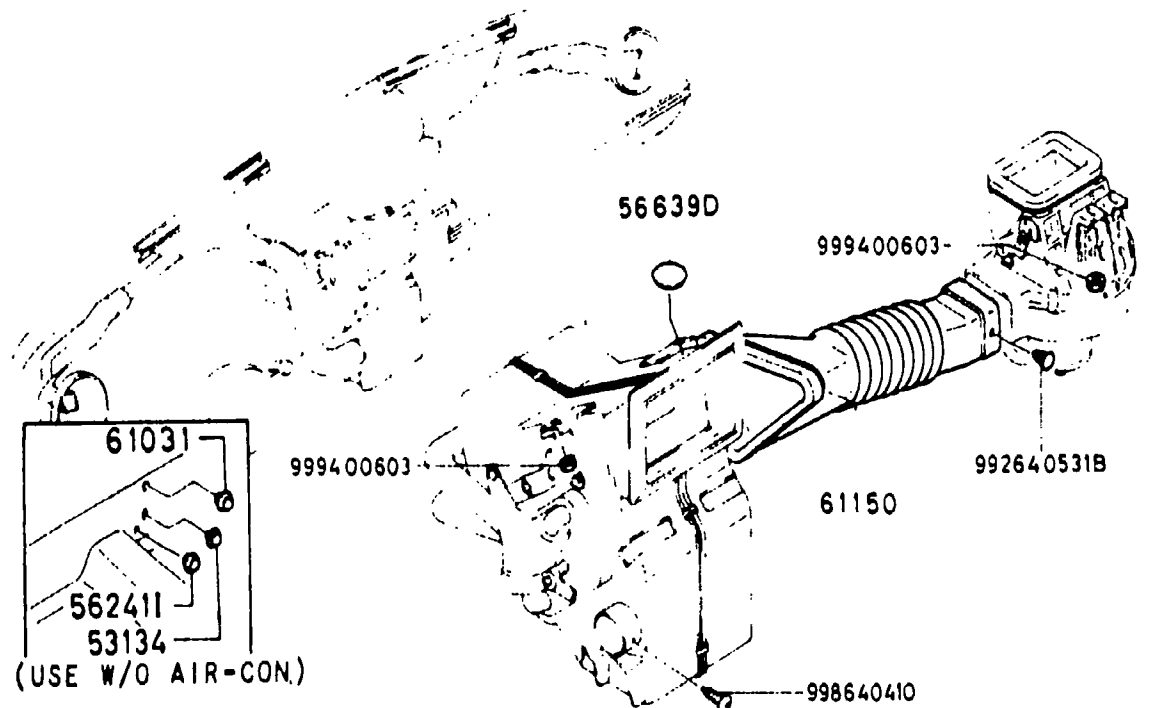

ITEM NO.	D-CODE	DESCRIPTION	PART NO.	QTY	MODEL/DESCRIPTION	REMARKS
15 545		CLIP, HEATER HOSE	N231-15-545	1	'83 MODEL	
53 134		PLUG, DRAIN	0187-53-134	1	(USE W/O A/C)	
56 241		PLUG, DRAIN	0118-56-241	1	(USE W/O A/C)	
		< A >	B499-62-868	1		
56 639D		COVER, SERVICE HOLE	0810-56-639	1		
61 031		PLUG, HOLE	1708-61-031	1	(USE W/O A/C)	
61 130		HEATER UNIT	FA42-61-130	1		
61 140		BLOWER	8871-61-140A	1		
61 150		DUCT	8871-61-150	1	(USE W/O A/C)	
61 190		CONTROL, HEATER	FA01-61-190	1	'81 & '82 MODELS THRU JAN. '82 PROD.	FB331 ..500001-633360
			FA01-61-190A	1	'82 & '83 MODELS FROM FEB. '82 PROD.	FB331 ..633361-
61 191		KNOB NO. 1	8171-61-191A	2		
61 196		KNOB	8563-61-196A	1		
61 197		KNOB, A/C	8563-61-197B	1		
61 211		HOSE NO. 1, WATER	8871-61-230	1	'81 & '82 MODELS	
			N231-15-550	1	'83 MODELS	
61 212		HOSE NO. 2, WATER	8871-61-212	1		
61 213		HOSE NO. 3, WATER	8871-61-213	1	'81 & '82 MODELS	
			FA42-61-213A	1	'83 MODEL	
61 216		PROTECTOR	1011-61-216	1	'81 & '82 MODELS	
61 220		PIPE, HEATER	F001-61-220B	1	'81 & '82 MODELS	
			FA42-61-220C	1	'83 MODELS	
61 479		GROMMET	8871-61-219A	2		
76 552A		BULB	8595-76-552	1		

6110A-1 HEATER UNIT

COMPONENTS OF FA42-61-130

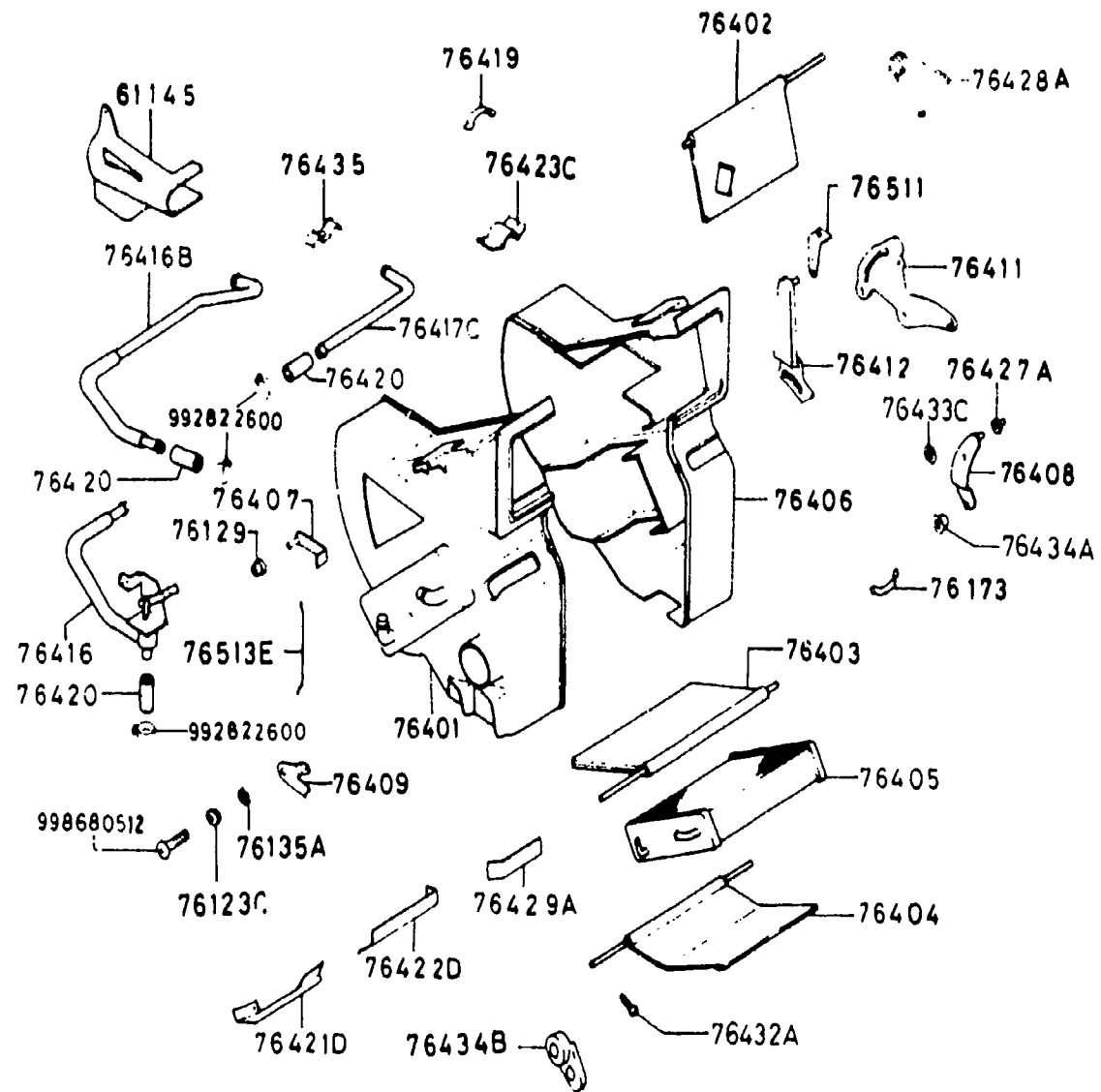

ITEM NO.	D-CODE	DESCRIPTION	PART NO.	QTY	MODEL/DESCRIPTION	REMARKS
	61 145	COVER, HEATER	8871-76-418	1		
	76 123C	BUSHING	8871-76-414	3		
	76 129	BUSHING	8871-76-470	1		
	76 135A	SPRING	8871-76-415	3		
	76 173	CLAMP	8871-76-466	6		
	76 401	CASE, HEATER	FA42-76-401	1		
	76 402	SHUTTER NO. 1	FA42-76-403	1		
	76 403	SHUTTER NO. 2	8871-76-405	1		
	76 404	SHUTTER NO. 3	8871-76-410A	1		
	76 405	CORE, HEATER	8871-76-402	1		
	76 406	CASE, HEATER	FA42-76-400A	1		
	76 407	LEVER NO. 1, CONTROL	8871-76-406	1		
	76 408	LEVER, CONTROL	8871-76-413	1		
	76 409	LEVER NO. 2, CONTROL	8871-76-407	1		
	76 411	LEVER, CONTROL	8871-76-411A	1		
	76 412	LEVER, CONTROL	8871-76-412A	1		
	76 416	VALVE, WATER	8871-76-409	1		
	76 416B	PIPE	8871-76-416	1		
	76 417C	PIPE	8871-76-417	1		
	76 419	CLIP	8871-76-471	1		
	76 420	HOSE	8871-76-420	3		
	76 421D	GUIDE	8871-76-421	1		
	76 422D	GUIDE	8871-76-422	1		
	76 423C	BAND, HOSE	8871-76-425	2		
	76 427A	BUSHING	8871-76-427	1		
	76 428A	SPRING	8871-76-428	1		
	76 429A	GUIDE	FA42-76-429	1		
	76 432A	WASHER & SCREW	8871-76-432	1		
	76 433C	WASHER	8871-76-433	1		
	76 434A	BUSHING, STEPPED	8871-76-434	1		
	76 434B	PLATE	8871-76-430A	1		
	76 435	CLIP	8871-76-419	2		
	76 511	PLATE, HEATER UNIT	8871-76-404	1		
	76 513E	SHAFT	8871-76-408	1		

6115A-1 HEATER CONTROLS

COMPONENTS OF FA01-61-190

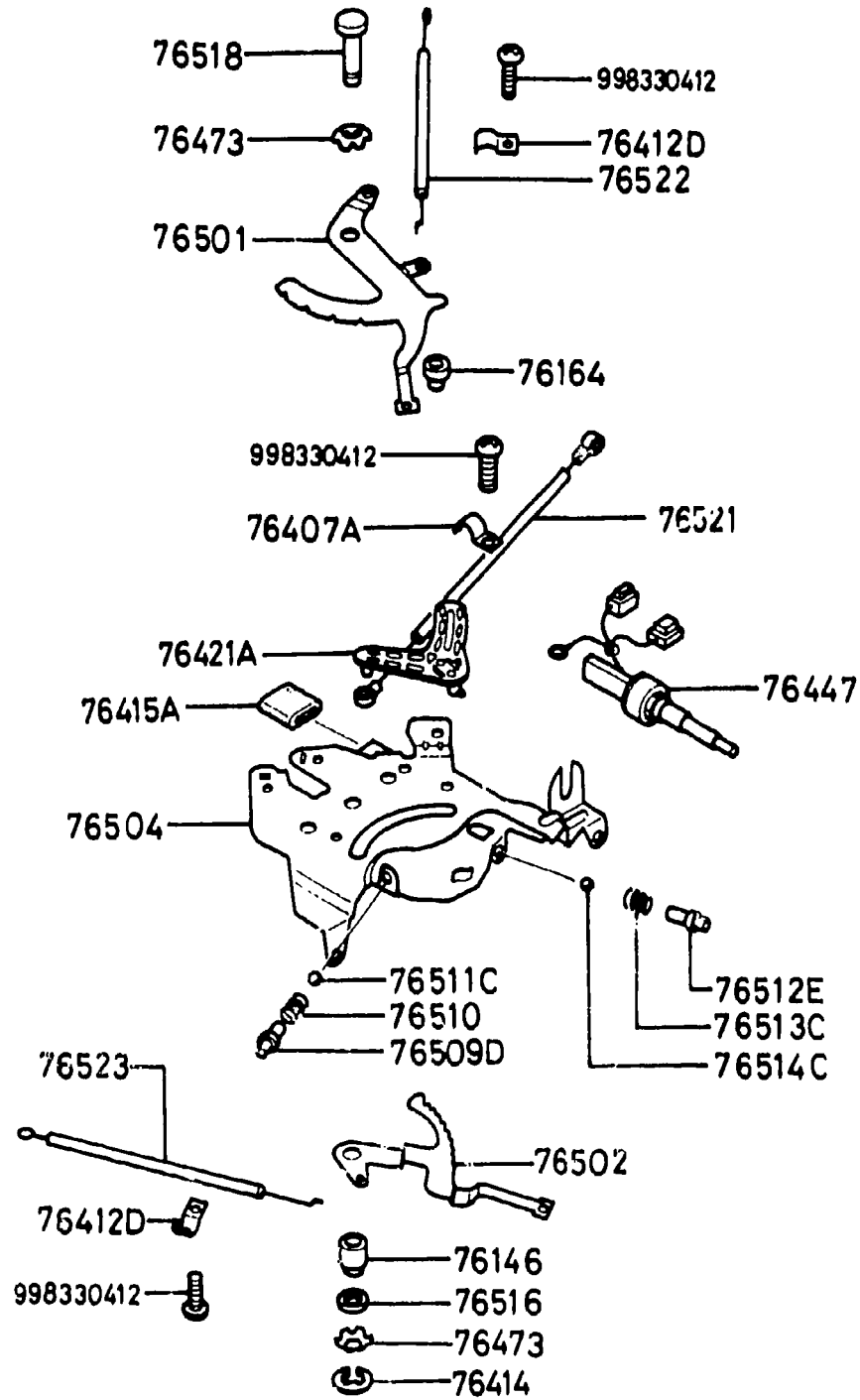

ITEM NO.	D-CODE	DESCRIPTION	PART NO.	QTY	MODEL/DESCRIPTION	REMARKS
	76 146	BUSHING	8871-76-516	1		
	76 164	BUSHING	8871-76-518	1		
	76 407A	CLAMP, CABLE	8562-76-508	1		
	76 412D	CLAMP, CABLE	8871-76-508	2		
	76 414	RING, SNAP	0259-71-158	1		
	76 415A	BUSHING	8531-76-415	1		
	76 421A	PLATE	8871-76-503A	1		
	76 447	SWITCH	8563-76-504	1		
	76 473	WASHER	0315-76-028	2		
	76 501	LEVER, CONTROL	FA01-76-502	1	(SELECTOR)	
	76 502	LEVER, CONTROL	8249-76-501	1	(TEMPERATURE)	
	76 504	BRACKET	F001-76-500A	1		
	76 509D	COVER, BEARING	8871-76-509	1		
	76 510	SPRING	8871-76-510	1		
	76 511C	BALL, STEEL	8871-76-511	1		
	76 512E	COVER, BEARING	8871-76-512	1		
	76 513C	SPACER	8871-76-513	1		
	76 514C	BALL, STEEL	8871-76-514	1		
	76 516	WASHER	8871-76-517	1		
	76 518	PIN	8871-76-515	1		
	76 521	WIRE, HEATER CONTROL	8871-76-505	1		
	76 522	WIRE, HEATER CONTROL	8341-76-506	1		
	76 523	WIRE, HEATER CONTROL	8871-76-507	1		

6120A-1 HEATER BLOWER

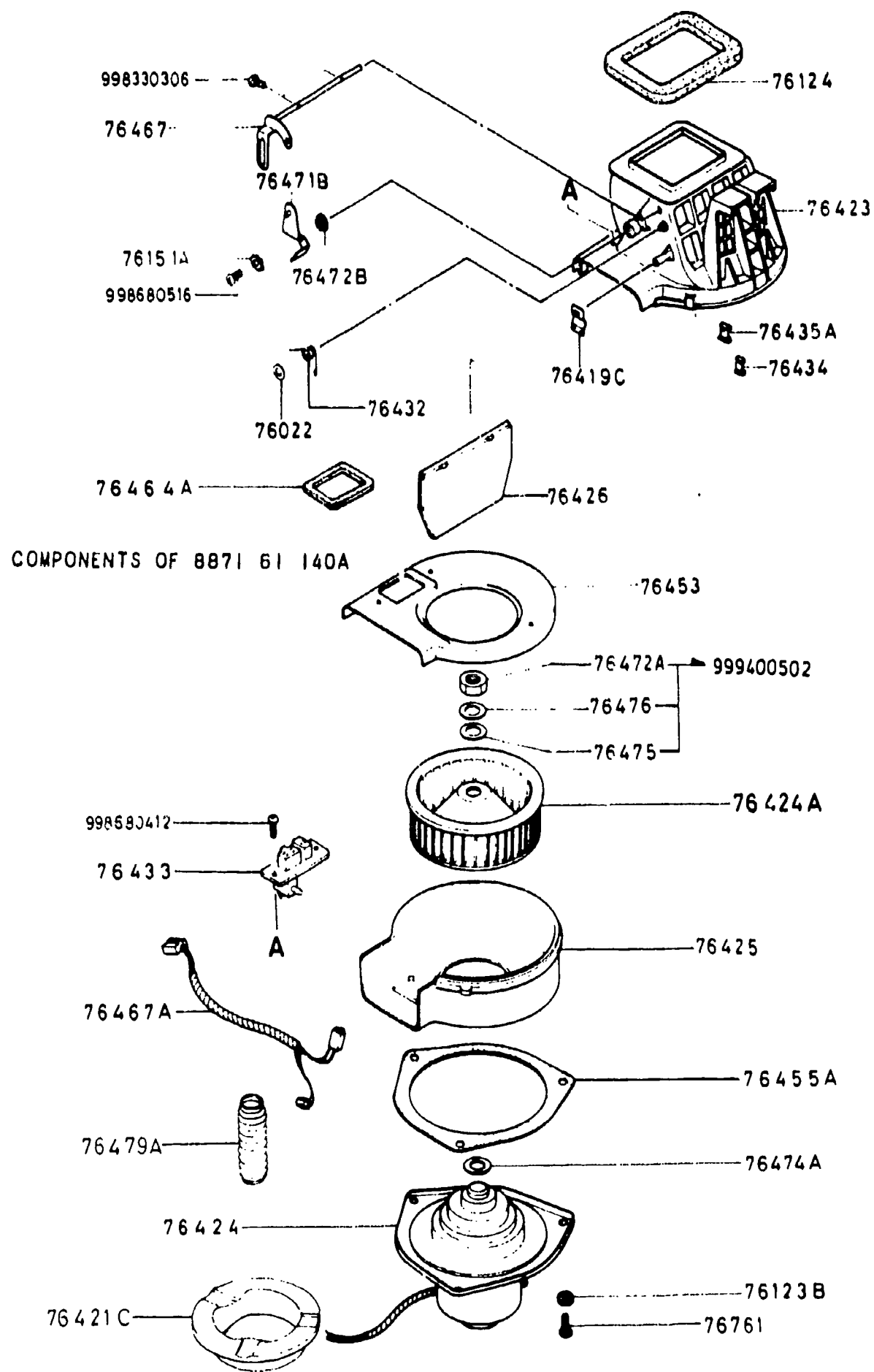

ITEM NO.	D-CODE	DESCRIPTION	PART NO.	QTY	MODEL/DESCRIPTION	REMARKS
	76 022	WASHER	8871-76-469	1		
	76 123B	BUSHING	8871-76-470	1		
	76 124	PACKING	8871-76-465	1		
	76 151A	SPRING	8871-76-461	1		
	76 419C	CLIP	8871-76-464	1		
	76 421C	COVER, MOTOR	8871-76-478	1		
	76 423	CASE, FAN	8871-76-450	1		
	76 424	MOTOR, FAN	8871-76-453A	1		
	76 424A	MOTOR, FAN	8871-76-456	1		
	76 425	CASE	8871-76-451	1		
	76 426	SHUTTER	8071-76-459	1		
	76 432	SPRING, CONTROL LEVER	8871-76-463	1		
	76 433	RESISTOR	8871-76-457	1		
	76 434	CLIP	8871-76-466	4		
	76 435A	CLIP	8871-76-471	1		
	76 453	FLANGE	8871-76-452	1		
	76 455A	GASKET	8871-76-454	1		
	76 464A	GASKET	8871-76-458	1		
	76 467	SHAFT	8871-76-468	1		
	76 467A	WIRING, BLOWER	8871-76-467A	1		
	76 471B	LEVER, CONTROL	8871-76-460	1		
	76 472A	NUT	3794-76-426	1	'81 & '82 MODELS	FB331 ..500001-618727
	76 472B	COLLAR	8871-76-462	1		
	76 474A	WASHER, PLAIN	0866-76-471	1		
	76 475	WASHER, PLAIN	0866-76-475	1	'81 & '82 MODELS	FB331 ..500001-618727
	76 476	WASHER, PLAIN	0866-76-476	1	'81 & '82 MODELS	FB331 ..500001-618727
	76 479A	HOSE	8871-76-479	1		
	76 761	SCREW	8871-76-455	3		

6132A-1 CONDENSER PACKAGE ('81 MODEL)

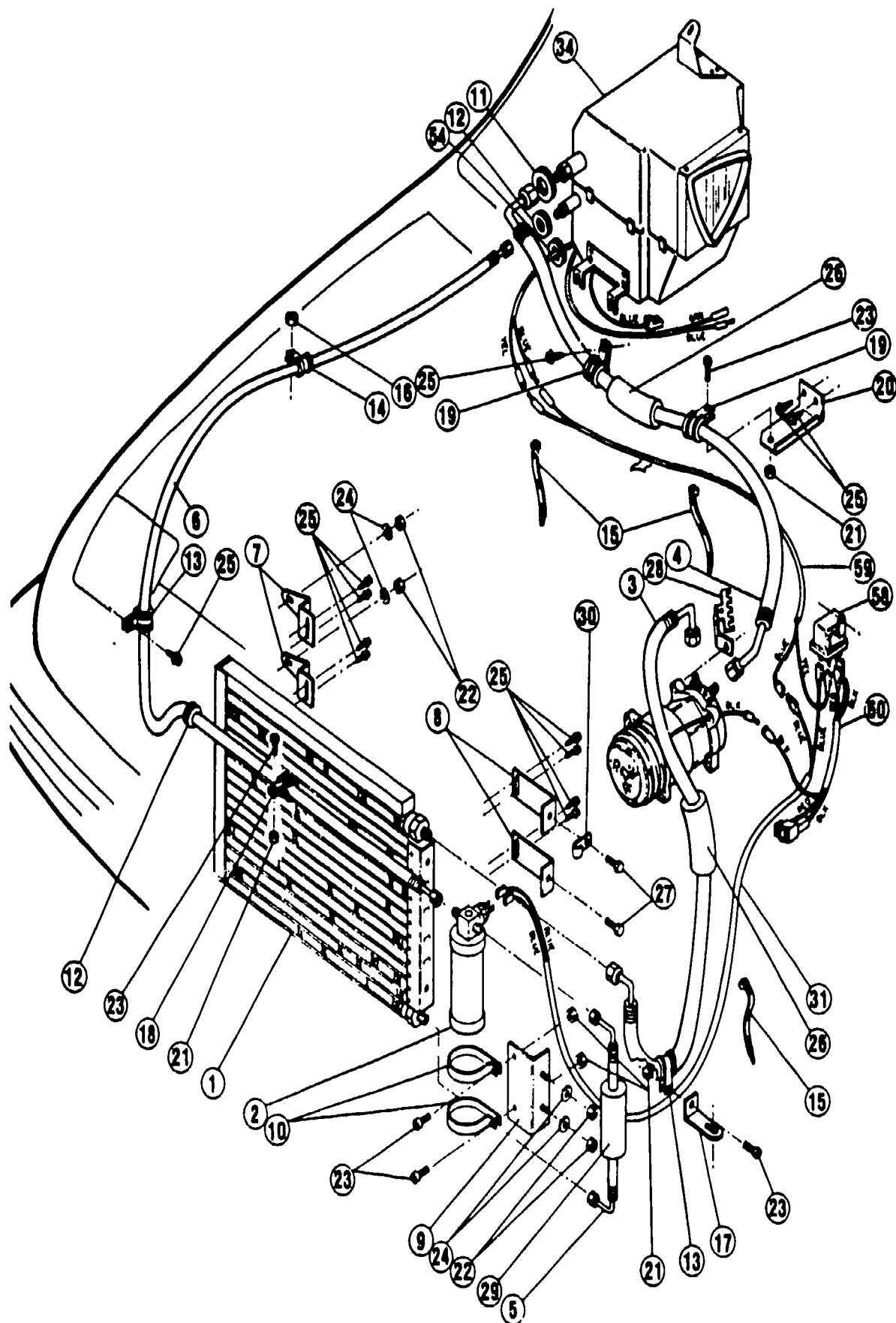

ITEM NO.	D-CODE	DESCRIPTION	PART NO.	QTY	MODEL/DESCRIPTION	REMARKS
1		CONDENSER	0000-67-1265-57	1		
2		RECEIVER-DRIER	0000-67-0440-49	1	W/ 0000-67-0957-80, LOW PRESSURE SWITCH	
3		HOSE, DISCHARGE	0000-67-0651-46	1	(COMP.-CONDENSER) 1/2F 90 X 1/2F 90 X 41 (0 DEG. ORIENTATION)	
4		HOSE, SUCTION	0000-67-0651-47	1	(EVAPORATOR- COMPRESSOR) 5/8F 110 X 5/8F PREFORMED END X 38 1/2	
5		HOSE, LIQUID	0000-67-0651-48	1	(COND.-REC./DRIER) 3/8F 90 X 3/8F 90 X 18 (0 DEG. ORIENTATION)	
6			0000-67-0651-49	1	(RECEIVER/DRIER- EVAPORATOR) 3/8F X 3/8F X 66	
7		SACK KIT, CONDENSER	0000-67-1477-21			
8		BRACKET (R), CONDENSER	0000-67-0007-44	2		
9		BRACKET (L), CONDENSER	0000-67-0007-45	2		
10		BRACKET, MOUNTING-REC/ DRIER	0000-67-0011-83	1		
11		CLAMPS, RECEIVER/DRIER	0000-67-0000-33	2		
12		GROMMET	0000-67-A43A-6F	1		
13			0000-67-A44A-6F	2		
14		CLAMP NO. 6, HOSE	0000-67-1998-14	2		
15			0000-67-1998-13	1	W/LARGE HOLE	
16		TY-RAP	0000-67-X60A-00	4		
17		NUT, HEX	0000-67-1981-86	1	8MM	
18		CLAMP, HOSE	0000-67-1970-62	1	STAND-OFF BRACKET, 90 DEG. TO FENDER WELL	
19			0000-67-A46A-3F	1		
20		CLAMP NO. 8, HOSE	0000-67-1998-16	2		
21		CLAMP, HOSE	0000-67-0011-62	1	STAND-OFF BRACKET, 90 DEG. TO FIREWALL	
22		NUT, KEPS	0000-67-1997-59	5	ZINC, NO. 10 X 32	
23			0000-67-1982-33	4	ZINC, 1/4 X 20	
24		SCREW, MACHINE	0000-67-1997-24	5	ZINC, NO. 10-32 X 1-2 PH	
25		FLATWASHER	0000-67-0402-83	4	ZINC, 1/4	
26		SCREW, TAPPING	0000-67-X30A-01	12	NO. 10 X 1-2	
27		PROTECTOR, HOSE	0000-67-1977-07	2	4	
28		BOLT, HEX	0000-67-1997-27	2	1/4-20 X 1 2	
29		CORD CLIP ASSEMBLY, HIGH TENSION	0000-67-1978-35	1		

6132A-2 CONDENSER PACKAGE ('81 MODEL)

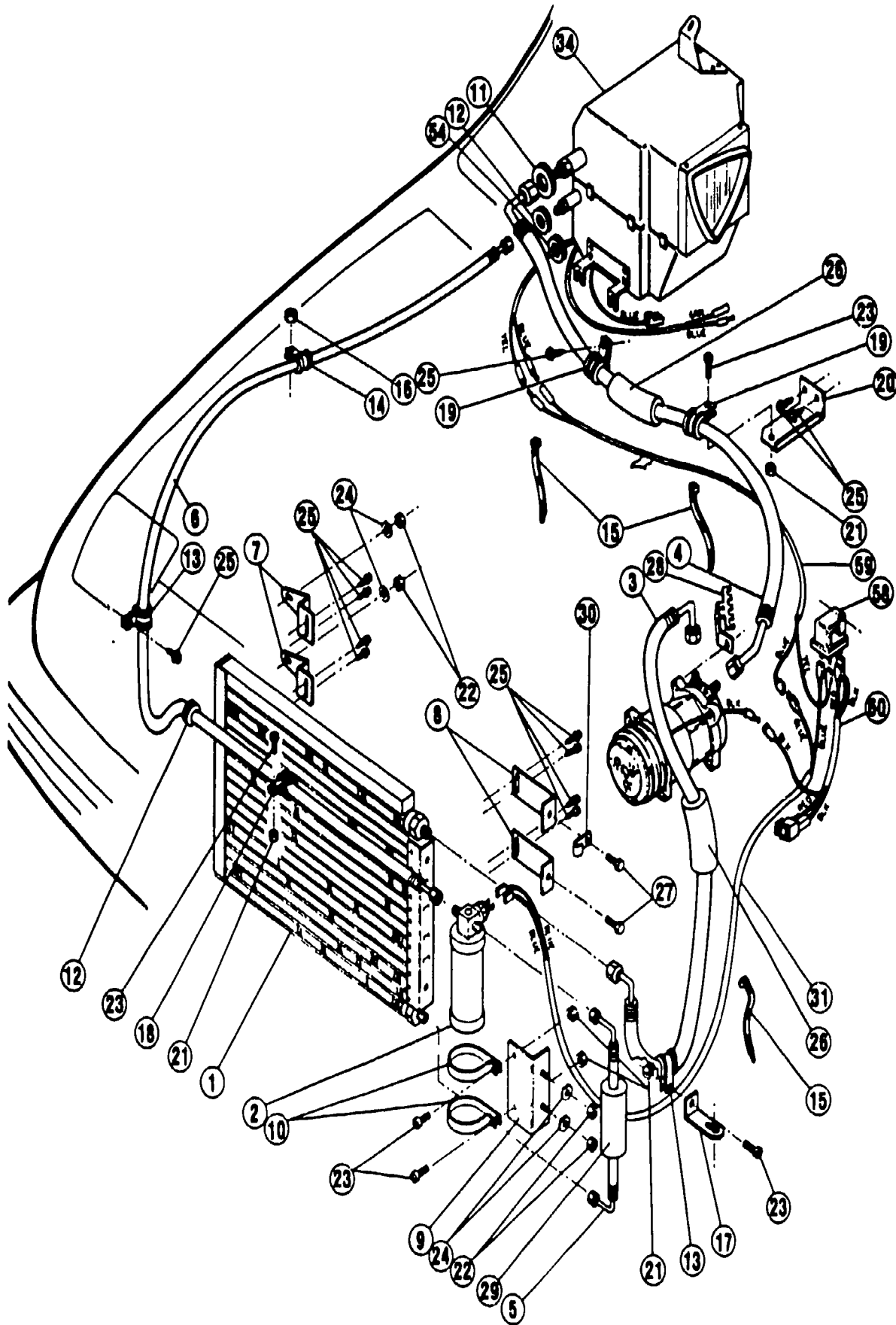

ITEM NO.	D-CODE	DESCRIPTION	PART NO.	QTY	MODEL/DESCRIPTION	REMARKS
29		PROTECTOR, HOSE	0000-67-1977-09	1	6	
30		CLAMP, WIRE HARNESS	0000-67-1977-89	1		
31		HARNESS, WIRE	0000-67-1977-99			

6132AB-1 CONDENSER PACKAGE ('82 MODEL)

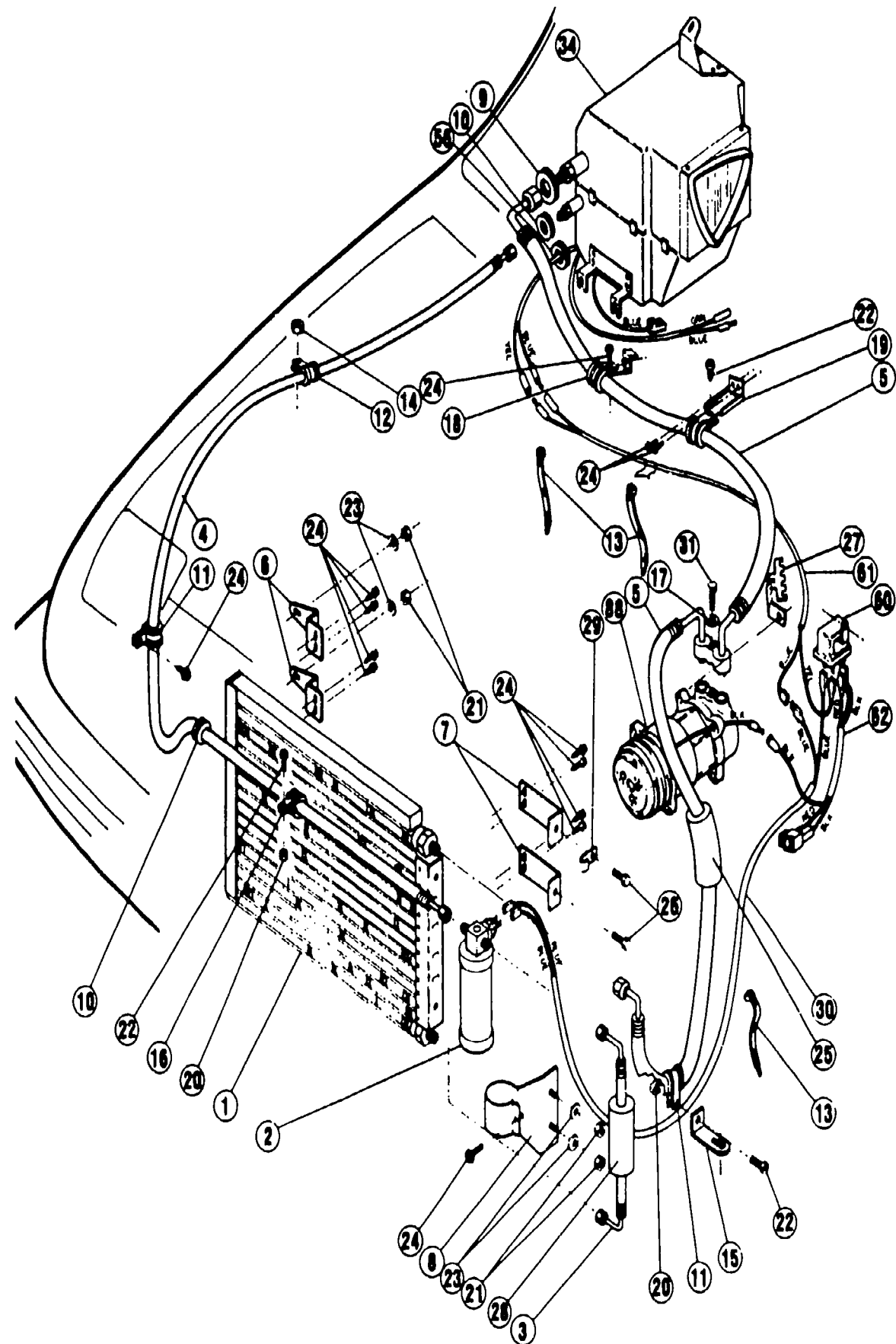

ITEM NO.	D-CODE	DESCRIPTION	PART NO.	QTY	MODEL/DESCRIPTION	REMARKS
1		CONDENSER	0000-67-1285-08	1		
2		RECEIVER-DRIER	0000-67-0440-53	1	W/ 0000-67-A93A-3F, SLOW PRESSURE SWITCH	
3		HOSE, LIQUID	0000-67-0652-70	1	(COND.-REC./DRIER) 3/8 O-RING 90 DEG. X 3/8 O-RING 90 DEG. X 18	
4			0000-67-0652-71	1	(RECEIVER/DRIER-EVAPORATOR) 3/8 O-RING X 3/8 O-RING X 66	
5		HOSE ASSEMBLY	0000-67-1970-27	1	SUCTION-DISCHARGE W/ TUBE BLOCK 0000-67-1978-02	
6		CONDENSER SACK KIT	0000-67-1478-05	1		
7		BRACKET (R), CONDENSER	0000-67-0007-44	2		
8		BRACKET (L), CONDENSER	0000-67-0007-45	2		
9		BRACKET, MOUNTING-RECEIVER/DRIER	0000-67-0011-83	1		
10		GROMMET	0000-67-A43A-6F	1		
11		GROMMET	0000-67-A44A-6F	2		
12		CLAMP NO. 6, HOSE	0000-67-1998-14	2		
13		CLAMP NO. 6, HOSE	0000-67-1998-13	1	W/ LARGE HOLE	
14		TY-RAP	0000-67-X60A-00	4		
15		NUT, HEX	0000-67-1981-86	1	8MM	
16		CLAMP, HOSE	0000-67-0007-47	1	STAND-OFF BRACKET 90 DEG. TO FENDER WELL	
17		CLAMP NO. 8, HOSE	0000-67-A46A-3F	1		
18		FLATWASHER	0000-67-1983-82	1	10MM X 0.82 OD	
19		CLAMP, BRACKET, HOSE	0000-67-0011-61	1	RIGHT FIREWALL	
20		CLAMP, BRACKET, HOSE	0000-67-0011-62	1	LEFT FIREWALL	
21		NUT, KEPS	0000-67-1997-59	3	ZINC, NO. 10-32	
22		NUT, KEPS	0000-67-1982-33	4	ZINC, 1-4-20	
23		SCREW, MACHINE	0000-67-1997-24	3	ZINC, NO. 10-32 X 1 2 PH	
24		FLATWASHER	0000-67-0402-83	4	ZINC, 1-4	
25		SCREW, TAPPING	0000-67-X30A-01	14	NO. 10 X 1-2	
26		PROTECTOR, HOSE	0000-67-1977-07	1	4	
27		BOLT, HEX	0000-67-1997-27	2	1 4-20 X 1 2	
28		CORD CLIP ASSEMBLY, HIGH TENSION	0000-67-1978-35	1		
29		PROTECTOR, HOSE	0000-67-1977-09	1	6	
30		CLAMP, WIRE HARNESS	0000-67-1977-89	1		
31		HARNESS, WIRE	0000-67-1977-99	1		

6132AB-2 CONDENSER PACKAGE ('82 MODEL)

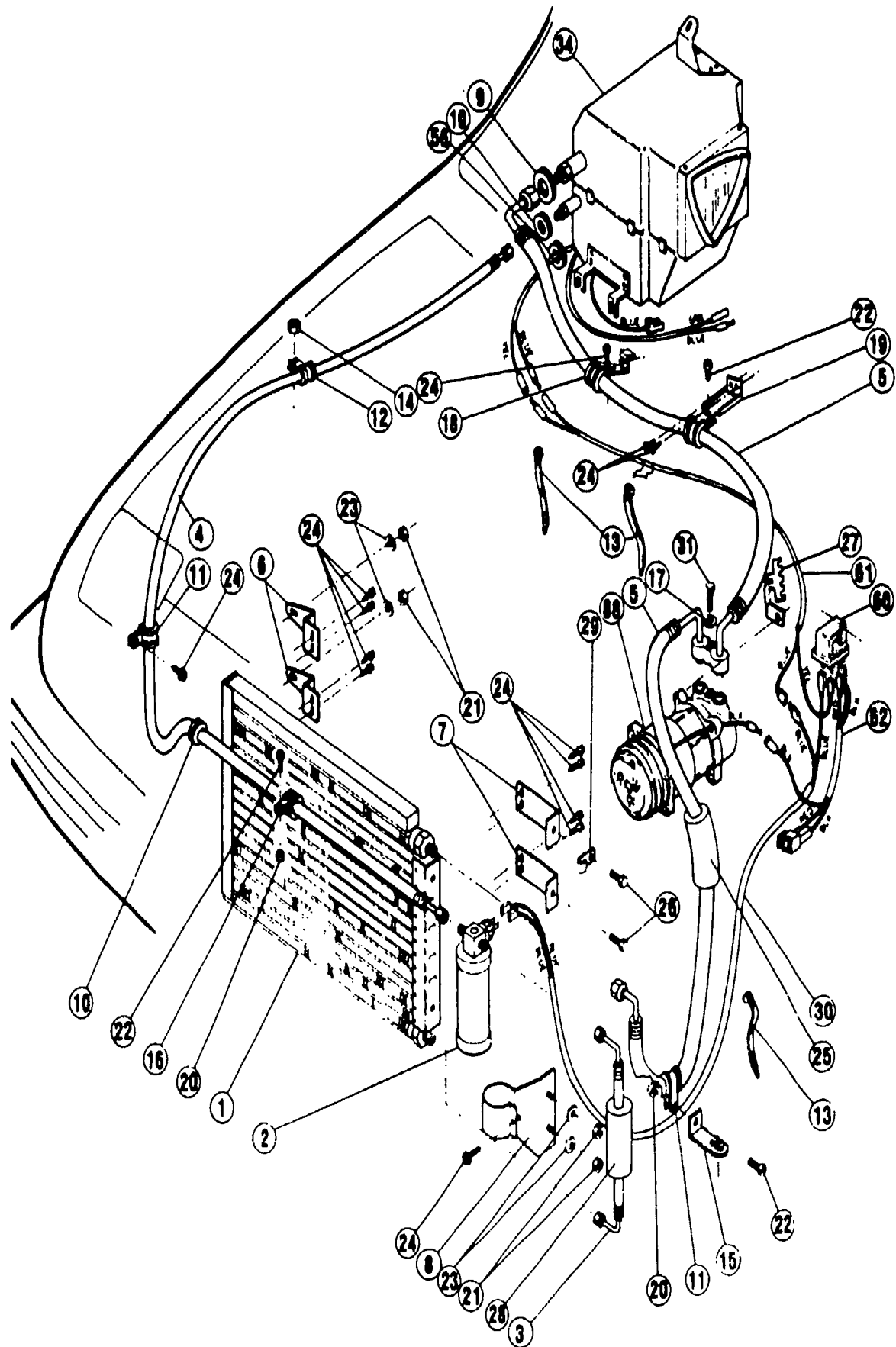

ITEM NO.	D-CODE	DESCRIPTION	PART NO.	QTY	MODEL/DESCRIPTION	REMARKS
31		BOLT	0000-67-6716-50	1	10MM-1.00 X 35MM	
		O-RING PACKAGE SET	0000-67-0123-38	1	FOR HOSE & COMPRESSOR FITTING	

SECTION INDEX -- BODY

STARTING LOCATION	SECT. NO.	SECTION NAME	STARTING LOCATION	SECT. NO.	SECTION NAME	STARTING LOCATION	SECT. NO.	SECTION NAME
2 - C 3	0900A	KEY SETS	2 - E 8	6142A	COMPRESSOR MOUNTING KIT, COMPRESSOR/CLUTCH ASSEMBLY & REPAIR PARTS ('81 MODEL)	2 - H 11	6870A	SERVICE TOOLS
2 - D 3	5000A	FRONT BUMPER	2 - F 8	6142AB	COMPRESSOR MOUNTING KIT, COMPRESSOR/CLUTCH ASSEMBLY & REPAIR PARTS ('82 MODEL)	2 - I 11	6900A	VISOR, ASSIST HANDLE & MIRRORS
2 - E 3	5005A	RADIATOR GRILLE	2 - G 8	6142AC	COMPRESSOR MOUNTING KIT, COMPRESSOR/CLUTCH ASSEMBLY & REPAIR PARTS ('83 MODEL)	2 - L 11	6930A	CAUTION PLATES
2 - F 3	5010A	REAR BUMPER	2 - H 8	6152A	EVAPORATOR PACKAGE ('81 MODEL)			
2 - G 3	5030A	WINDOW MOULDINGS	2 - I 8	6152AB	EVAPORATOR PACKAGE ('82 MODEL)			
2 - H 3	5040A	BODY MOULDINGS	2 - J 8	6152AC	EVAPORATOR PACKAGE ('83 MODEL)			
2 - I 3	5060A	SIDE PROTECTORS	2 - K 8	6230A	BACK DOOR MECHANISM			
2 - J 3	5100A	HEAD LAMPS	2 - L 8	6300A	WINDOW GLASSES			
2 - K 3	5103A	HEAD LAMP RETRACTORS	2 - M 8	6330A	SUNROOF (GSI)			
2 - L 3	5105A	FRONT COMBINATION & SIDE TURN LAMPS	2 - N 8	6600A	SWITCH & RELAY (ENGINE & TRANSMISSION)			
2 - M 3	5110A	REAR COMBINATION LAMPS						
2 - N 3	5120A	LICENSE & REAR SIDE TURN LAMPS						
2 - C 4	5125A	INTERIOR LAMPS (GS & GSI)						
2 - D 4	5170A	ORNAMENTS						
2 - E 4	5180A	COWL & EXTRACTOR GRILLES						
2 - F 4	5230A	HOOD	2 - C 9	6610A	DASHBOARD SWITCHES (MANUAL OPERATING)			
2 - G 4	5310A	BODY PANELS (FRONT)	2 - D 9	6611A	COMBINATION SWITCH			
2 - I 4	5340A	BODY PANELS (SIDE & ROOF)	2 - E 9	6615A	POWER WINDOW SWITCH			
2 - J 4	5360A	BODY PANELS (FLOOR)	2 - F 9	6620A	DOOR, PARKING LAMP & KICK DOWN SWITCH			
2 - K 4	5370A	FLOOR ATTACHMENTS	2 - G 9	6630A	RELAY (BODY)			
2 - L 4	5500A	DASHBOARD EQUIPMENT	2 - H 9	6635A	HORN			
2 - N 4	5540A	METERS	2 - I 9	6640A	AUTO CRUISE CONTROL			
2 - C 5	5560A	DASHBOARD & RELATED	2 - J 9	6680A	AUDIO SYSTEM			
2 - E 5	5570A	CONSOLE	2 - M 9	6700A	WIRE HARNESS (FRONT & REAR)			
2 - G 5	5580A	VENTILATOR	2 - N 9	6701A	WIRE HARNESS (ENGINE & TRANSMISSION)			
2 - H 5	5700A	SEATS ('81 & '82) MODELS	2 - C 10	6702A	WIRE HARNESS (DASHBOARD)			
2 - C 6	5700AA	SEATS ('83 MODEL)	2 - D 10	6703A	WIRE HARNESS (DOOR, FLOOR & CEILING)			
2 - H 6	5790A	SEAT BELTS	2 - E 10	6704A	WIRE HARNESS CLAMPS			
2 - J 6	5800A	FRONT DOOR	2 - F 10	6720A	WINDSHIELD WASHER			
2 - K 6	5830A	FRONT DOOR MECHANISM	2 - G 10	6730A	WINDSHIELD WIPER			
2 - C 7	5840A	FRONT DOOR TRIM & RELATED PARTS	2 - H 10	6740A	WIPER MOTOR (COMPONENTS ONLY)			
2 - F 7	6100A	HEATER	2 - I 10	6750A	REAR WINDOW WIPER & WASHER			
2 - G 7	6110A	HEATER UNIT	2 - J 10	6760A	REAR WINDOW WIPER MOTOR (COMPONENTS ONLY)			
2 - H 7	6115A	HEATER CONTROLS	2 - K 10	6800A	CEILING TRIM			
2 - I 7	6120A	HEATER BLOWER	2 - C 11	6840A	TRIM & SCUFF PLATE			
2 - J 7	6132A	CONDENSER PACKAGE ('81 MODEL)	2 - F 11	6860A	FLOOR MATS & PADS			
2 - L 7	6132AB	CONDENSER PACKAGE ('82 MODEL)						
2 - C 8	6132AC	CONDENSER PACKAGE ('83 MODEL)						

6132AC-1 CONDENSER PACKAGE ('83 MODEL)

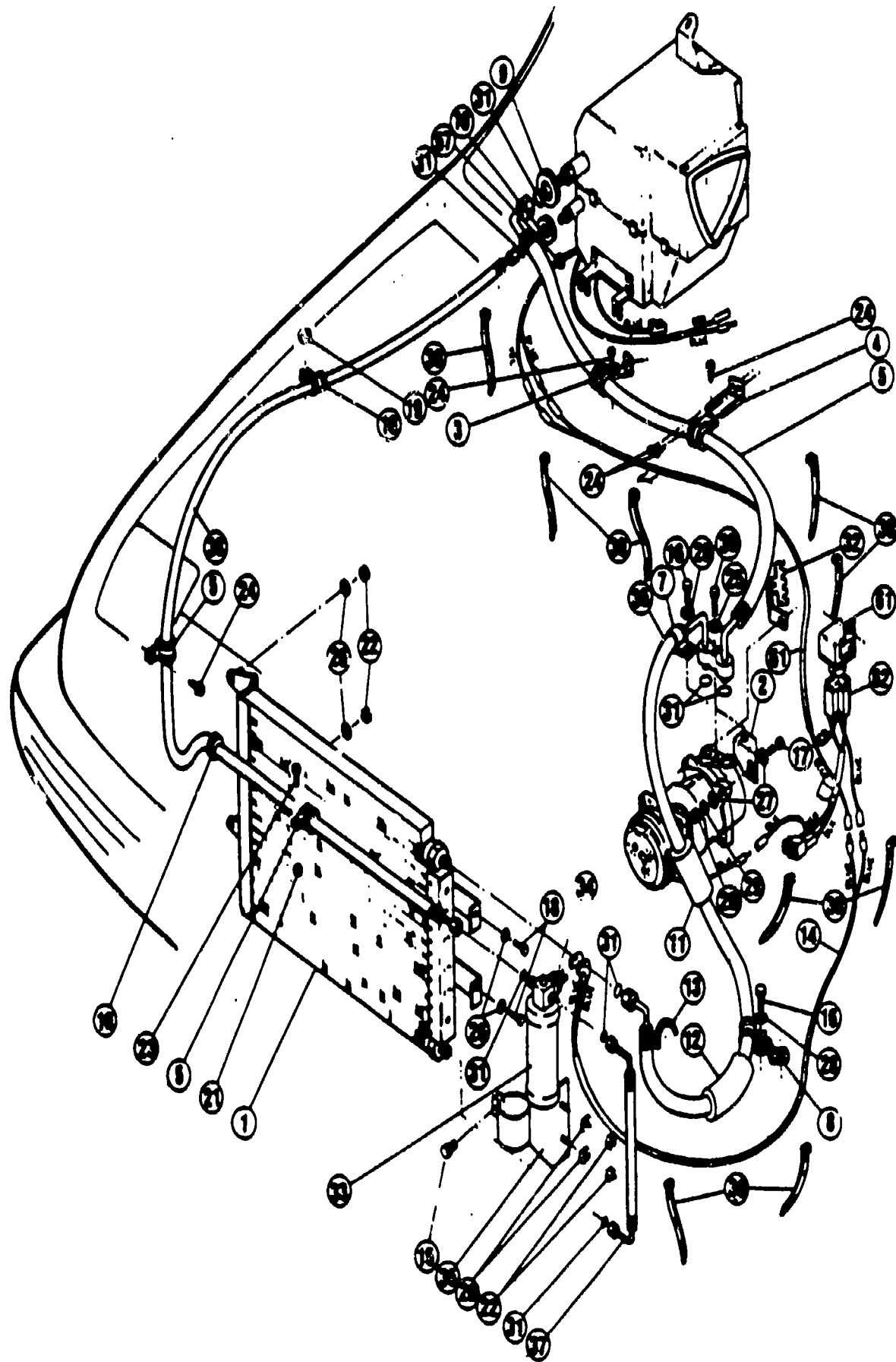

ITEM NO.	D-CODE	DESCRIPTION	PART NO.	QTY	MODEL/DESCRIPTION	REMARKS
1		CONDENSER ASSEMBLY	0000-67-1285-08	1		
2		SACK KIT, CONDENSER	0000-67-A20A-3A	1		
2		BRACKET, HOSE CLAMP	0000-67-0012-72	1		
3			0000-67-0011-61	1		
4			0000-67-0011-62	1		
5		CLAMP NO. 6, HOSE	0000-67-1998-14	2		
6			0000-67-1998-13	1	W/ LARGE HOLE	
7		CLAMP, HOSE	0000-67-1970-63	1		
8			0000-67-1970-62	1		
9		GROMMET	0000-67-A43A-6F	1		
10			0000-37-A44A-6F	2		
11		PROTECTOR, HOSE	0000-67-1977-07	1	4	
12			0000-67-1977-09	1	6	
13			0000-67-A50A-3A	1	EDGE TRIM, 2.8	
14		HARNES, WIRE	0000-67-1977-99	1		
15		BOLT, HEX	0000-67-1997-16	1	ZINC, 6MM X 20MM	
16			0000-67-1997-86	2	ZINC, 6MM X 16MM	
17			0000-67-6715-56	1	10MM X 1.5 X 30MM-14MM	
18			0000-67-1997-27	2	1/4 X 20 1/2	
19		NUT, HEX	0000-67-1981-86	1	8MM X 1.25	
20			0000-67-1981-82	1	10MM X 1.5	
21		NUT, KEPS	0000-67-1997-57	1	ZINC, NO. 10-32	
22			0000-67-1982-33	4	ZINC, 1/4-20	
23		SCREW	0000-67-1997-24	1	ZINC, NO. 10-32 X 1/2 PH	
24		SCREW, TAPPING	0000-67-X30A-01	5	ZINC, NO. 10 X 1/2 HWH	
25		FLATWASHER	0000-67-1983-82	1	ZINC, 10MM W/ 0.708 OD	
26			0000-67-0402-83	6	ZINC, 1/4	
27			0000-67-1981-83	2	ZINC, 10MM	
28		LOCKWASHER	0000-67-X40M-04	2	6MM	
29			0000-67-X40M-03	1	10MM	
30		TY-RAP	0000-67-X60A-00	9	6	
31		O-RING PACKAGE SET	0000-67-0123-38	1	SET FOR HOSE & COMPRESSOR	
32		CORD CLIP ASSEMBLY, HIGH TENSION	0000-67-1478-35	1		
		RECEIVER-DRIER ASSEMBLY	0000-67-0440-53	1		
33		RECEIVER-DRIER	0000-67-A90A-3A	1		
34		SWITCH, LOW-PRESSURE CUT-OFF	0000-67-A93A-3F	1		

6132A.C-2 CONDENSER PACKAGE ('83 MODEL)

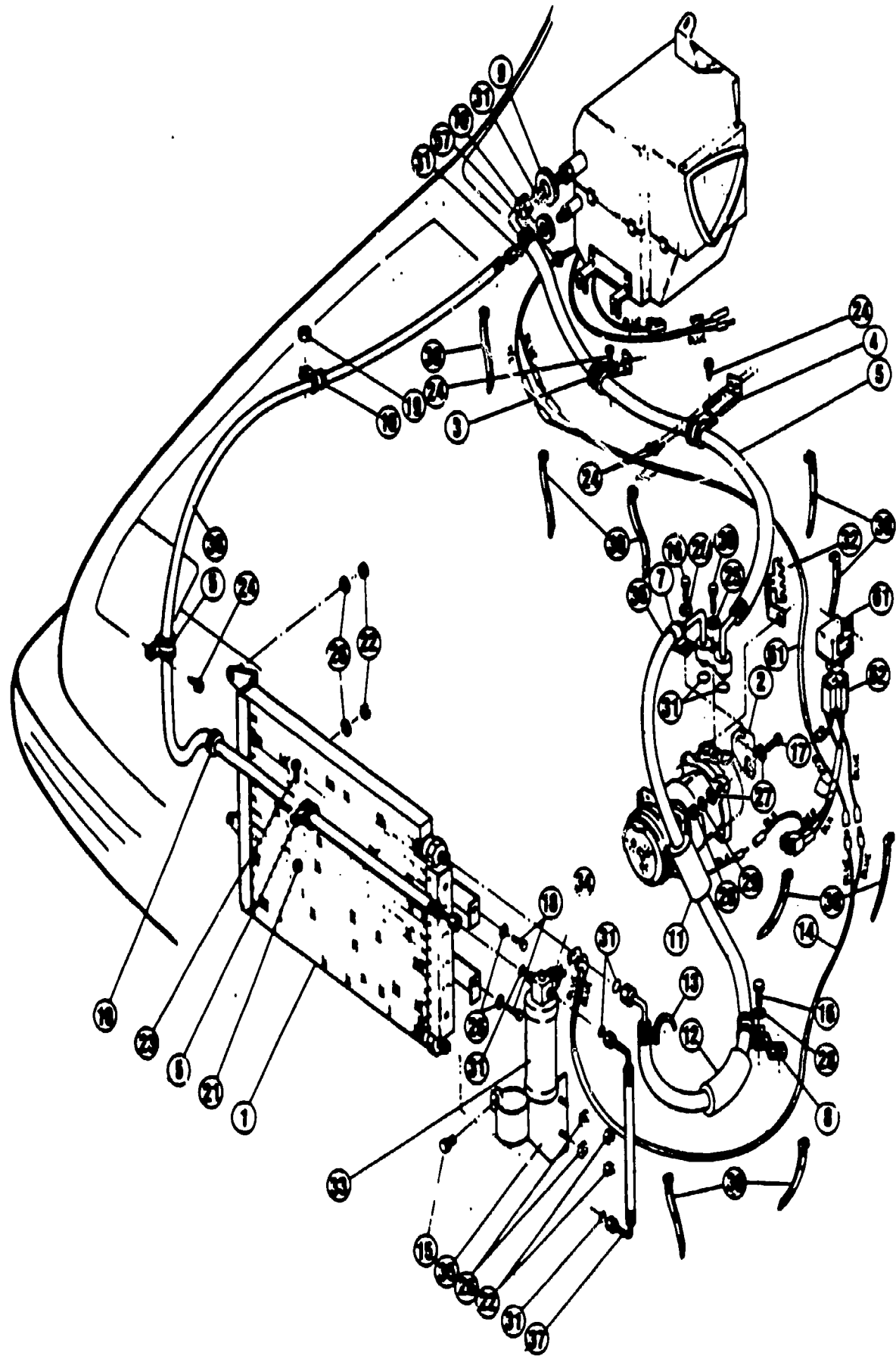

ITEM NO.	D-CODE	DESCRIPTION	PART NO.	QTY	MODEL/DESCRIPTION	REMARKS
35		BRACKET, RECEIVER-DRIER	0000-67-0011-83	1		
36		HOSE BLOCK ASSEMBLY	0000-67-1970-27	1	DISCHARGE-SUCTION	
37		HOSE, LIQUID	0000-67-0632-70	1	(COMP.-REC./DRIER) 3/8 O-RING 90 DEG. X 3/8 O-RING 90 DEG. X 18	
38			0000-67-0652-71	1	(RECEIVER/DRIER- EVAPORATOR) 3/8 O-RING X 3/8 O- RING X 66	
39		BOLT, COMPRESSOR	0000-67-6716-50	1	10MM X 1.00 X 35MM	

6142A-1 COMPRESSOR MOUNTING KIT, COMPRESSOR/CLUTCH ASSEMBLY & REPAIR PARTS ('81 MODEL)

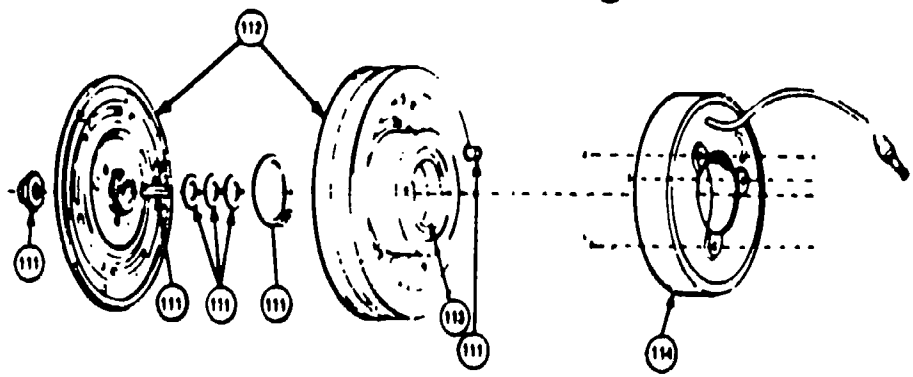
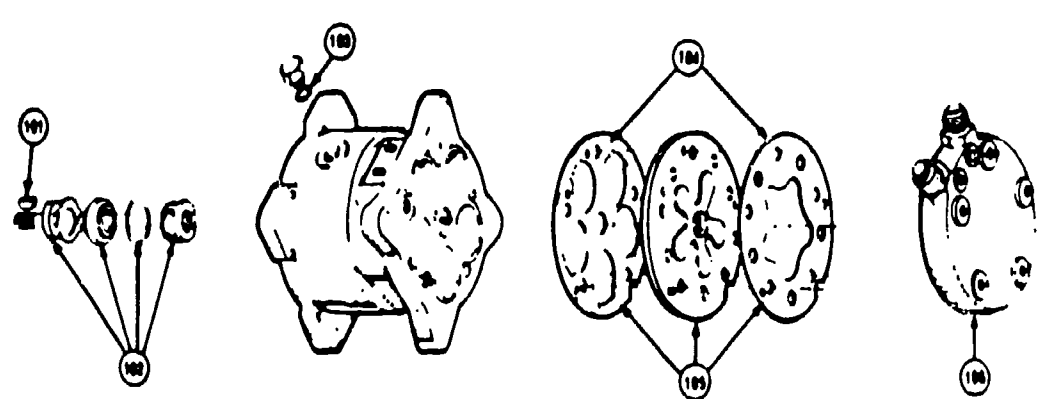
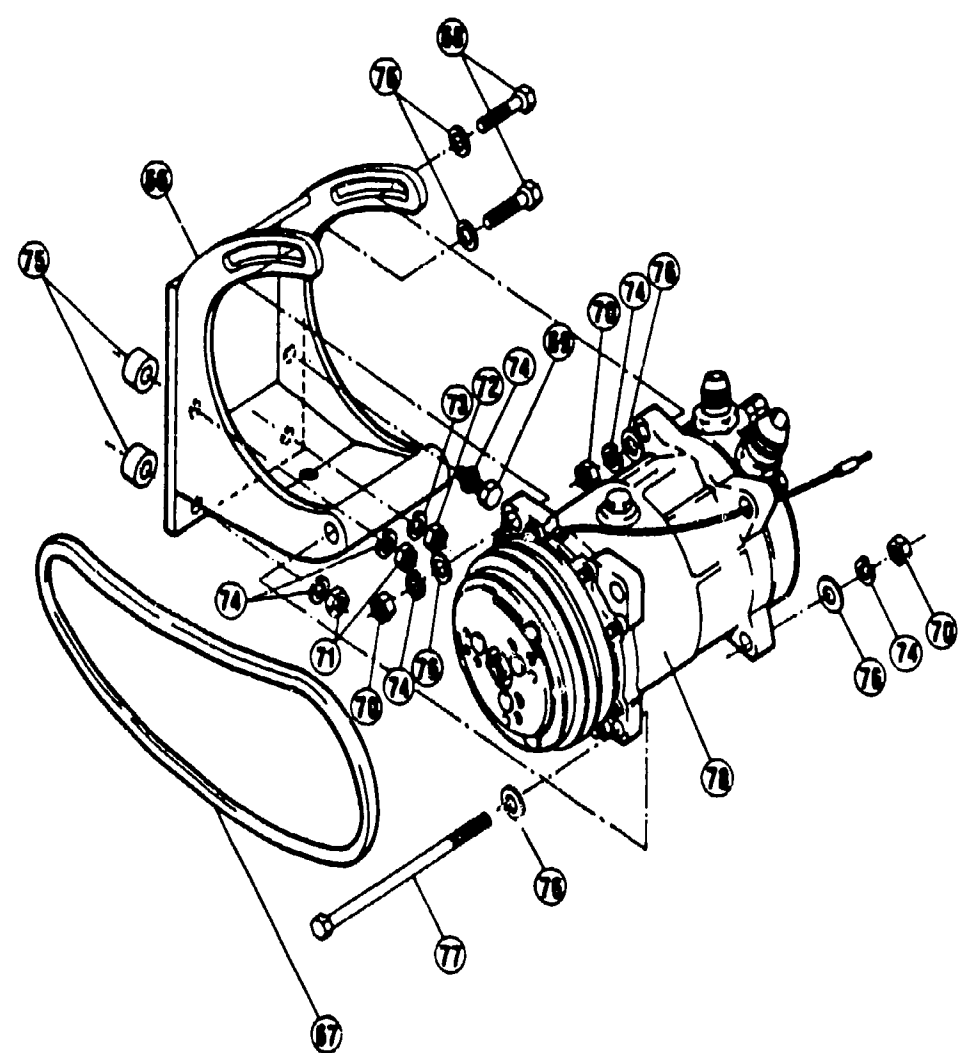

ITEM NO.	D-CODE	DESCRIPTION	PART NO.	QTY	MODEL/DESCRIPTION	REMARKS
		ADAPTER KIT	0000-67-0052-34	1	USE W/ 0000-67-0070-99 COMPRESSOR/CLUTCH	
66		BRACKET, MOUNTING- COMPRESSOR	0000-67-5234-01	1		
67		BELT, DRIVE	0000-67-C31A-6A	1	(436)	
		BOLT SACK KIT	0000-67-5234-03	1		
68		BOLT	0000-67-1982-40	1	3/8 X 1 1/2 NC	
69			0000-67-1983-70	1	10MM X 1.25 X 20	
70		NUT	0000-67-1983-77	3	3/8 NC	
71				2	10MM X 1.25	
72			0000-67-1983-76	1	12MM X 1.5	
73		LOCKWASHER	0000-67-X40A-01	1	1/2	
74			9997-11-000	6	10MM	
75		SPACER	0000-67-5234-04	2	3/4 X 7/16 X 3/8	
76		FLATWASHER	0000-67-1983-75	6	3/8 X 1/8	
77		BOLT	0000-67-1983-71	1	3/8 NC X 5 1/2	
		COMPRESSOR/CLUTCH	0000-67-0070-99	1	(SANKYO 8390)	
		COMPRESSOR	0000-67-0070-88	1	(SANKYO 8366) SD 508	
101		KEY, SHAFT	0000-67-D11A-6A	1		
102		SEAL KIT	0000-67-D12A-3B	1		
103		O-RING SET	0000-67-0123-40	1	PACKAGE OF 10	
104		GASKET KIT	0000-67-D13B-3B	1		
105		VALVE PLATE ASSEMBLY	0000-67-D14B-3B	1		
106		HEAD, CYLINDER	0000-67-0127-10	1		
		CLUTCH	0000-67-0229-37	1	5 1/4	
111		ACCESSORY KIT	0000-67-1410-13	1		
112		FRONT PLATE & RECEIVER	0000-67-0233-37	1		
113		BEARING	0000-67-D23A-3B	1		
114		COIL, FIELD	0000-67-0232-37	1		

6142AB-1 COMPRESSOR MOUNTING KIT, COMPRESSOR/CLUTCH ASSEMBLY & REPAIR PARTS ('82 MODEL)

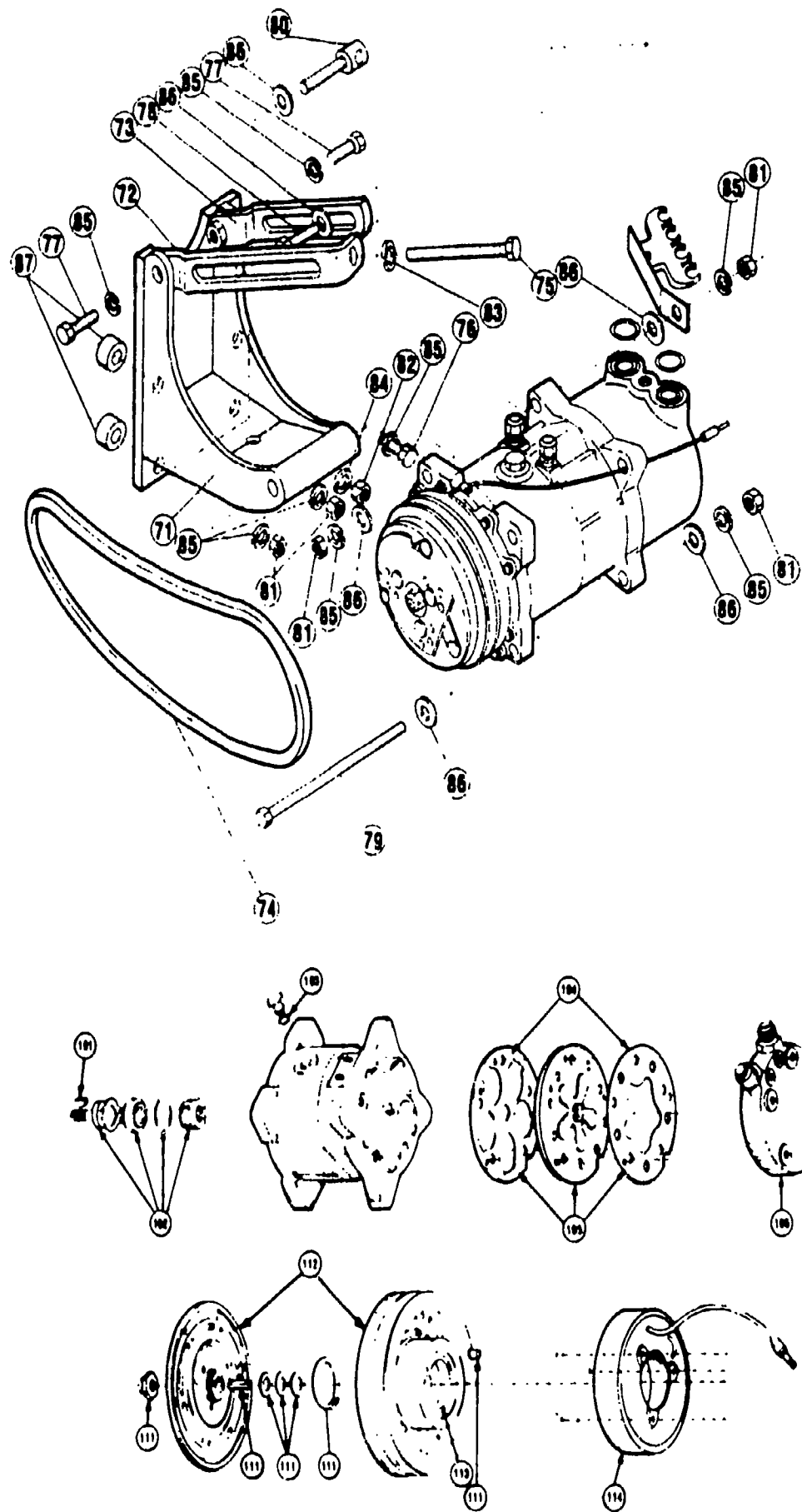

ITEM NO.	D-CODE	DESCRIPTION	PART NO.	QTY	MODEL/DESCRIPTION	REMARKS
		ADAPTER KIT	0000-67-C00A-4A	1	USE W/ 0000-67-D00B-3A	
71		MOUNTING, COMPRESSOR	0000-67-C10A-4A	1		
72		ARM, ADJUSTING-FRONT	0000-67-C21A-4A	1	W/ 90	
73		ARM, ADJUSTING-REAR	0000-67-C22A-4A	1	FLAT	
74		BELT, DRIVE	0000-67-5409-03	1	(17385)	
		BOLT SACK KIT	0000-67-5409-02	1		
75		BOLT, HEX	0000-67-X10M-13	1	8MM-1.25 X 85MM	
76			0000-67-1983-70	1	10MM-1.25 X 20MM	
77			0000-67-1981-79	2	10MM-1.25 X 25MM	
78			0000-67-X10M-25	1	10MM-1.25 X 45MM	
79			0000-67-6716-17	1	10MM-1.25 X 115MM	
80		BOLT	0000-67-X10A-06	1		
81		NUT, HEX	0000-67-1983-77	5	10MM-1.25	
82			0000-67-1983-76	1	12MM-1.50	
83		LOCKWASHER	0000-67-1976-92	1	5/16	
84			0000-67-X40A-01	1	1/2	
85			0000-67-X40M-03	8	10MM	
86		FLATWASHER	0000-67-0970-17	6		
87		SPACER, MOUNTING	0000-67-1983-69	2	3/8 X 3/4 OD-7/16 ID	
		COMPRESSOR/CLUTCH	0000-67-D00B-3A	1	(SANKYO 9157)	
		COMPRESSOR	0000-67-0121-39	1	(SANKYO 1573)	
101		KEY, SHAFT	0000-67-0127-16	1		
102		SEAL KIT	0000-67-0124-26	1		
103		O-RING SET	0000-67-0123-40	1	PACKAGE OF 10	
104		GASKET KIT	0000-67-D13B-3B	1		
105		VALVE PLATE ASSEMBLY	0000-67-D14B-3B	1		
106		HEAD, CYLINDER	0000-67-0127-08	1		
		CLUTCH	0000-67-0229-58	1	5	
111		ACCESSORY KIT	0000-67-0234-00	1		
112		FRONT PLATE & ROTOR	0000-67-0233-15	1		
113		BEARING	0000-67-D23A-6A	1		
114		COIL, FIELD	0000-67-0232-43	1		

6142AC-1 COMPRESSOR MOUNTING KIT, COMPRESSOR/CLUTCH ASSEMBLY & REPAIR PARTS ('83 MODEL)

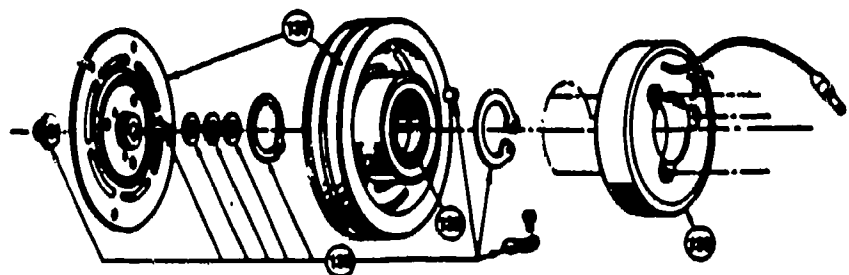
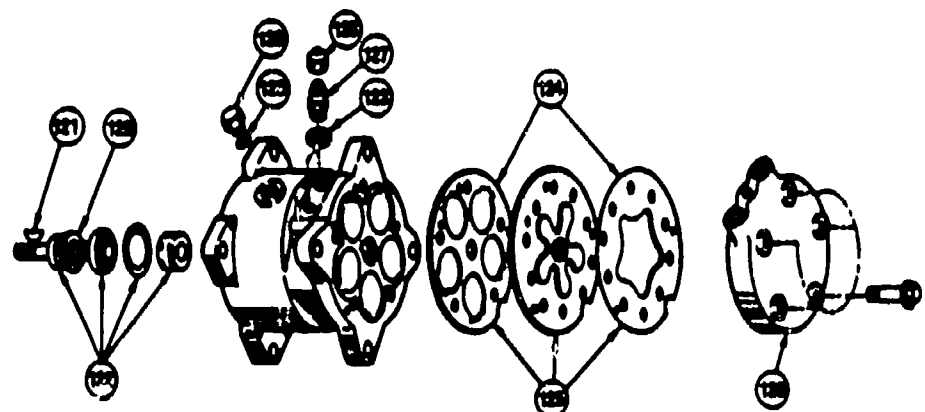
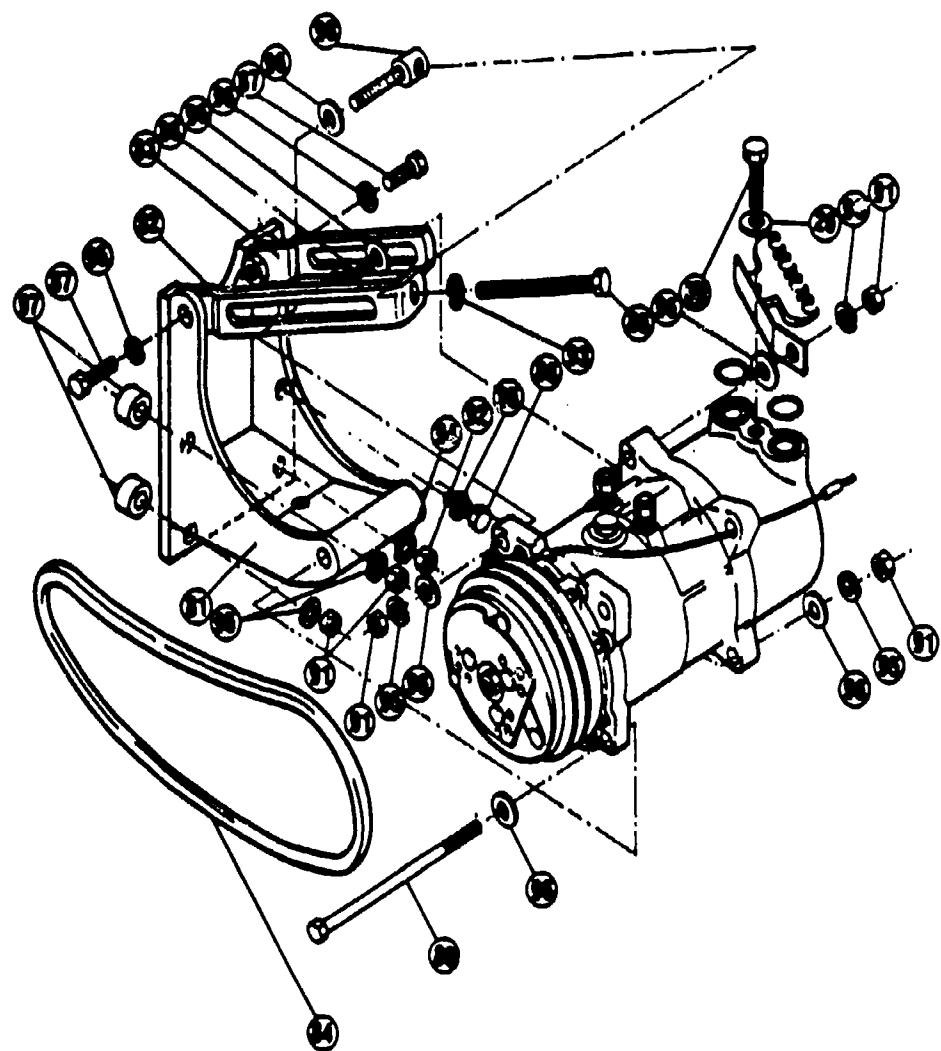

ITEM NO.	D-CODE	DESCRIPTION	PART NO.	QTY	MODEL/DESCRIPTION	REMARKS
		ADAPTER KIT	0000-67-C00A-4A	1	USE W/ 0000-67-D00B-3A COMPRESSOR/CLUTCH	
81		MOUNTING, COMPRESSOR	0000-67-C10A-4A	1		
82		ARM, ADJUSTING-FRONT	0000-67-C21A-4A	1		
83		ARM, ADJUSTING-REAR	0000-67-C22A-4A	1		
84		BELT, DRIVE	0000-67-5409-03	1	(17385)	
		BOLT SACK KIT	0000-67-5409-02	1		
85		BOLT, HEX	0000-67-X10M-13	1	8MM X 1.25 X 85MM	
86			0000-67-1983-70	1	10MM X 1.25 X 20MM	
87			0000-67-1981-79	2	10MM X 1025 X 25MM	
88			0000-67-X10M-25	1	10MM X 1.25 X 40MM	
89			0000-67-6716-17	1	10MM X 1.25 X 120MM	
90		BOLT	0000-67-X10A-06	1	10MM X 45MM W/ 8MM HOLE	
91		NUT, HEX	0000-67-1983-77	1	10MM X 1.25	
92			0000-67-1983-76	1	12MM X 1.5	
93		LOCKWASHER	0000-67-1976-92	1	5/16	
94			0000-67-X40A-01	1	1/2	
95			0000-67-Y40M-03	8	10MM	
96		FLATWASHER	0000-67-0970-17	6	10MM	
97		SPACER, MOUNTING	0000-67-1983-69	2		
		COMPRESSOR/CLUTCH	0000-67-D00B-3A	1	(SANKYO 9165)	
		COMPRESSOR	0000-67-D10A-3A	1	(SANKYO 1653)	
121		KEY, SHAFT	0000-67-D11A-3A	1		
122		SEAL KIT	0000-67-0124-26	1		
123		O-RING SET	0000-67-0123-40	1	PACKAGE OF 10	
124		GASKET KIT	0000-67-D13B-3B	1	GASKET KIT	
125		VALVE PLATE ASSEMBLY	0000-67-D14B-3B	1		
126		HEAD, CYLINDER	0000-67-0127-08	1		
127		PORT, SERVICE	0000-67-D16A-3A	2	W/ VALVE	
128		CAP, SCHRADER VALVE	0000-67-D17A-3A	1	PACKAGE OF 10	
129		RING, SNAP-SEAL SET	0000-67-D18A-3A	1		
130		PLUG, OIL FILLER	0000-67-D19A-3A	1		
		CLUTCH	0000-67-D20A-3A	1	5	
136		ACCESSORY KIT	0000-67-D21A-3A	1		
137		FRONT PLATE & ROTOR	0000-67-D22A-3A	1		
138		BEARING	0000-67-D23A-6A	1		
139		COIL, FIELD	0000-67-D24A-3A	1		

6152A-1 EVAPORATOR PACKAGE ('81 MODEL)

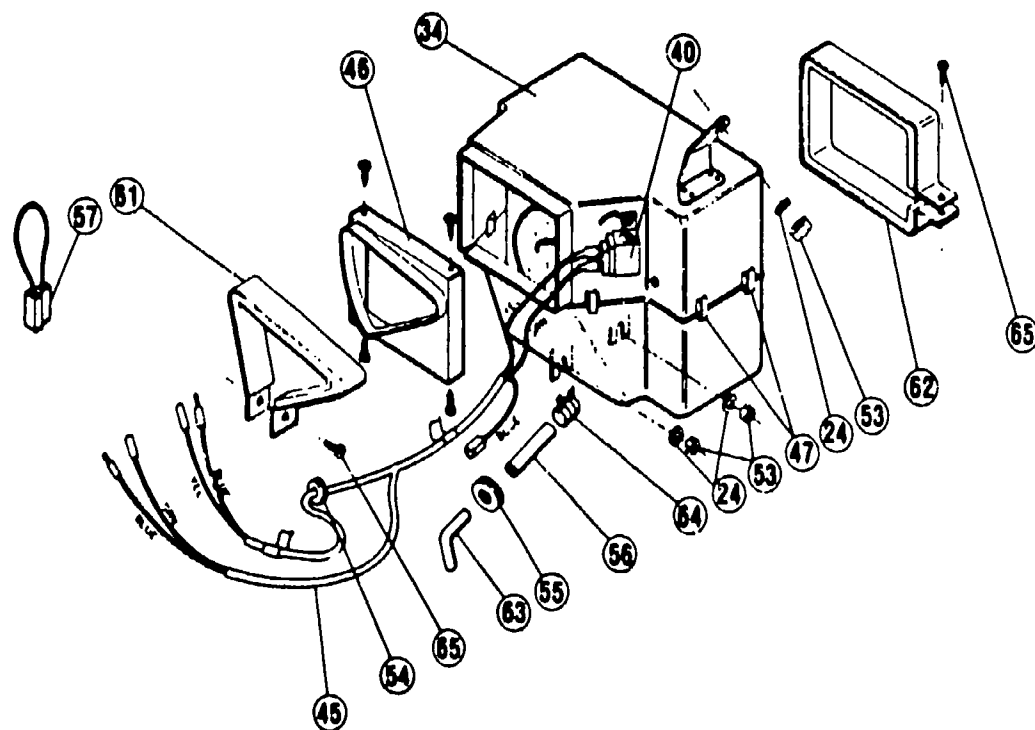
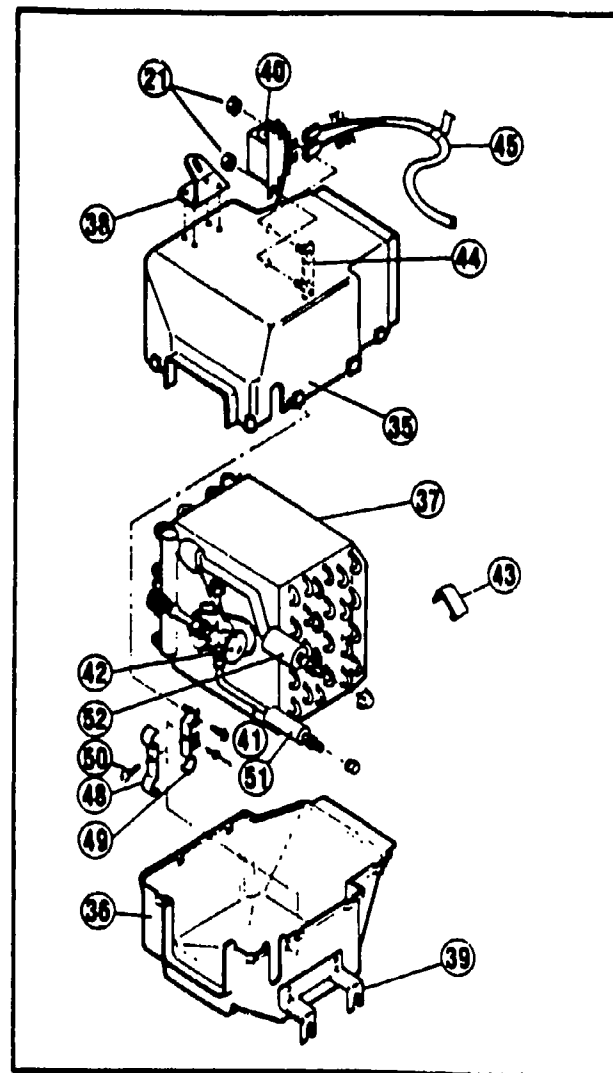

ITEM NO.	D-CODE	DESCRIPTION	PART NO.	QTY	MODEL/DESCRIPTION	REMARKS
34		EVAPORATOR ASSEMBLY	0000-67-2382-79	1		
36		CASE, TOP	0000-67-M00A-3A	1	INJECTION MOULDED	
36		CASE, BOTTOM		1	W/ DRAIN PLATE & DRAIN TUBE	
37		COIL, EVAPORATOR	0000-67-1998-51	1	FOR EXTERIOR EQUALIZED VALVE	
38		BRACKET, CASE-TOP	0000-67-0008-79	1		
39		BRACKET, CASE-BOTTOM	0000-67-M00A-3A	1		
40		SWITCH, THERMOSTAT-PRESET FROSTING	0000-67-0958-17	1		
41		TUBE, ALUMINUM EXTENSION	0000-67-1995-39	1		
42		VALVE, EXPANSION-EXTENSION EQUALIZED	0000-67-0336-80	1		
43		CLAMP NO. 1, BULB	0000-67-B44A-3B	1		
44		BRACKET, MOUNTING-THERMOSTAT	0000-67-0007-37	1		
45		HARNES ASSEMBLY, WIRING	0000-67-1998-49	1		
46		CASE, TRANSITION	0000-67-1977-34	1	INJECTION MOULDED	
47		CLIP, RETAINER	0000-67-1977-25	8		
48		CLIP, EVAPORATOR COIL PIPE	0000-67-0010-63	1		
49			0000-67-0010-64	1		
50		SCREW, TAPPING	0000-67-1982-26	1	NO. 10 X 1/2 PH	
51		PROTECTOR, TUBE	0000-67-1981-03	1	7/16 ID X 7/8 OD X 2 3/4	
52			0000-67-1981-40	1	5/8 ID X 1 1/8 OD X 2 1/2	
		EVAPORATOR SCREW KIT	0000-67-1478-36	1		
24		FLATWASHER	0000-67-0402-83	3	1/4	
53		NUT, HEX	0000-67-0411-12	3	6MM	
54		GROMMET, WIRE HARNES	0000-67-1992-98	1	1/2 X 13/16	
55		GROMMET, DRAIN HOSE	0000-67-862A-4A	1	1/2 X 3.8	
56		HOSE, DRAIN	0000-67-1977-05	1	1/2 ID X 4 1/2	
57		CONNECTOR, WIRE	0000-67-1998-83	1		
58		RELAY	0000-67-0957-22	1		
59		HARNES, WIRE	0000-67-1978-37	1		
60		WIRE, JUMPER	0000-67-1977-27	1		
61		SEAL, RING	0000-67-0007-42	1		
62		SEAL, PLATE-TOP	0000-67-0007-41	1		
63		ELBOW, PLASTIC	0000-67-1995-30	1	90 DEG., 1/2 OD	
64		CLAMP, DRAIN HOSE	0000-67-1988-67	1		
65		SCREW, TAPPING	0000-67-1983-78	2	NO. 10 X 3/4 PH	
21		NUT, KEPS	0000-67-1997-59	2	NO. 10 X 32	

6152AB-1 EVAPORATOR PACKAGE ('82 MODEL)

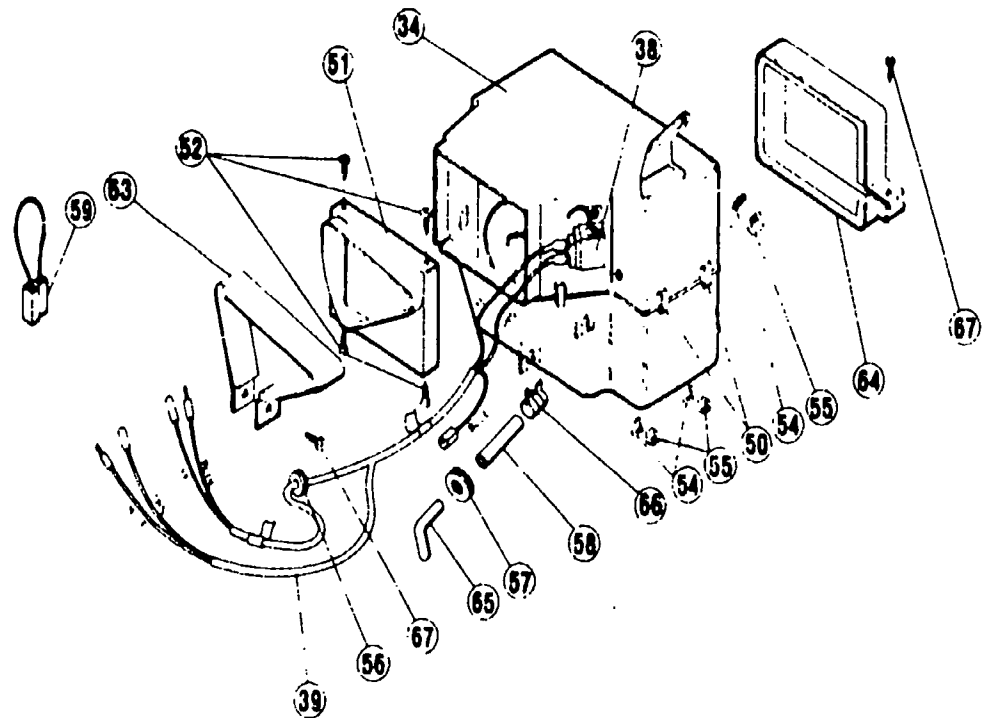
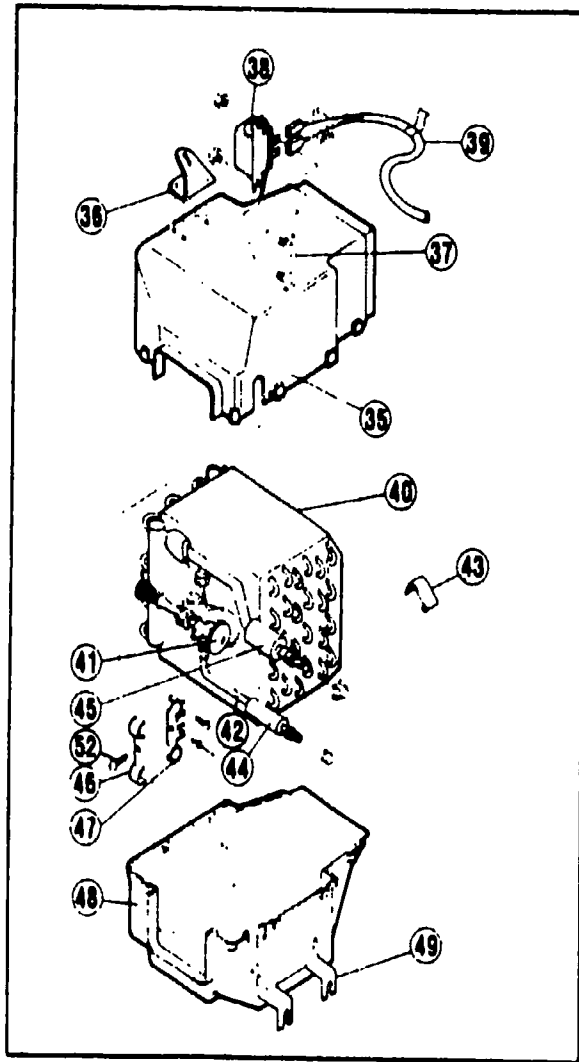

ITEM NO.	D-CODE	DESCRIPTION	PART NO.	QTY	MODEL/DESCRIPTION	REMARKS
34		EVAPORATOR ASSEMBLY	0000-67-2382-94	1		
35		CASE, TOP	0000-67-M00A-3A	1	INJECTION MOULDED	
36		BRACKET, CASE-TOP	0000-67-0008-79	1		
37		BRACKET, THERMOSTAT MOUNTING	0000-67-0007-37	1		
38		SWITCH, THERMOSTAT-PRESET FROSTING	0000-67-0958-17	1		
39		HARNESS, WIRE	0000-67-1998-49	1		
40		COIL, EVAPORATOR	0000-67-B30A-4A	1	FOR EXTENSION EQUALIZER VALVE	
		O-RING	0000-67-0123-21	1	FOR EXTENSION TUBE-EXPANSION VALVE CONNECTION	
41		VALVE, EXPANSION-EXTENSION EQUALIZER	0000-67-0336-81	1		
42		TUBE, ALUMINUM EXTENSION	0000-67-B32A-4A	1		
43		CLAMP NO. 1, BULB	0000-67-B44A-3B	1		
44		PROTECTOR, TUBE	0000-67-1981-03	1	7/16 X 7/8 OD X 2 3/4	
45			0000-67-1981-40	1	5/8 ID X 1 1/8 OD X 2 1/2	
46		CLIP, EVAPORATOR COIL PIPE	0000-67-0010-63	1		
47			0000-67-0010-64	1		
48		CASE, BOTTOM	0000-67-M00A-3A	1	W/ DRAIN PLATE & DRAIN TUBE	
49		BRACKET, CASE-BOTTOM		1		
50		CLIP, RETAINER	0000-67-1977-25	8		
51		CASE, TRANSITION	0000-67-1977-34	1	INJECTION MOULDED	
52		SCREW, TAPPING	0000-67-1982-26	4	NO. 10 X 1/2 PH	
		EVAPORATOR SCREW KIT	0000-67-1478-36	1		
54		FLATWASHER	0000-67-0402-83	3	1/4	
55		NUT, HEX	0000-67-0411-12	3	6MM	
56		GROMMET	0000-67-1992-98	1	1/2 X 13/16	
57			0000-67-B62A-4A	1	1/2 X 3/8	
58		HOSE, DRAIN	0000-67-0977-05	1	1/2 ID X 4 1/2	
59		CONNECTOR, WIRE	0000-67-1998-83	1		
60		RELAY	0000-67-B82A-6P	1		
61		HARNESS, WIRE	0000-67-1978-37	1		
62		WIRE, JUMPER	0000-67-1977-27	1		
63		SEAL, RING	0000-67-0007-42	1		
64		SEAL, TOP PLATE	0000-67-0007-41	1		
65		ELBOW, PLASTIC	0000-67-1995-30	1	90 DEG., 1/2 OD	
66		CLAMP, DRAIN HOSE	0000-67-1988-67	1		
67		SCREW, TAPPING	0000-67-1983-78	2	NO. 10 X 3/4 PH	

6152AC-1 EVAPORATOR PACKAGE ('83 MODEL)

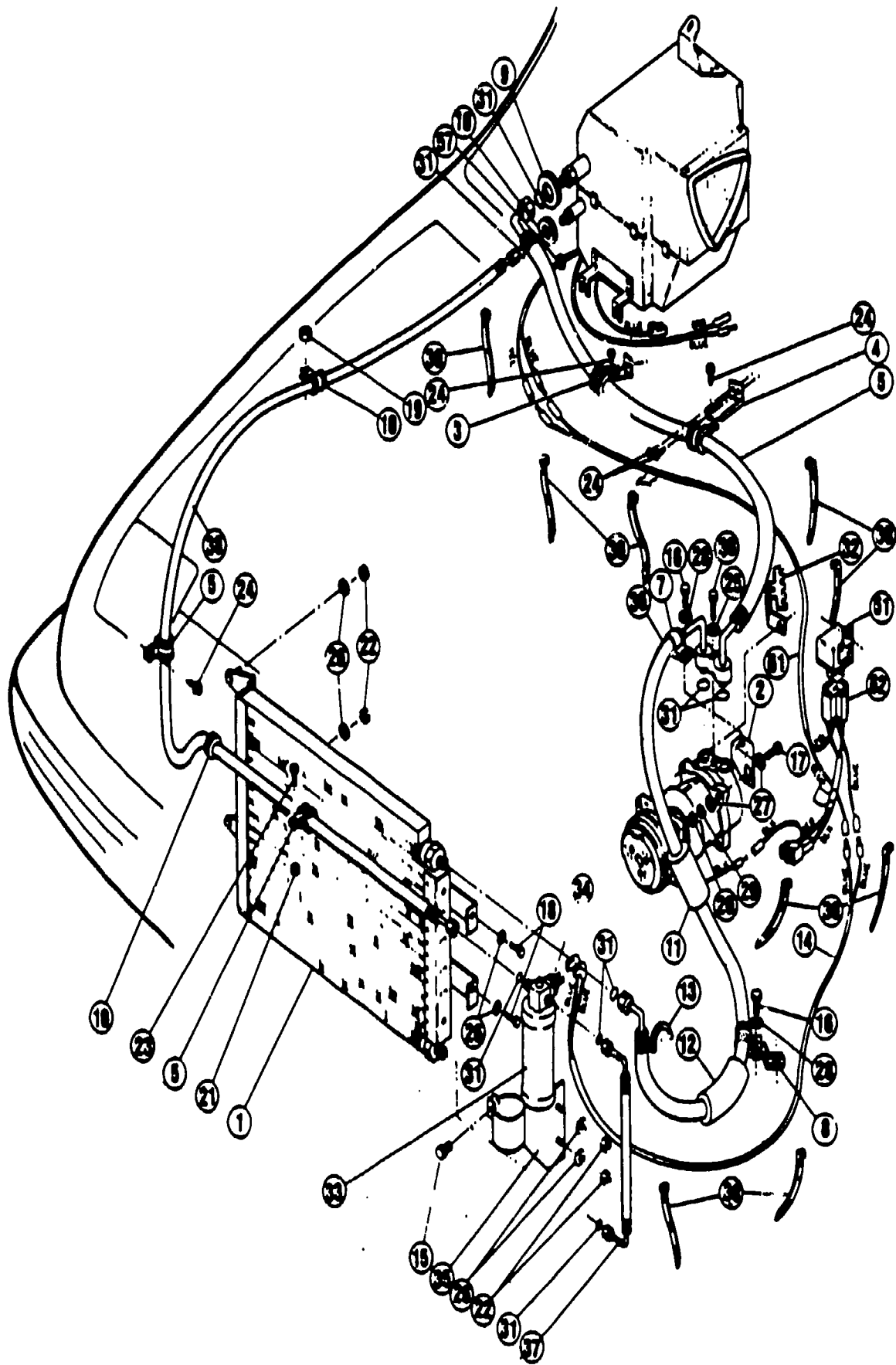

ITEM NO.	D-CODE	DESCRIPTION	PART NO.	QTY	MODEL/DESCRIPTION	REMARKS
41		EVAPORATOR ASSEMBLY	0000-67-2382-94	1		
42		CASE, TOP	0000-67-M00A-3A	1	INJECTION MOULDED	
43		CASE, BOTTOM		1	INJECTION MOULDED	
44		CASE, TRANSITION	0000-67-1977-34	1	INJECTION MOULDED	
45		COIL, EVAPORATOR	0000-67-B30A-4A	1		
46		VALVE, EXPANSION	0000-67-0336-81	1		
47		HARNES, WIRE	0000-67-1998-49	1		
48		SWITCH, THERMOSTAT-PRESET	0000-67-0958-17	1		
49		TUBE, EXTENSION	0000-67-B32A-4A	1		
50		PROTECTOR, TUBE	0000-67-1981-03	1	7/16 ID X 7/8 OD X 2 3/4	
51			0000-67-1981-40	1	5/8 ID X 1 1/8 OD X 2 1/2	
52		O-RING, CAP-TUBE SEAL	0000-67-0123-21	1		
53		O-RING	0000-67-0123-18	1	NO. 8	
54		BRACKET, THERMOSTAT MOUNTING	0000-67-0007-37	1		
55		CLAMP NO. 1, BULB	0000-67-B44A-3B	1		
56		CLIP, EVAPORATOR COIL PIPE	0000-67-0010-63	1		
57			0000-67-0010-64	1		
58		CLIP, RETAINER	0000-67-1977-25	8		
59		SCREW, TAPPING	0000-67-1982-26	2	NO. 10 X 1/2 PH	
60			0000-67-1995-93	4	NO. 8 X 1/2 PH	
		EVAPORATOR SACK KIT	0000-67-1478-36	1		
61		RFLAY	0000-67-B82A-6P	1		
62		HARNES, WIRE	0000-67-1978-37	1		
63		WIRE, CONNECTOR	0000-67-1998-83	1		
64		SEAL, AIR RING	0000-67-0007-42	1		
65		SEAL, TOP PLATE	0000-67-0007-41	1		
66		GROMMET	0000-67-1992-98	1	1/2 X 13/16	
67			0000-67-B62A-4A	1	1/2 X 3/8	
68		HOSE, DRAIN	0000-67-1977-05	1	1/2 ID X 4 1/2	
69		ELBOW, PLASTIC	0000-67-1995-30	1	90 DEG., 1/2 OD	
70		CLAMP, DRAIN HOSE	0000-67-1988-67	1		
71		NUT	0000-67-0411-12	3	6MM	
72		FLATWASHER	0000-67-0402-83	3	1/4	
73		SCREW, TAPPING	0000-67-1983-78	2	NO. 10 X 3/4 PH	

6230A-1 BACK DOOR MECHANISM

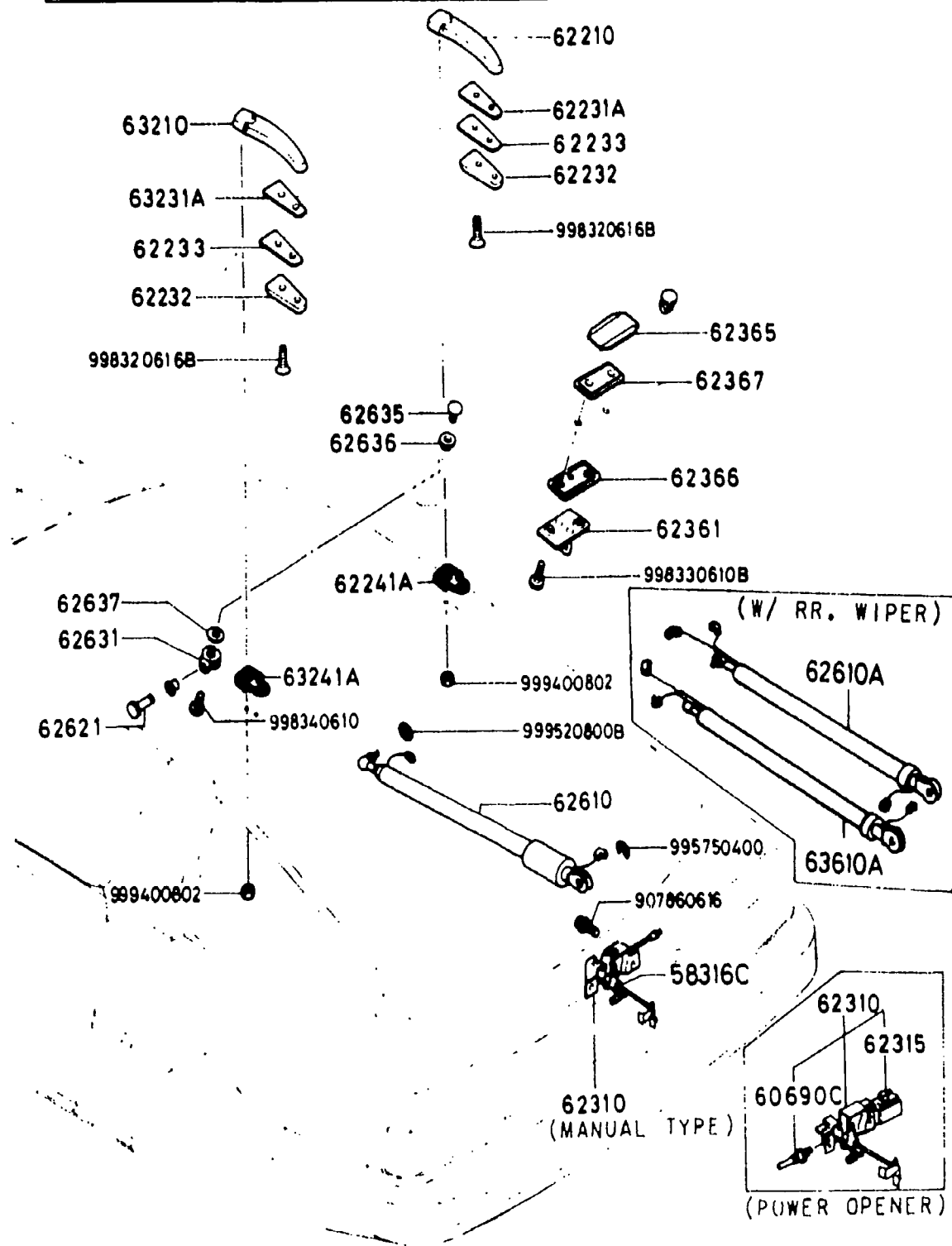
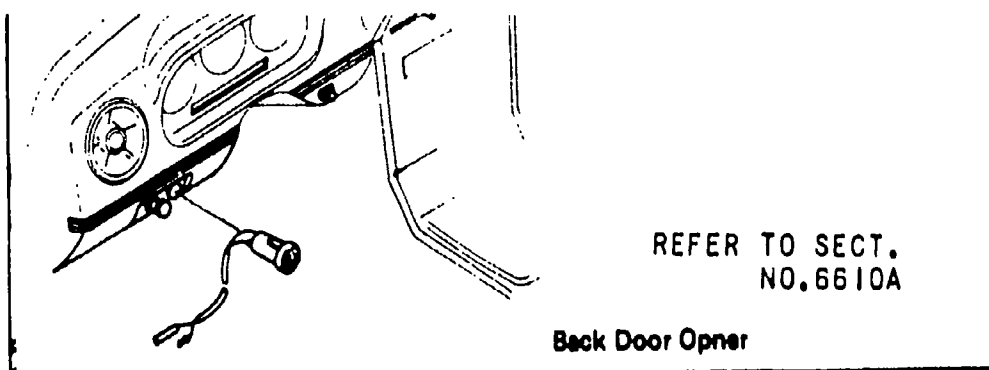

ITEM NO.	D-CODE	DESCRIPTION	PART NO.	QTY	MODEL/DESCRIPTION	REMARKS
	58 316C	CLIP	G030-58-315	2		
	60 690C	SWITCH, ROOM LAMP	0305-60-690	1		
	62 210	HINGE (R)	8871-62-210B	1		
	62 231A	SHIM 'A' (R), HINGE	8871-62-231	1		
	62 232	SHIM 'B', HINGE	8871-62-232A	2		
	62 233	SHIM 'D', HINGE	8871-62-233	2		
	62 241A	SHIM 'C' (R), HINGE	8871-62-241A	1		
	62 310	LOCK, BACK DOOR	FA01-62-310C	1	GS & GSL MODELS	
			FA02-62-310B	1	S MODEL	
	62 315	OPENER, REMOTE CONTROL	8341-62-315	1	GS & GSL MODELS	
	62 361	STRIKER, LOCK	8871-62-361	1		
	62 365	NUT, STRIKER	FA01-62-365	1		
	62 366	SHIM 'A', STRIKER	FA01-62-366	1		
	62 367	SHIM 'B', STRIKER	8871-62-367	1		
	62 610	STAY, DAMPER	8341-89-621	2	S & GS MODELS	
	62 610A	STAY (R), DAMPER	1482-89-621	1	GSL MODEL	
	62 621	PIN, DAMPER	8871-62-621	2		
	62 631	BRACKET, DAMPER	8371-62-631	2		
	62 635	NUT, DAMPER	8871-62-635A	2		
	62 636	SHIM 'A', DAMPER	8871-62-636A	2		
	62 637	SHIM 'B', DAMPER	8871-62-637	2		
	63 210	HINGE (L)	887 210B	1		
	63 231A	SHIM 'A' (L), HINGE	8871-63-231	1		
	63 241A	SHIM 'C' (L), HINGE	8871-63-241A	1		
	63 610A	STAY (L), DAMPER	8341-89-621	1	GSL MODEL	

6300A-1 WINDOW GLASSES

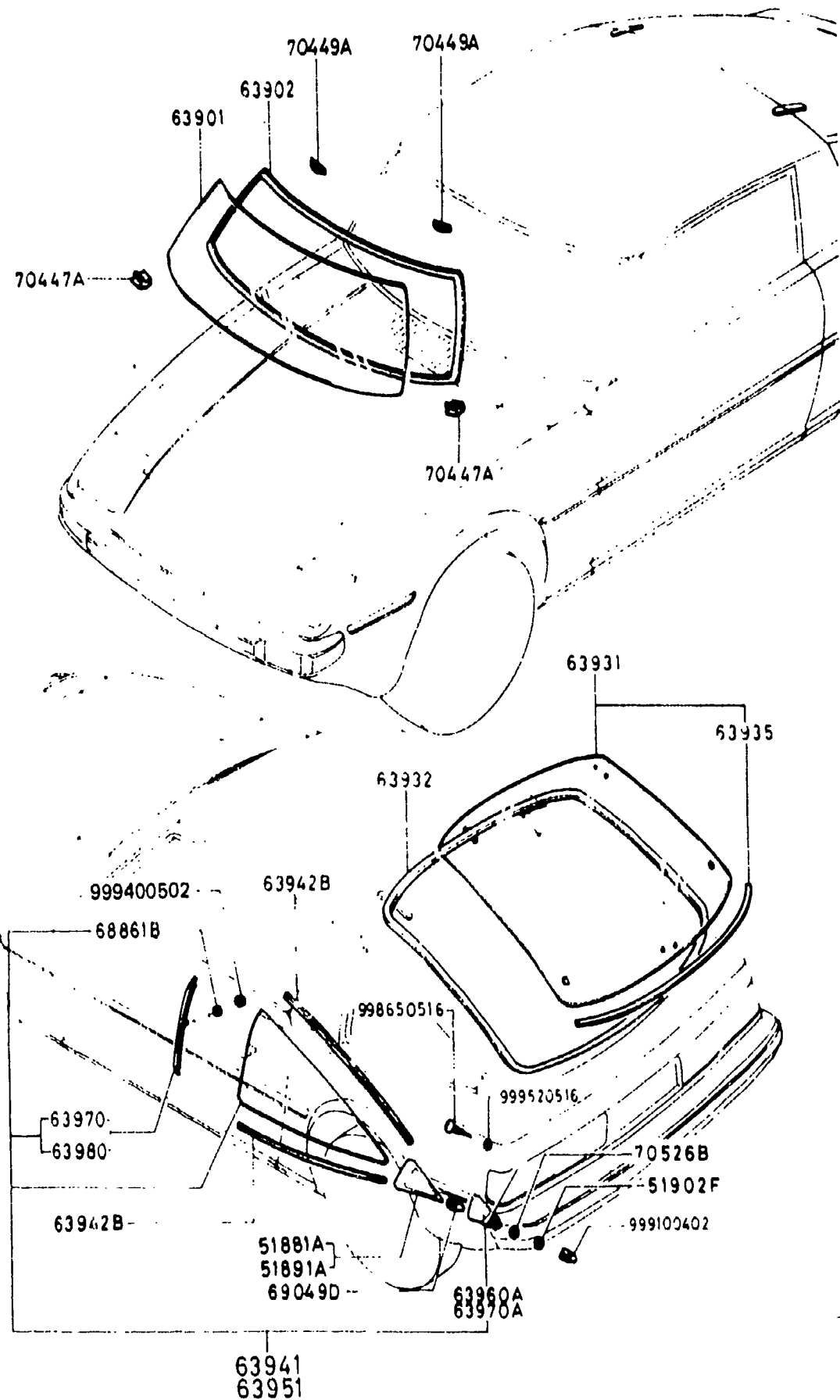

ITEM NO.	D-CODE	DESCRIPTION	PART NO.	QTY	MODEL/DESCRIPTION	REMARKS
51 881A		GARNISH (R), SIDE WINDOW	FA01-51-881A	1		
51 891A		GARNISH (L), SIDE WINDOW	FA01-51-891A	1		
51 902F		PACKING	1029-51-902	2		
63 901		GLASS, WINDSHIELD	FA01-63-901B	1	GS & GSL MODELS	
			FA02-63-901F	1	S MODEL	
63 902		DAM, FRONT W/SHIELD GLASS	1243-63-902	1		
63 931		GLASS, REAR WINDOW	1482-75-890D	1	GSL MODEL	
			8341-75-890D	1	S & GS MODELS	
63 932		WEATHERSTRIP, RR. WINDOW	8871-62-761D	1		
63 935		MOULDING, REAR WINDOW	8871-63-935A	1		
63 941		GLASS (R), SIDE WINDOW	FA01-62-950D	1		
63 942B		DAM, SIDE WINDOW	8871-63-942	4		
63 951		GLASS (L), SIDE WINDOW	FA01-63-950D	1		
63 960A		PLATE (R), GLASS	FA01-62-970	1		
63 970		MOULDING (R), GLASS	8871-62-960A	1		
63 970A		PLATE (L), GLASS	FA01-63-970	1		
63 980		MOULDING (L), GLASS	8871-63-960A	1		
68 861B		SPACER	8871-62-966A	2		
69 049D		NUT, SPEED	0187-69-049A	4		
70 447A		SPACER 'A'	8871-63-911	2		
70 449A		SPACER 'C'	0839-70-449	3		
70 526B		SHEET 'A', SIDE WINDOW	0256-70-526A	2		

6330A-1 SUNROOF (GSL)

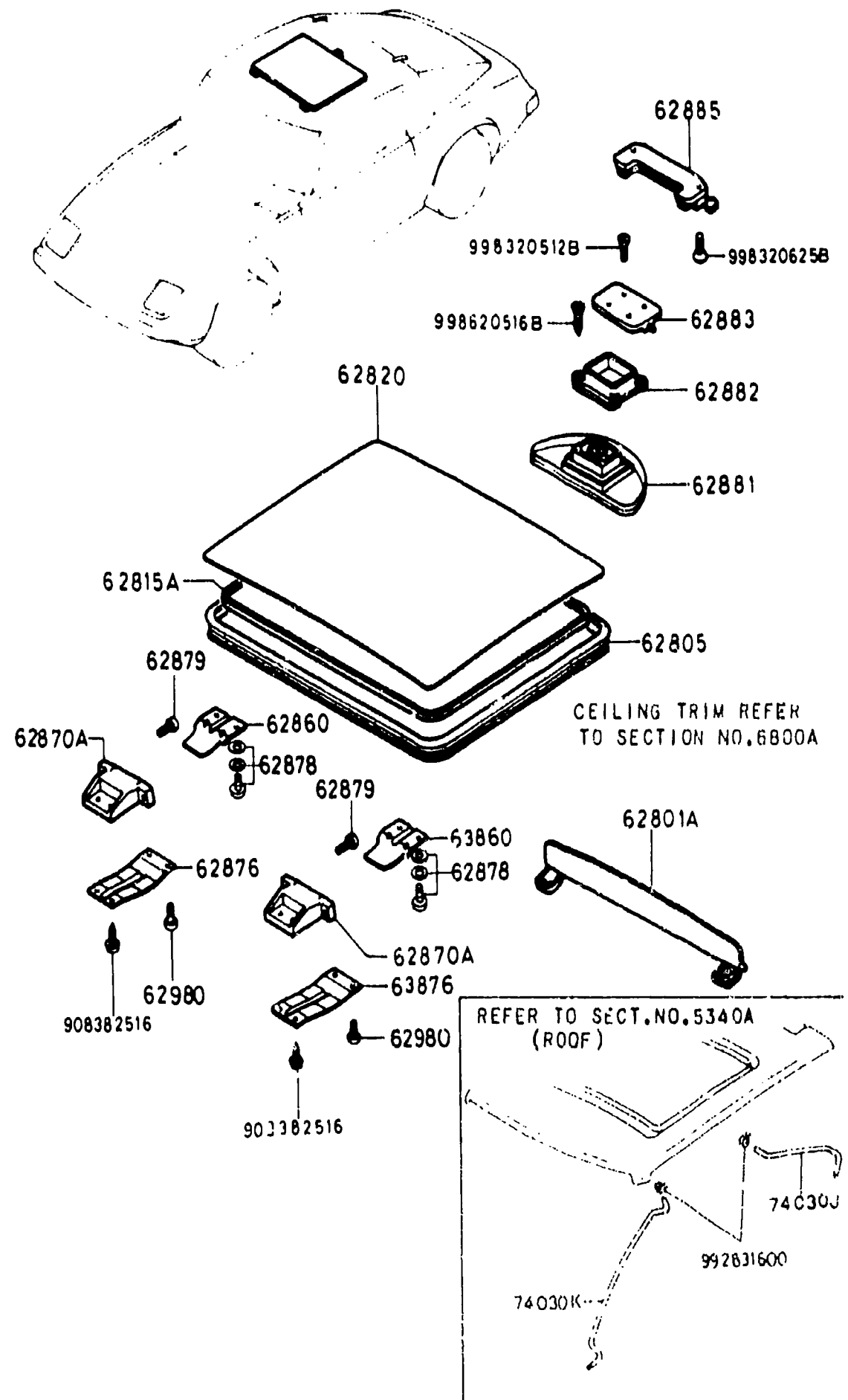

ITEM NO.	D-CODE	DESCRIPTION	PART NO.	QTY	MODEL/DESCRIPTION	REMARKS
62 801A		DEFLECTOR	8346-62-801C	1		
		BLACK	02			
		RED	11			
		TAN	29			FB331 ..600001-
		BROWN	70			
62 805		WEATHERSTRIP, TOP	8970-62-805B	1		
62 815A		PROTECTOR, TOP	8970-62-815B	1		
62 820		SUNROOF	8346-62-820A	1		
62 360		HINGE 'A' (R), TOP	8346-62-875A	1		
62 370A		HINGE 'B', TOP	8346-62-871A	1		
62 876		REINFORCEMENT (R), HINGE	8346-62-876	1		
62 878		SCREW	8346-62-878A	4		
62 879		SCREW	8346-62-879	4		
62 881		LATCH, ROTARY	FA04-62-881A	1		
		BLACK	00			
		RED	11			
		TAN	29			FB331 ..600001-
		BROWN	70			
62 882		COVER LATCH	8346-62-882	1		
62 883		PLATE LOCK	8346-62-883	1		
62 885		HOOK SLIDE	8346-62-885	1		
62 980		SCREW	8346-62-980	4		
63 860		HINGE 'A' (L), TOP	8346-63-875A	1		
63 876		REINFORCEMENT (L), HINGE	8346-63-876	1		
74 030J		PIPE, VINYL	8973-56-066	2		
74 030K		HOSE, DRAIN	8973-56-065B	2		

6600A-1 SWITCH & RELAY (ENGINE & TRANSMISSION)

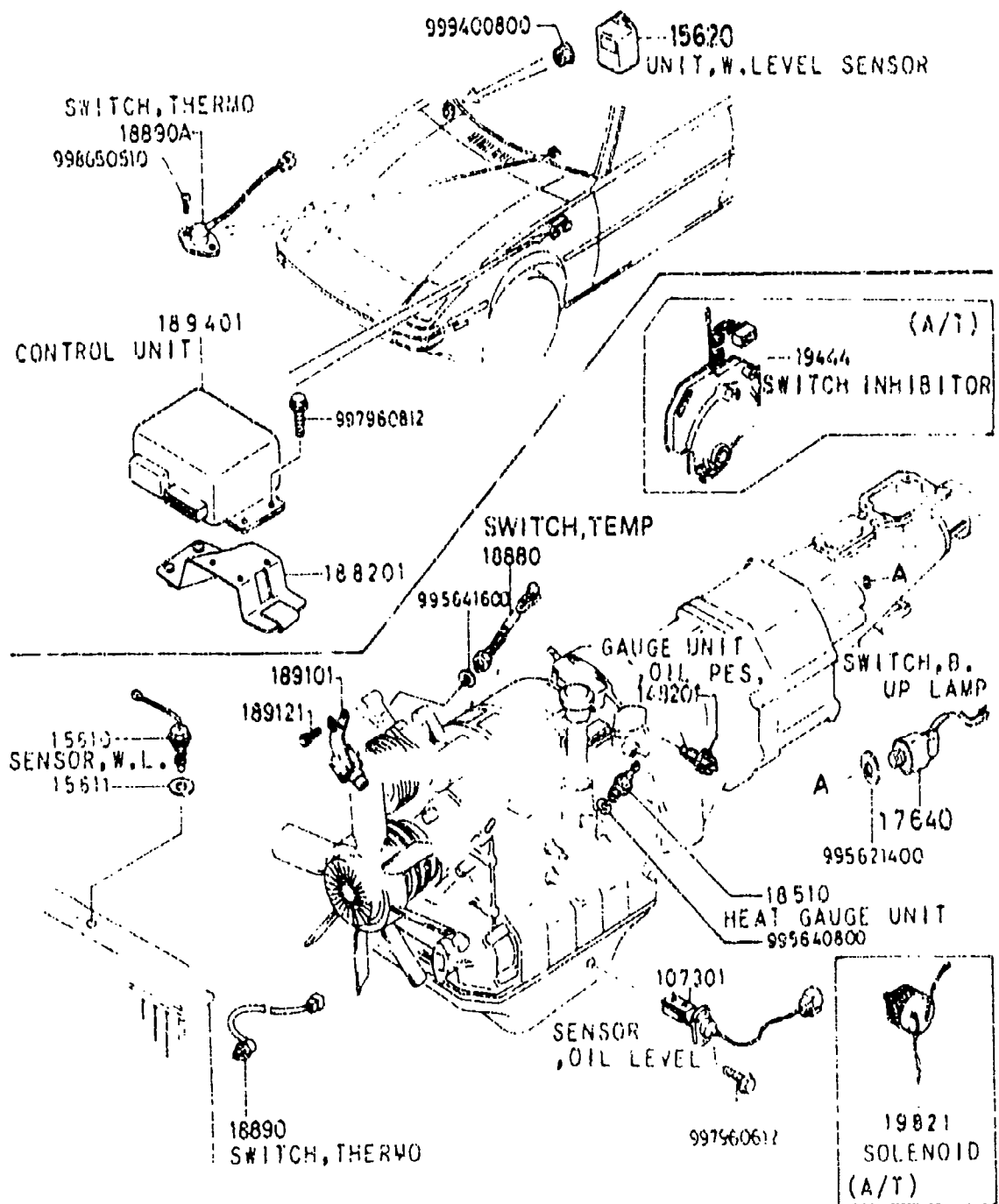

ITEM NO.	D-CODE	DESCRIPTION	PART NO.	QTY	MODEL/DESCRIPTION	REMARKS
	10 7301	SENSOR, OIL LEVEL	N201-10-730	1		
	14 8201	GAUGE UNIT, OIL PRESSURE	N201-14-820	1		
	15 610	SENSOR, WATER LEVEL	8553-15-610B	1		
	15 611	GASKET	8553-15-611	1		
	15 620	UNIT, WATER LEVEL SENSOR	8248-15-620	1		
	17 640	SWITCH, BACK-UP LAMP	1391-17-640	1	M T	
	18 510	UNIT, HEAT GAUGE	8569-18-510A	1		
	18 8201	BRACKET, CONTROL UNIT	3871-18-820C	1		
	18 880	SWITCH, TEMPERATURE	8341-18-880	1		
	18 890	SWITCH, THERMO	6182-18-970A	1		
	18 890A	SWITCH, THERMO	N201-18-890	1	'81 & '82 MODELS	
			N233-18-890	1	'83 MODEL	
	18 9101	SENSOR THROTTLE	1480-18-910B	1		
	18 9121	BOLT	1480-18-912B	2		
	18 9401	CONTROL UNIT	N201-18-940	1	'81 & '82 MODELS M-T CAL.	
			N202-18-940	1	'81 & '82 MODELS	
			N203-18-940	1	'81 & '82 MODELS M T FED.	
			N231-18-940	1	'83 MODEL M T	
			N232-18-940	1	'83 MODEL A T	
	19 444	SWITCH, INHIBITOR	6872-19-444B	1	A T	
	19 821	SOLENOID, DOWNSHIFT	1675-19-821	1	A T	

SWITCHES AND RELAYS HAVE BEEN SHOWN IN THE FOLLOWING FOUR (4) SECTIONS.

SECTION NO.	SECTION NAME
6600A	SWITCH & RELAY (ENGINE & TRANSMISSION)
6610A	SWITCH (DASHBOARD)
6620A	SWITCH (INTERIOR)
6630A	SWITCH (RELAY & HORN)

SECTION INDEX -- BODY

STARTING LOCATION	SECT. NO.	SECTION NAME	STARTING LOCATION	SECT. NO.	SECTION NAME	STARTING LOCATION	SECT. NO.	SECTION NAME
2 - C 3	0900A	KEY SETS	2 - E 8	6142A	COMPRESSOR MOUNTING KIT, COMPRESSOR/CLUTCH ASSEMBLY & REPAIR PARTS ('81 MODEL)	2 - H 11	6970A	SERVICE TOOLS
2 - D 3	5000A	FRONT BUMPER	2 - F 8	6142AB	COMPRESSOR MOUNTING KIT, COMPRESSOR/CLUTCH ASSEMBLY & REPAIR PARTS ('82 MODEL)	2 - I 11	6900A	VISOR, ASSIST HANDLE & MIRRORS
2 - E 3	5005A	RADIATOR GRILLE	2 - G 8	6142AC	COMPRESSOR MOUNTING KIT, COMPRESSOR/CLUTCH ASSEMBLY & REPAIR PARTS ('83 MODEL)	2 - L 11	6930A	CAUTION PLATES
2 - F 3	5010A	REAR BUMPER	2 - H 8	6152A	EVAPORATOR PACKAGE ('81 MODEL)			
2 - G 3	5030A	WINDOW MOULDINGS	2 - I 8	6152AB	EVAPORATOR PACKAGE ('82 MODEL)			
2 - H 3	5040A	BODY MOULDINGS	2 - J 8	6152AC	EVAPORATOR PACKAGE ('83 MODEL)			
2 - I 3	5060A	SIDE PROTECTORS	2 - K 8	6230A	BACK DOOR MECHANISM			
2 - J 3	5100A	HEAD LAMPS	2 - L 8	6300A	WINDOW GLASSES			
2 - K 3	5103A	HEAD LAMP RETRACTORS	2 - M 8	6330A	SUNROOF (GSI)			
2 - L 3	5105A	FRONT COMBINATION & SIDE TURN LAMPS	2 - N 8	6600A	SWITCH & RELAY (ENGINE & TRANSMISSION)			
2 - M 3	5110A	REAR COMBINATION LAMPS						
2 - N 3	5120A	LICENSE & REAR SIDE TURN LAMPS	2 - C 9	6610A	DASHBOARD SWITCHES (MANUAL OPERATING)			
2 - C 4	5125A	INTERIOR LAMPS (GS & GSI)	2 - D 9	6611A	COMBINATION SWITCH			
2 - D 4	5170A	ORNAMENTS	2 - E 9	6615A	POWER WINDOW SWITCH			
2 - E 4	5180A	COWL & EXTRACTOR GRILLES	2 - F 9	6620A	DOOR, PARKING LAMP & KICK DOWN SWITCH			
2 - F 4	5230A	HOOD	2 - G 9	6630A	RELAY (BODY)			
2 - G 4	5310A	BODY PANELS (FRONT)	2 - H 9	6635A	HORN			
2 - I 4	5340A	BODY PANELS (SIDE & ROOF)	2 - I 9	6640A	AUTO CRUISE CONTROL			
2 - J 4	5360A	BODY PANELS (FLOOR)	2 - J 9	6680A	AUDIO SYSTEM			
2 - K 4	5370A	FLOOR ATTACHMENTS	2 - M 9	6700A	WIRE HARNESS (FRONT & REAR)			
2 - L 4	5500A	DASHBOARD EQUIPMENT	2 - N 9	6701A	WIRE HARNESS (ENGINE & TRANSMISSION)			
2 - N 4	5540A	METERS						
2 - C 5	5560A	DASHBOARD & RELATED	2 - C 10	6702A	WIRE HARNESS (DASHBOARD)			
2 - E 5	5570A	CONSOLE	2 - D 10	6703A	WIRE HARNESS (DOOR, FLOOR & CEILING)			
2 - G 5	5580A	VENTILATOR	2 - E 10	6704A	WIRE HARNESS CLAMPS			
2 - H 5	5700A	SEATS ('81 & '82) MODELS	2 - F 10	6720A	WINDSHIELD WASHER			
2 - C 6	5700AA	SEATS ('83 MODEL)	2 - G 10	6730A	WINDSHIELD WIPER			
2 - H 6	5790A	SEAT BELTS	2 - H 10	6740A	WIPER MOTOR (COMPONENTS ONLY)			
2 - J 6	5800A	FRONT DOOR	2 - I 10	6750A	REAR WINDOW WIPER & WASHER			
2 - K 6	5830A	FRONT DOOR MECHANISM	2 - J 10	6760A	REAR WINDOW WIPER MOTOR (COMPONENTS ONLY)			
2 - C 7	5840A	FRONT DOOR TRIM & RELATED PARTS	2 - K 10	6800A	CEILING TRIM			
2 - F 7	6100A	HEATER	2 - C 11	6840A	TRIM & SCUFF PLATE			
2 - G 7	6110A	HEATER UNIT	2 - F 11	6860A	FLOOR MATS & PADS			
2 - H 7	6115A	HEATER CONTROLS						
2 - I 7	6120A	HEATER BLOWER						
2 - L 7	6132A	CONDENSER PACKAGE ('81 MODEL)						
2 - L 7	6132AB	CONDENSER PACKAGE ('82 MODEL)						
2 - C 8	6132AC	CONDENSER PACKAGE ('83 MODEL)						

**6610A-1 DASHBOARD SWITCHES
(MANUAL OPERATING)**

ITEM NO.	D-CODE	DESCRIPTION	PART NO.	QTY	MODEL/DESCRIPTION	REMARKS
	60 715	SHIELD, HEAT	8871-66-242	1		
	60 721	PROTECTOR	FA01-66-241	1		
	66 250	LIGHTER, CIGAR	FA01-66-250	1		
	66 251	RING, ILLUMINATION	8182-66-251	1		
	66 251A	CORD, SHORT	FA01-66-251	1		
	66 254	BULB, CIGAR LIGHTER	0000-11-0293	1	(A12V 3.4W)	
	66 340	SWITCH, MAIN	FA03-66-340	1	(USE W/ A.C.C.) GSL MODEL	
	66 422	VALVE, MAIN SWITCH	B001-66-422	1		
	66 460	SWITCH, REAR DEFROSTER	B001-66-460	1		
	66 630B	SWITCH, REMOTE CONTROL	FA01-66-630	1		
	66 670	SWITCH, RETRACTOR	FA01-66-670	1		
	66 700	SWITCH, FUEL LID OPENER	FA01-66-700	1		
	66 800	SWITCH, MOTOR ANTENNA	FA07-66-890	1	'81 & '82 MODELS	
	67 540A	SWITCH, WIPER	FA02-67-540	1		

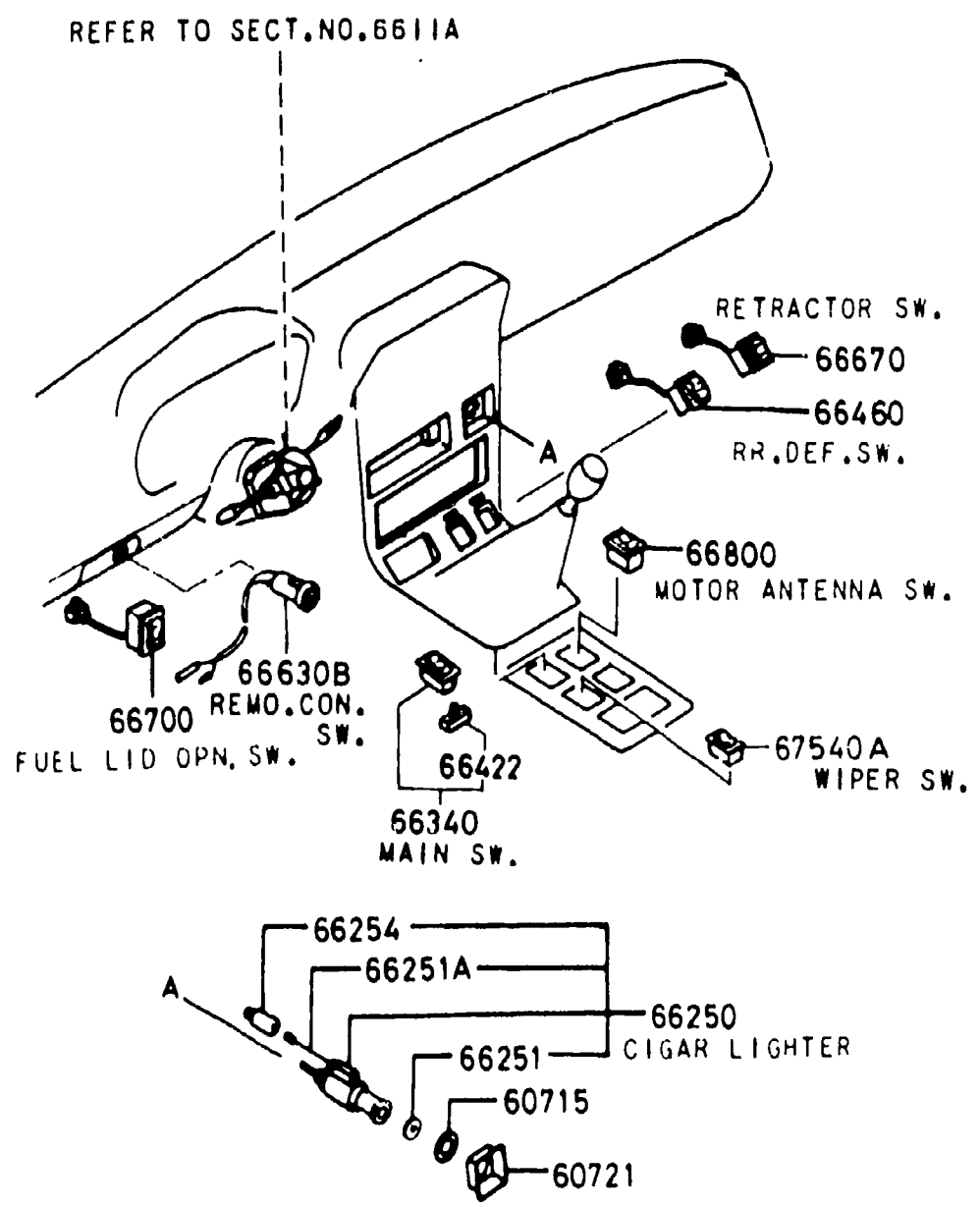

6611A-1 COMBINATION SWITCH

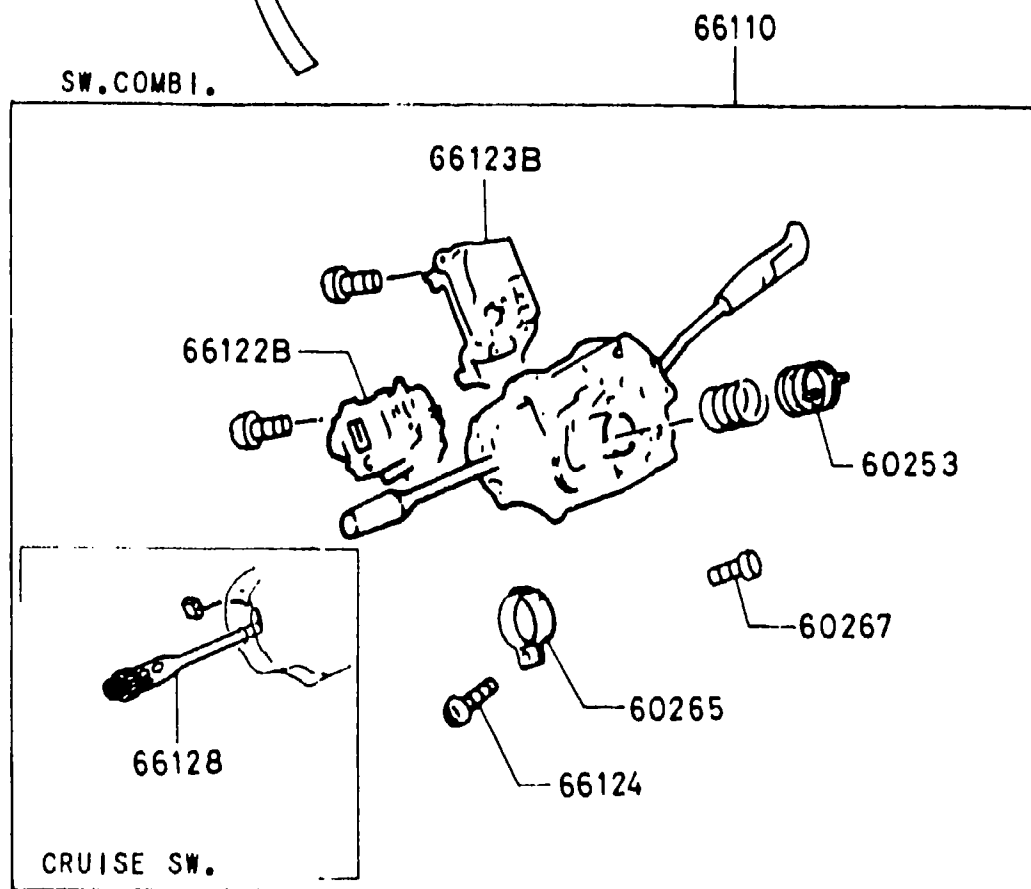
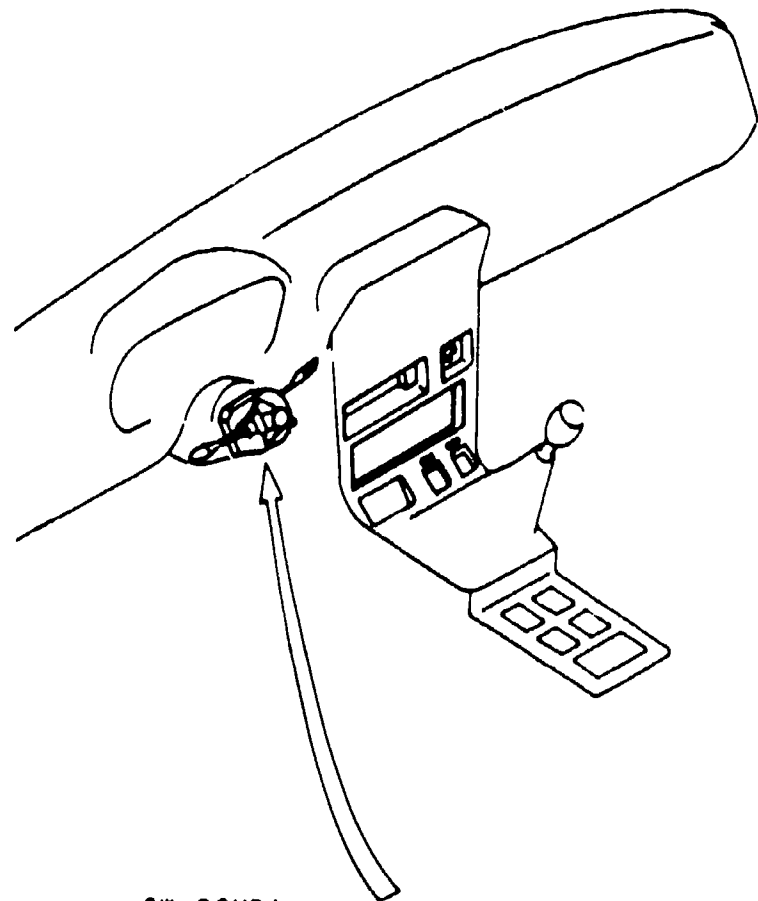

ITEM NO.	D-CODE	DESCRIPTION	PART NO.	QTY	MODEL/DESCRIPTION	REMARKS
	60 253	CAM, CANCEL	BA29-66-126	1		
	60 265	HOLDER, BAND	BA29-66-129	1		
	60 267	CONTACT, HORN	8182-66-127	1		
	66 110	SWITCH, COMBINATION	FA01-66-120	1	(W/O A.C.C.) S & GS MODELS	
			FA02-66-120	1	(USE W/ A.C.C.) GSL MODEL	
	66 122B	SWITCH, LIGHT & TURN	FA01-66-122	1		
	66 123B	SWITCH, WIPER	BA30-66-123	1		
	66 124	BOLT, BAND HOLDER	8182-66-124	1		
	66 128	SWITCH, A.C.C.	FA02-66-128	1		

6615A-1 POWER WINDOW SWITCH

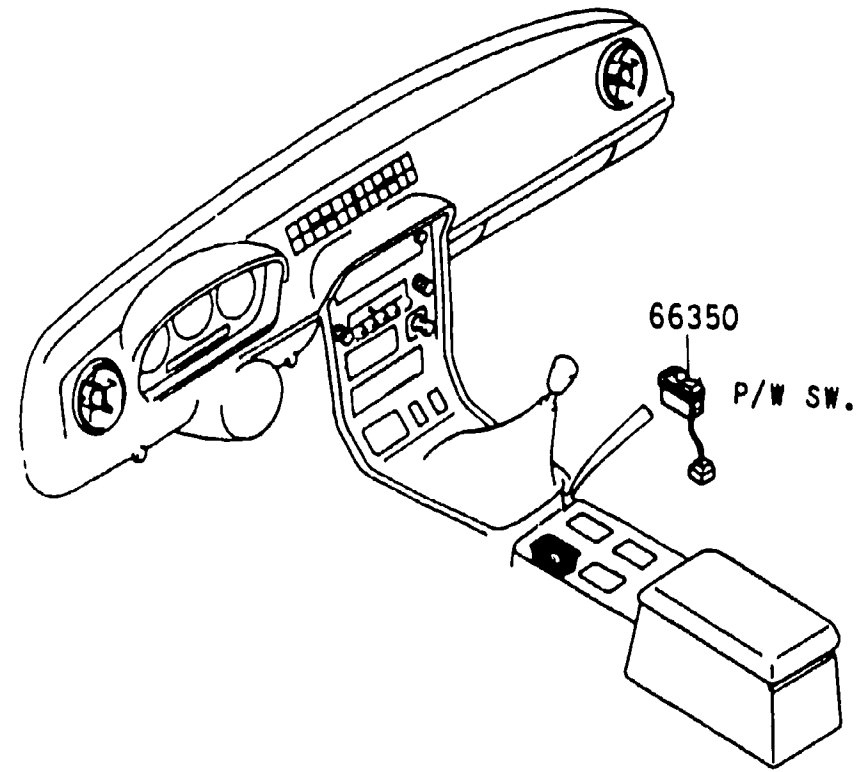

ITEM NO.	D-CODE	DESCRIPTION	PART NO.	QTY	MODEL/DESCRIPTION	REMARKS
	66 350	SWITCH, POWER WINDOW	FA03-66-350A	1	'81 MODEL	
				2	'82 & '83 MODELS	

6620A-1 DOOR, PARKING LAMP & KICK DOWN SWITCH

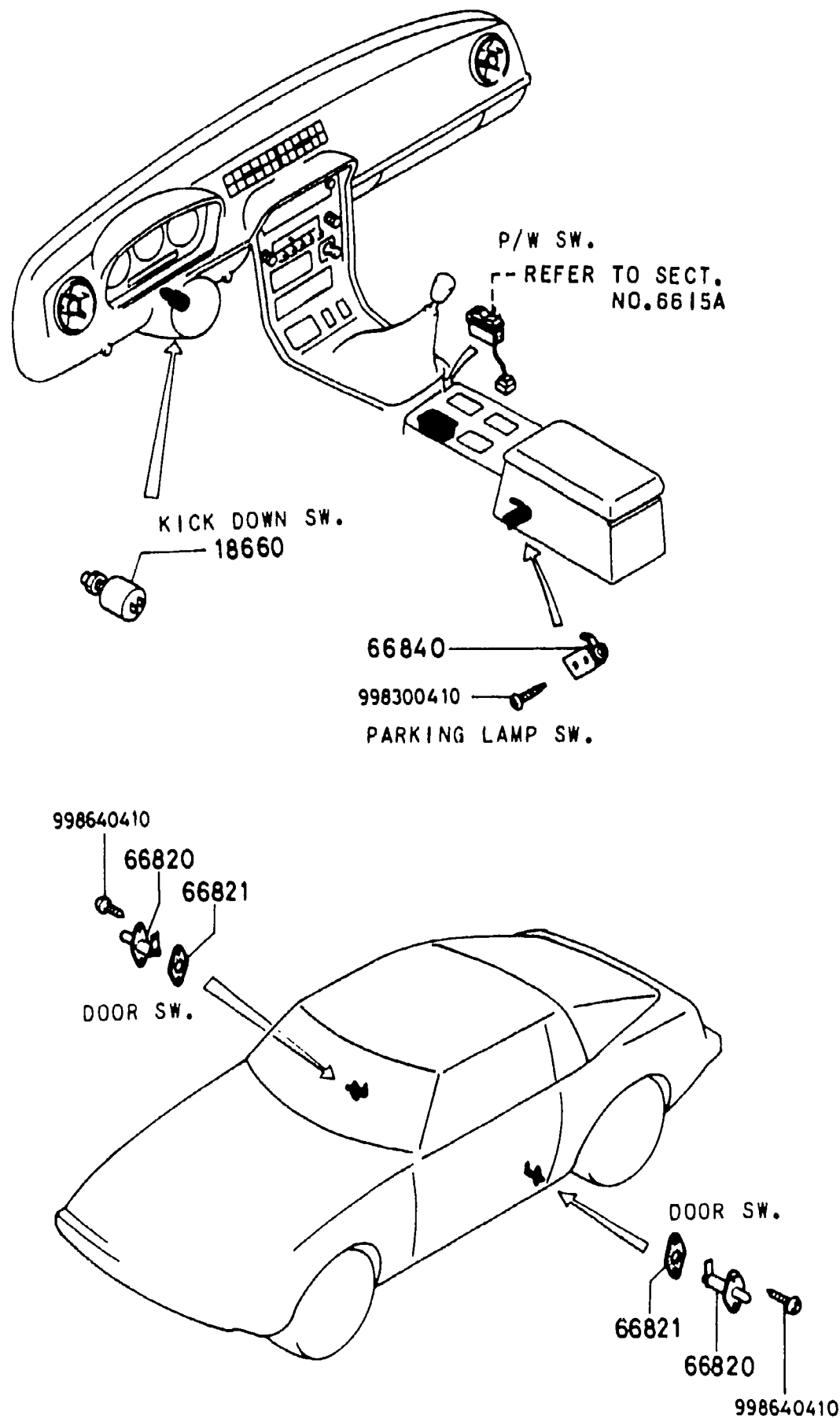

ITEM NO.	D-CODE	DESCRIPTION	PART NO.	QTY	MODEL/DESCRIPTION	REMARKS
	18 660	SWITCH, KICK DOWN	2691-18-660	1	A/T	
	66 820	SWITCH, DOOR	8001-66-540	2		
	66 821	WASHER, ADJUST	0209-66-821	2		
	66 840	SWITCH, PARKING LAMP	8871-66-450	1		

6630A-1 RELAY (BODY)

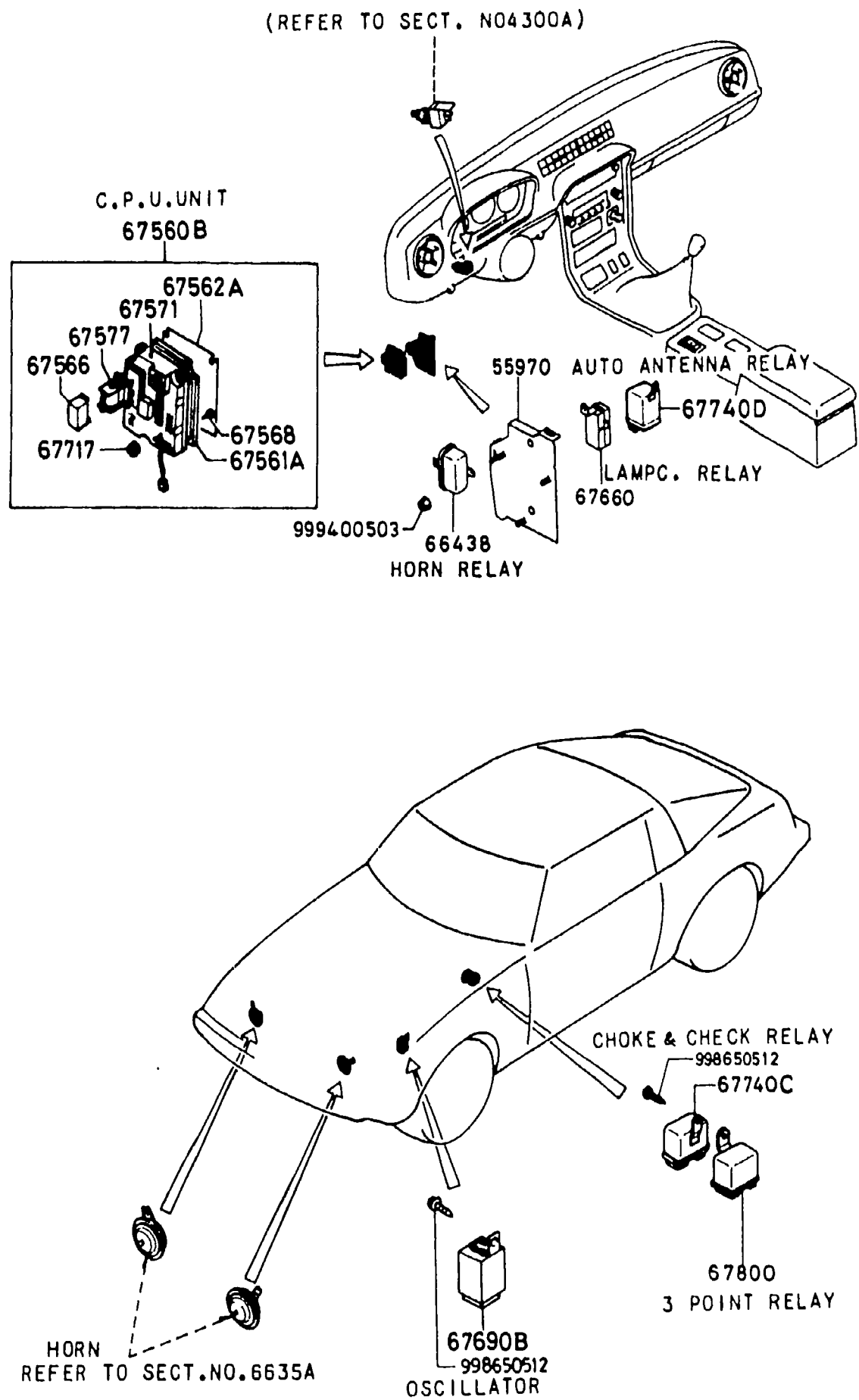

ITEM NO.	D-CODE	DESCRIPTION	PART NO.	QTY	MODEL/DESCRIPTION	REMARKS
	55 970	BRACKET	FA03-66-820B	1		
	66 438	RELAY, HORN	1524-66-810B	1	(USE W/O ILLUM. KEY & WARNING LAMP) '81 & '82 MODELS	FB331 ..500001-634422
			FA01-66-810A	1	'82 & '83 MODELS	FB331 ..634423-
	67 560B	UNIT, CENTRAL PROCESSING	FA03-67-560	1	(USE W/O ILLUM. KEY & WARNING LAMP)	
			FA02-67-560	1	(USE W/ ILLUM. KEY & WARNING LAMP)	
	67 561A	CIRCUIT	FA02-67-573	1		
	67 562A	PLATE	FA02-67-574	1		
	67 566	COVER, CONTROL UNIT	FA02-67-572	1		
	67 568	SCREW, TAPPING	8545-67-568	10		
	67 571	CASE, CONTROL UNIT	FA02-67-571	1		
	67 577	RELAY, FLASHER	FA02-67-577	1	'81 MODEL	FB331 ..500001-503735
				1		FB331 ..503736-
	67 660	RELAY, LAMP CHECKER	BE32-67-680A	1	(USE W/O ILLUM. KEY & WARNING LAMP)	
	67 690B	OSCILLATOR	FA30-67-690	1	'82 & '83 MODEL	
			< AN > FA30-67-690A	1		
	67 717	BUSHING	0866-67-717	3		
	67 740C	RELAY, CHOKE & CHECK	8173-67-740A	1		
	67 740D	RELAY, AUTO ANTENNA	FA01-67-740	1		
	67 800	RELAY, 3-POINT	1480-67-740	1	'81 & '82 MODELS	
				2	M/T '83 MODEL A/T	

6635A-1 HORN

ITEM NO.	D-CODE	DESCRIPTION	PART NO.	QTY	MODEL/DESCRIPTION	REMARKS
	66 771A	GROMMET, SCREW	8572-66-771	2	'81 MODEL	
	66 780A	HORN, HIGH TONE	3874-66-780	1		
	66 790	HORN, LOW TONE	3874-66-790	1		

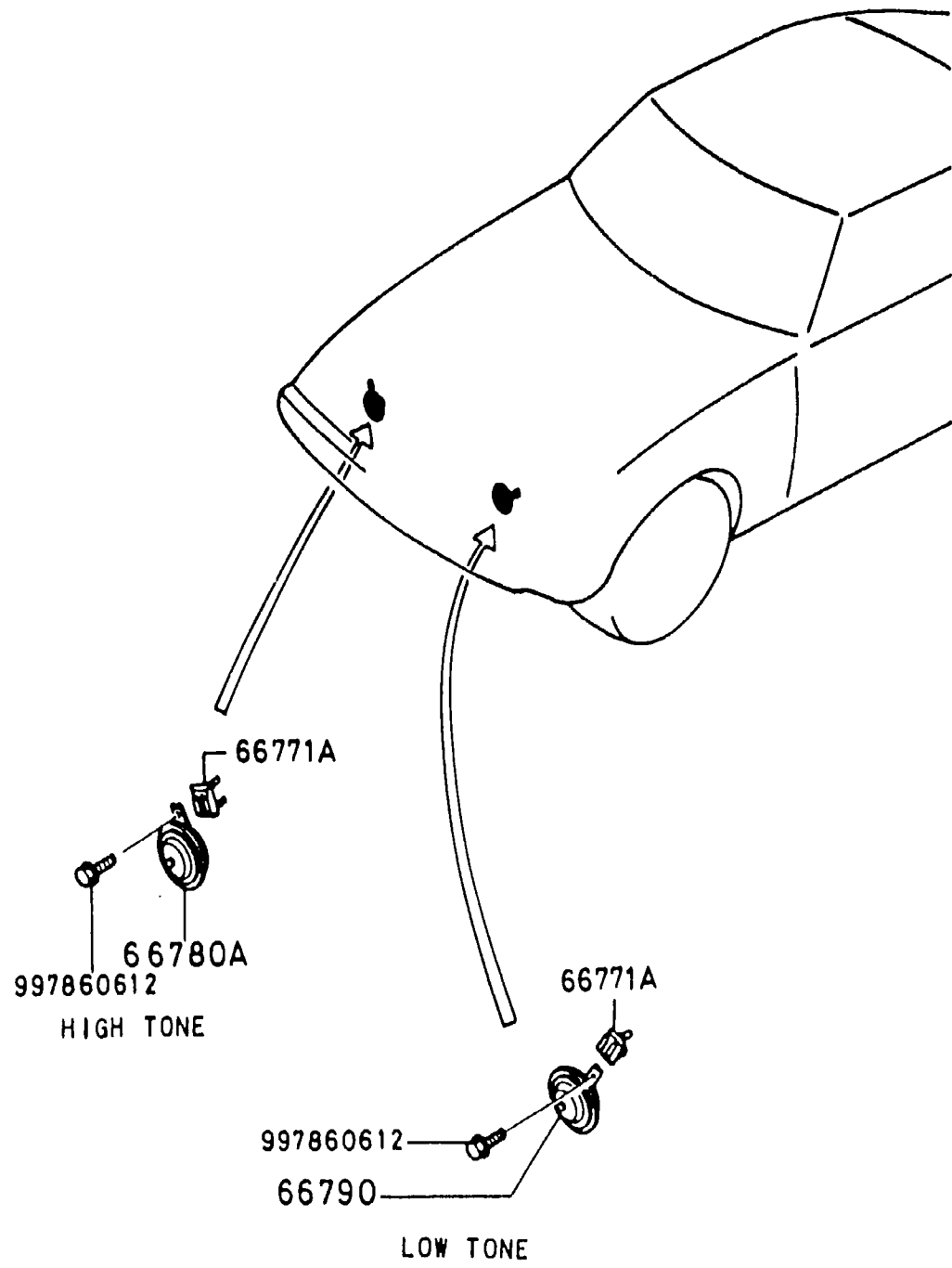

6640A-1 AUTO CRUISE CONTROL

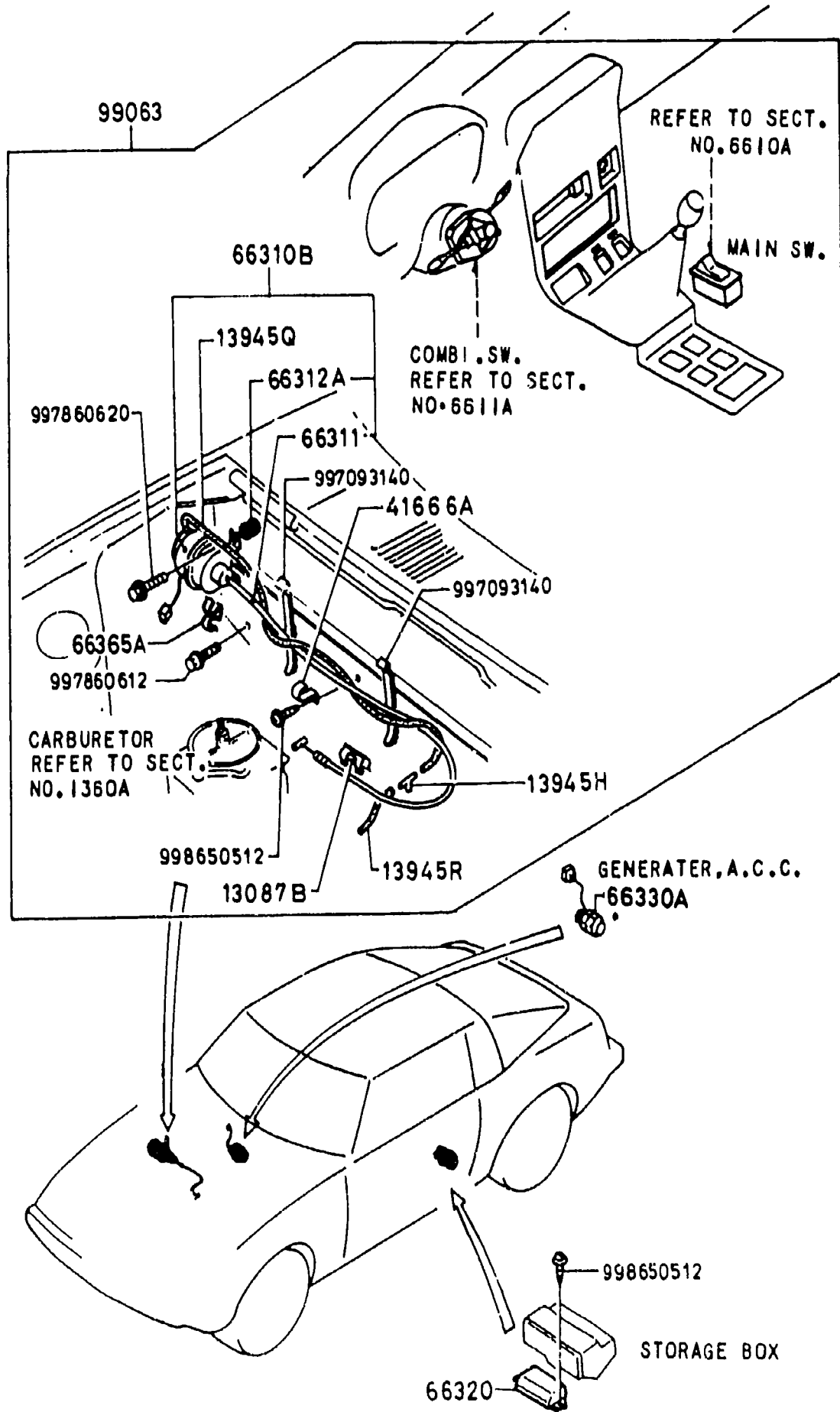

ITEM NO.	D-CODE	DESCRIPTION	PART NO.	QTY	MODEL/DESCRIPTION	REMARKS
	13 087B	SPRING	8871-13-087A	1		
	13 945H	CONNECTOR	1700-13-945A	1	'81 & '82 MODELS	
	13 945Q	PIPE	FA02-66-361	1	'81 & '82 MODELS	
			FA43-66-361A	1	'83 MODEL	
	13 945R	PIPE	9935-10-4095	1	'81 MODEL	FB331 ..500001-524457
				1	'81 & '82 MODELS	FB331 ..524458-
	41 666A	CLIP	FA43-66-315	1	'83 MODEL	
	66 310B	ACTUATOR, A.C.C.	FA43-66-310B	1		
	66 311	WIRE, A.C.C.	FA03-66-311	1	'81 & '82 MODELS	
			FA43-66-311	1	'83 MODEL	
	66 312A	PROTECTOR	FA03-66-312	2		
	66 320	BOX, A.C.C.	FA02-66-320B	1	'81 MODEL	
			FA30-66-320B	1	'82 & '83 MODELS	
	66 330A	GENERATOR, A.C.C.	GA03-66-330A	1	(USE W/ A.C.C.) '81 MODEL	
	66 365A	CLIP	FA43-66-365	2	'83 MODEL	
	99 063	AUTO CRUISE CONTROL SET	FA30-99-063A	1	'83 MODEL	

6680A-1 AUDIO SYSTEM

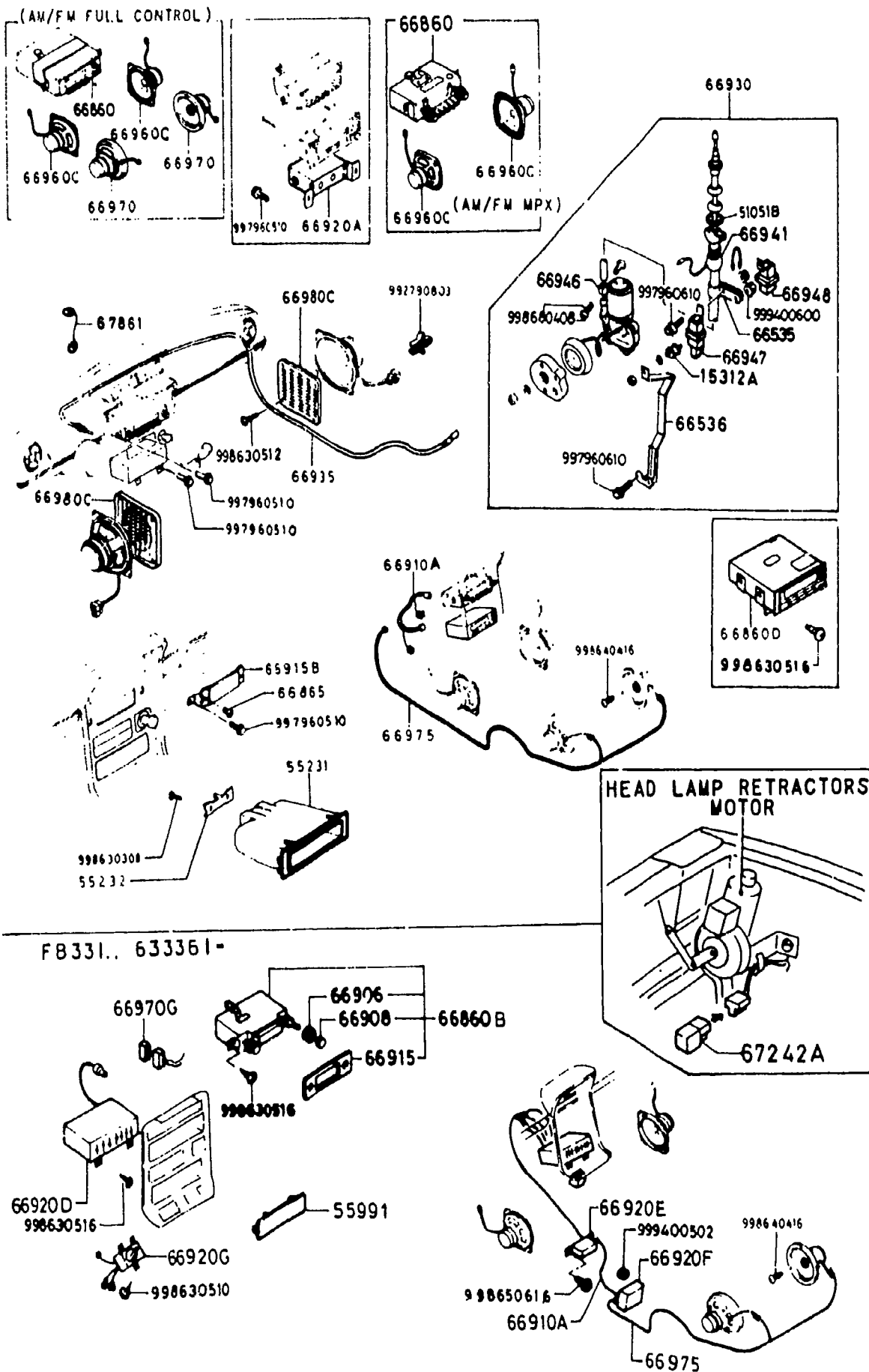

ITEM NO.	D-CODE	DESCRIPTION	PART NO.	QTY	MODEL/DESCRIPTION	REMARKS
	15 312A	RUBBER, INSULATION	1757-15-312	1		
	51 051B	PROTECTOR	8572-51-051	1		
	55 231	ORNAMENT, STEREO	1363-55-231C	1	(W/O CASSETTE) '81 MODEL	
		BLACK	00			
	55 232	TERMINAL, PLATE	8118-55-232	1	(W/O CASSETTE) '81 MODEL	
	55 991	ORNAMENT, TUNER	FA48-55-231	1	'83 MODEL	
	66 535	BRACKET, ANTENNA NO. 1	FA02-66-941	1		
	66 536	BRACKET, ANTENNA NO. 2	FA02-66-942	1	'81 - '82 MODEL	FB331 ..50001-717535
			FA43-66-942	1	'83 MODEL	FB331 ..717536-
	66 860	RADIO, AUTO	0000-81-456C	1	AM/FM MPX (CLARION) '81 MODEL, S & GS '82 MODEL S	
			0000-81-481C	1	AM/FM FULL CONTROL (CLARION) '81 MODEL, GSL '82 MODEL, GS & GSL	
			0000-81-3001	1	AM/FM FULL CONTROL (CLARION) '83 MODEL, S	
	66 860B	PLAYER, TAPE-CASSETTE	0000-81-0790	1	5-BUTTON COMBO (CLARION) '83 MODEL, GS	
			0000-81-0975-83	1	ETR COMBO (CLARION) '82 & '83 MODELS, GSL	
	66 860D	DECK, TAPE-CASSETTE	0000-81-880C	1	DECK ONLY (CLARION) '81 & '82 MODELS, GSL '83 MODEL, S	
			0000-81-0211-83	1	DECK ONLY (FUJITSU) '81 MODEL, S & GS	
	66 865	SCREW	0222-66-865A	2	'81 & '82 MODELS	
		BLACK	00			
	66 906	KNOB, PLAYER	0000-81-0790	2	FOR 5-BUTTON COMBO (CLARION)	
			0000-81-9700-83	2	FOR ETR COMBO (CLARION)	
			0000-81-0211-KB	2	FOR TAPE DECK (FUJITSU)	
	66 908	KNOB, PLAYER	0000-81-0423	2	FOR AM/FM MPX & AM/ FM FULL CONTROL	
	66 910A	CORD, DIN	FA05-66-910A	1	'81 & '82 MODELS	
			FA09-66-910A	1	'82 MODEL	FB331 ..633361-
			FA45-66-910	1	'83 MODEL	
	66 915	PLATE, FACE	0000-81-9710-83	1	FITS ETR COMBO (CLARION), 0000-81-0975-83	

6680A-2 AUDIO SYSTEM

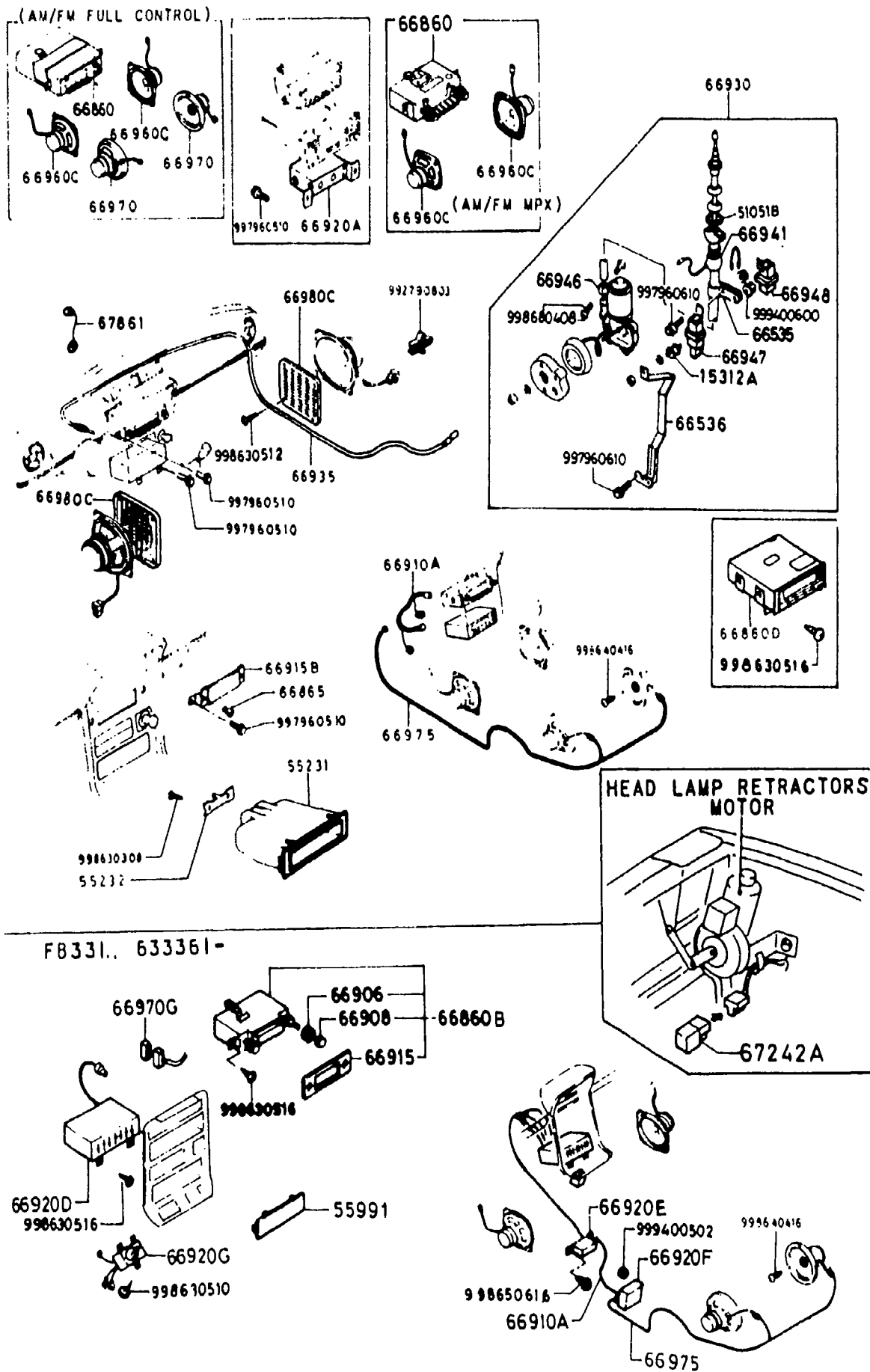

ITEM NO.	D-CODE	DESCRIPTION	PART NO.	QTY	MODEL/DESCRIPTION	REMARKS
	66 915 (CONT'D)		0000-81-7910-83	1	FITS 5 BUTTON COMBO (CLARION), 0000-81-0790	
	66 915B	ORNAMENT, TUNER	FA10-66-900	1	W/O RADIO '81 & '82 MODELS	
	66 920A	AMPLIFIER, MAIN	0000-81-142C	1	(5W X 2) (CLARION) '81 & '82 MODELS, GS	
			0000-81-132C	1	(20W X 2) (CLARION) '81 & '82 MODELS, GSI	
			0000-81-0287	1	(25W X 2) (CLARION) '82 MODEL, GSI FROM FEB. '82 PROD.	
			0000-81-142C-83	1	(5W X 2) (CLARION) '83 MODEL, S	
			0000-81-0287-83	1	(25W X 2) (CLARION) '83 MODEL, GS & GSI	
	66 920D	EQUALIZER, GRAPHIC	0000-81-0286-83	1	7 BAND (CLARION) GSI	
	66 920E	AMPLIFIER, POWER-FRONT	0000-81-0287-83	1	(25W X 2) (CLARION) GS & GSI	
	66 920F	AMPLIFIER, POWER-REAR	0000-81-0287-83	1	(25W X 2) (CLARION) '82 MODEL, GSI FROM FEB. '82 PROD.	
	66 920G	BALANCER, STICK	0000-81-0093	1	4-WAY BALANCER (CLARION) '82 & '83 MODELS, GSI	
	66 930	ANTENNA	FA01-66-930C	1	'81 - '82 MODEL	FB331 ..500001-717535
			FA42-66-930A	1	'83 MODEL	FB331 ..717536-
	66 935	FEEDER-ANTENNA	8869-66-936A	1		
	66 941	POLE, ANTENNA	FA01-66-941A	1	'81 - '82 MODEL	FB331 ..500001-717535
			FA42-66-941A	1	'83 MODEL	FB331 ..717536-
	66 944A	WIRE	FA01-66-944	1	'83 MODEL	FB331 ..717536-
	66 945	PIPE	FA42-66-945	1	'83 MODEL	FB331 ..717536-
	66 946	BAND	FA01-66-946	1		
	66 947	RELAY, ANTENNA	FA01-66-947	1		
	66 948	SWITCH, BI-METAL	FA01-66-948	1		
	66 960C	SPEAKER, LOUD-FRONT	0000-81-5210-01	2	4 DUAL CONE	
	66 970	SPEAKER, LOUD-REAR	0000-81-0643	2	5 SINGLE CONE	
			0000-81-5216-01	2	6 1/2 COAXIAL	
	66 970G	CORD, SHORT	FA07-66-970	1	'82 & '83 MODELS	FB331 ..633361-
	66 975	CORD, LOUD SPEAKER	FA05-66-970B	1	(USE W/FULL CONTROL)	
			8980-66-961	1	(USE W/ AM/FM MPX) '81 & '82 MODELS	FB331 ..500001-633360
			FA09-66-970A	1	(USE W/ AM/FM MPX) '82 & '83 MODELS	FB331 ..633361-
	66 980C	GRILLE, SPEAKER	1247-66-980	2	'81 & '82 MODELS	
	67 242A	DIODE	FA01-67-242	2	'82 & '83 MODELS	

6680A-3 AUDIO SYSTEM

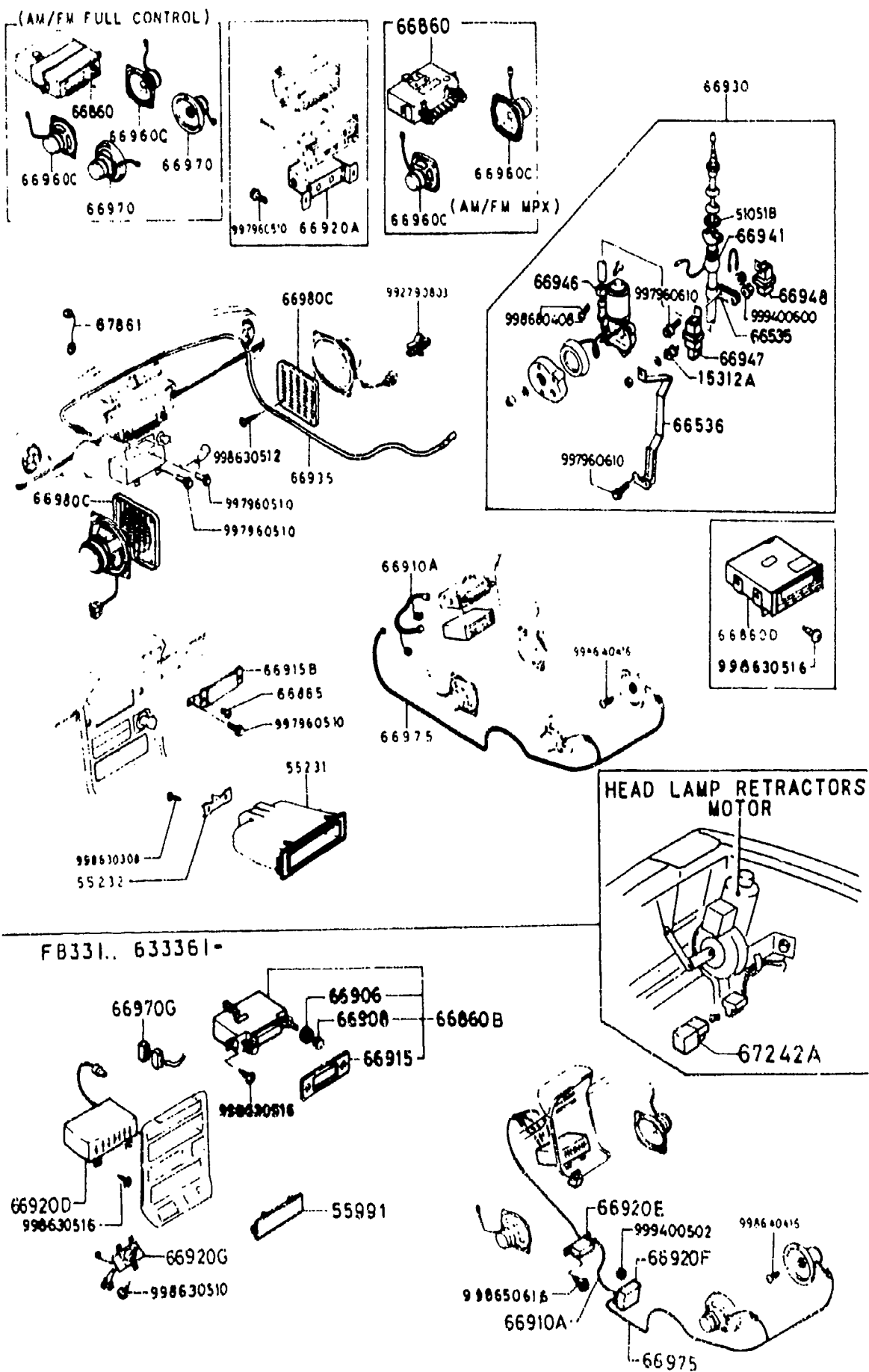

ITEM NO.	D-CODE	DESCRIPTION	PART NO.	QTY	MODEL/DESCRIPTION	REMARKS
	67 861	WIRE, RADIO-EARTH	0710-66-868A	1		

6700A-1 WIRE HARNESS (FRONT & REAR)

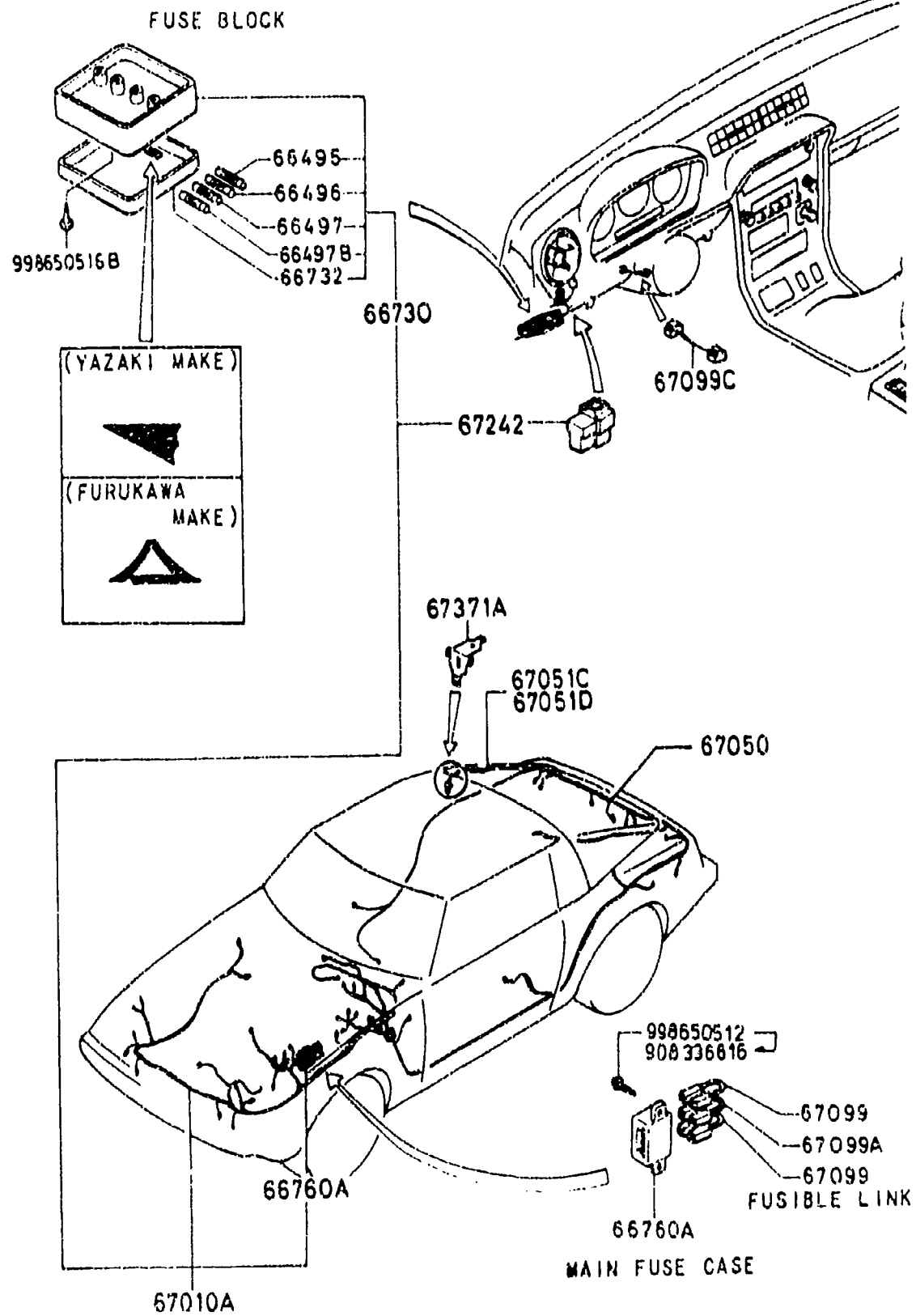

SECTION NO.	SECTION NAME
6700A	WIRE HARNESS (FRONT & REAR)
6701A	WIRE HARNESS (ENGINE & T/MISSION)
6702A	WIRE HARNESS (DASHBOARD)
6703A	WIRE HARNESS (DOOR, FLOOR & CEILING)
6704A	WIRE HARNESS CLAMP

ITEM NO.	D-CODE	DESCRIPTION	PART NO.	QTY	MODEL/DESCRIPTION	REMARKS
66 495		FUSE (10A)	9970-51-110	9	'81 MODEL	
			< AN > 0000-11-001	8	'82 & '83 MODELS	
66 496		FUSE (15A)	9970-51-115	5	'81 MODEL	
			< AN > 0000-11-0015	5	'82 & '83 MODELS	
66 497		FUSE (20A)	9970-51-120	2	'81 MODEL	
			< AN > 0000-11-002	4	'82 & '83 MODELS	
66 497B		FUSE (30A)	9970-51-130	1	'81 MODEL	
			< AN > 0000-11-003	1	'82 & '83 MODELS	
66 730		BLOCK, FUSE	FA01-66-730B	1	(INCLUDED IN FRONT HARNESS)	
66 732		COVER	FA01-66-731	1	(FURUKAWA MAKE) '81 MODEL	FB331 ..500001-508072
			FA01-66-731B	1	(FURUKAWA MAKE) '81 MODEL	FB331 ..508073-
			FA01-66-732	1	(YAZAKI MAKE) '81 MODEL	FB331 ..500001-508072
			FA01-66-732B	1	(YAZAKI MAKE) '81 MODEL	FB331 ..508073-
			FA01-66-731B	1	(FURUKAWA MAKE) '82 & '83 MODELS	
			FA01-66-732B	1	(YAZAKI MAKE) '82 & '83 MODELS	
66 760A		CASE, MAIN FUSE	8871-66-760	1	(INCLUDED IN FRONT HARNESS) '81 MODEL	
67 010A		HARNESS, FRONT	FA01-67-010E	1	'81 MODEL	FB331 ..500001-600000
			FA30-67-010D	1	'82 MODEL	FB331 ..600001-622565
			FA42-67-010A	1	'83 MODEL	
67 050		HARNESS, REAR	FA01-67-050D	1		
67 051C		CORD, REAR DEFOGGER	8341-67-051A	1		
67 051D		CORD, REAR DEFOGGER	1480-67-051B	1	(USE W REAR WIPER)	FB331 ..500001-503135
			8341-67-051A	1	(W O REAR WIPER)	
67 099		LINK, FUSIBLE	8871-67-099	2	(10M OHM) (BROWN)	
67 099A		LINK, FUSIBLE	3777-67-099	1	(7M OHM) (BLACK)	
67 099C		LINK, FUSIBLE	FA02-67-099	1	'81 MODEL	
67 242		RECTIFIER	8871-67-242	1	'81 MODEL	
67 371A		TERMINAL	8871-67-371	2	(USE W REAR WIPER)	

6701A-1

**WIRE HARNESS
(ENGINE & TRANSMISSION)**

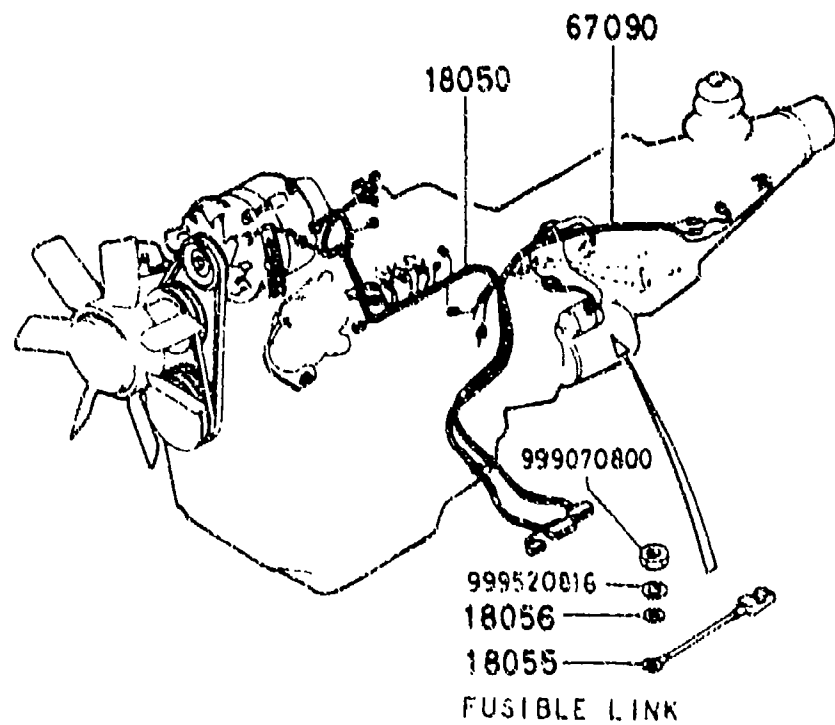
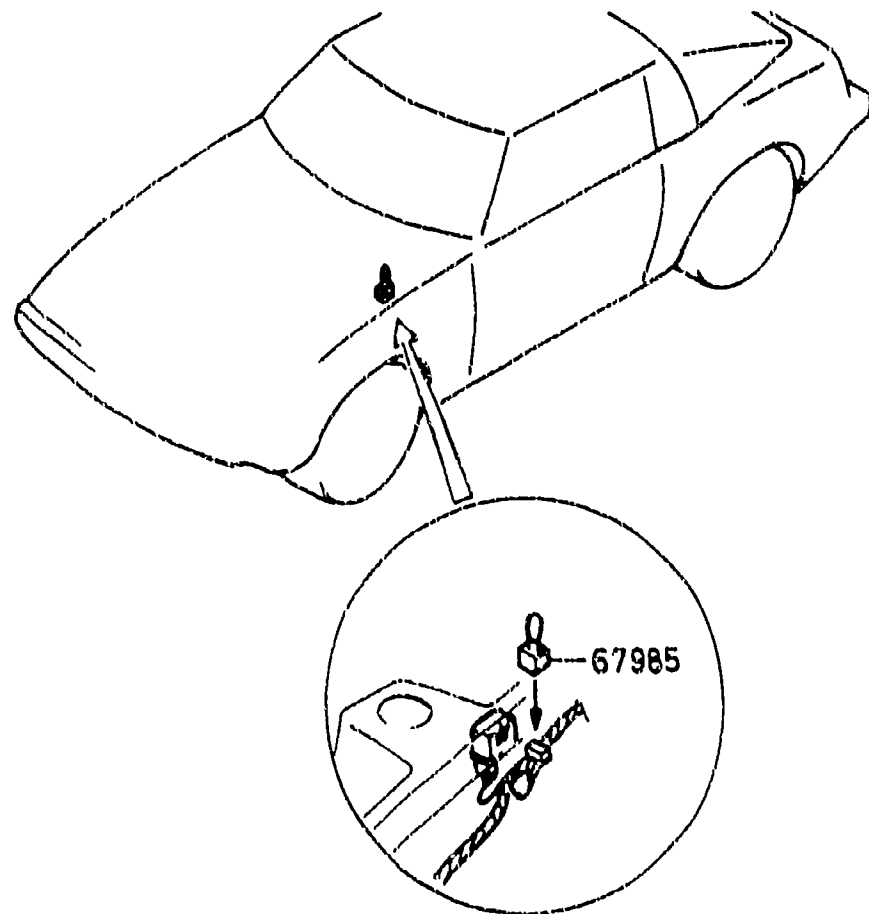

ITEM NO.	D-CODE	DESCRIPTION	PART NO.	QTY	MODEL/DESCRIPTION	REMARKS
18 050		WIRING, ENGINE	N201-18-050A	1	'81 & '82 MODELS	
			N231-18-050B	1	'83 MODEL	
18 055		LINK, FUSIBLE	8341-18-055	1		
18 056		WASHER, LOCK	8872-18-056	1	A-T	
67 090		HARNESS, TRANSMISSION	FA01-67-090B	1	M T	
			FA03-67-090C	1	A-T	
67 985		CONNECTOR, SHORT	8342-67-985	1	'81 & '82 MODELS	

SECTION INDEX -- BODY

STARTING LOCATION	SECT. NO.	SECTION NAME	STARTING LOCATION	SECT. NO.	SECTION NAME	STARTING LOCATION	SECT. NO.	SECTION NAME
2 - C 3	0900A	KEY SETS	2 - F 8	6142A	COMPRESSOR MOUNTING KIT, COMPRESSOR/CLUTCH ASSEMBLY & REPAIR PARTS ('81 MODEL)	2 - H 11	6870A	SERVICE TOOLS
2 - D 3	5000A	FRONT BUMPER	2 - F 8	6142AB	COMPRESSOR MOUNTING KIT, COMPRESSOR/CLUTCH ASSEMBLY & REPAIR PARTS ('82 MODEL)	2 - I 11	6900A	VISOR, ASSIST HANDLE & MIRRORS
2 - E 3	5005A	RADIATOR GRILLE	2 - G 8	6142AC	COMPRESSOR MOUNTING KIT, COMPRESSOR/CLUTCH ASSEMBLY & REPAIR PARTS ('83 MODEL)	2 - L 11	6930A	CAUTION PLATES
2 - F 3	5010A	REAR BUMPER	2 - H 8	6152A	EVAPORATOR PACKAGE ('81 MODEL)			
2 - G 3	5030A	WINDOW MOULDINGS	2 - I 8	6152AB	EVAPORATOR PACKAGE ('82 MODEL)			
2 - H 3	5040A	BODY MOULDINGS	2 - J 8	6152AC	EVAPORATOR PACKAGE ('83 MODEL)			
2 - I 3	5060A	SIDE PROTECTORS	2 - K 8	6230A	BACK DOOR MECHANISM			
2 - J 3	5100A	HEAD LAMPS	2 - L 8	6300A	WINDOW GLASSES			
2 - K 3	5103A	HEAD LAMP RETRACTORS	2 - M 8	6330A	SUNROOF (GSU)			
2 - L 3	5105A	FRONT COMBINATION & SIDE TURN LAMPS	2 - N 8	6600A	SWITCH & RELAY (ENGINE & TRANSMISSION)			
2 - M 3	5110A	REAR COMBINATION LAMPS	2 - C 9	6610A	DASHBOARD SWITCHES (MANUAL OPERATING)			
2 - N 3	5120A	LICENSE & REAR SIDE TURN LAMPS	2 - D 9	6611A	COMBINATION SWITCH			
2 - C 4	5125A	INTERIOR LAMPS (GS & GSU)	2 - E 9	6615A	POWER WINDOW SWITCH			
2 - D 4	5170A	ORNAMENTS	2 - F 9	6620A	DOOR, PARKING LAMP & KICK DOWN SWITCH			
2 - E 4	5180A	COWL & EXTRACTOR GRILLES	2 - G 9	6630A	RELAY (BODY)			
2 - F 4	5230A	HOOD	2 - H 9	6635A	HORN			
2 - G 4	5310A	BODY PANELS (FRONT)	2 - I 9	6640A	AUTO CRUISE CONTROL			
2 - I 4	5340A	BODY PANELS (SIDE & ROOF)	2 - J 9	6680A	AUDIO SYSTEM			
2 - J 4	5360A	BODY PANELS (FLOOR)	2 - M 9	6700A	WIRE HARNESS (FRONT & REAR)			
2 - K 4	5370A	FLOOR ATTACHMENTS	2 - N 9	6701A	WIRE HARNESS (ENGINE & TRANSMISSION)			
2 - L 4	5500A	DASHBOARD EQUIPMENT	2 - C 10	6702A	WIRE HARNESS (DASHBOARD)			
2 - N 4	5540A	METERS	2 - D 10	6703A	WIRE HARNESS (DOOR, FLOOR & CEILING)			
2 - C 5	5560A	DASHBOARD & RELATED	2 - E 10	6704A	WIRE HARNESS CLAMPS			
2 - E 5	5570A	CONSOLE	2 - F 10	6720A	WINDSHIELD WASHER			
2 - G 5	5580A	VENTILATOR	2 - G 10	6730A	WINDSHIELD WIPER			
2 - H 5	5700A	SEATS ('81 & '82) MODELS	2 - H 10	6740A	WIPER MOTOR (COMPONENTS ONLY)			
2 - C 6	5700AA	SEATS ('83 MODEL)	2 - I 10	6750A	REAR WINDOW WIPER & WASHER			
2 - H 6	5790A	SEAT BELTS	2 - J 10	6760A	REAR WINDOW WIPER MOTOR (COMPONENTS ONLY)			
2 - J 6	5800A	FRONT DOOR	2 - K 10	6800A	CEILING TRIM			
2 - K 6	5830A	FRONT DOOR MECHANISM	2 - C 11	6840A	TRIM & SCUFF PLATE			
2 - C 7	5840A	FRONT DOOR TRIM & RELATED PARTS	2 - F 11	6860A	FLOOR MATS & PADS			
2 - F 7	6100A	HEATER						
2 - G 7	6110A	HEATER UNIT						
2 - H 7	6115A	HEATER CONTROLS						
2 - I 7	6120A	HEATER BLOWER						
2 - J 7	6132A	CONDENSER PACKAGE ('81 MODEL)						
2 - L 7	6132AB	CONDENSER PACKAGE ('82 MODEL)						
2 - C 8	6132AC	CONDENSER PACKAGE ('83 MODEL)						

6702A-1 WIRE HARNESS (DASHBOARD)

ITEM NO.	D-CODE	DESCRIPTION	PART NO.	QTY	MODEL/DESCRIPTION	REMARKS
	67 030	HARNESS, INSTRUMENT	FA01-67-030C	1		
	67 120	HARNESS, PARKING BRAKE	FA03-67-120B	1	GSL MODEL	

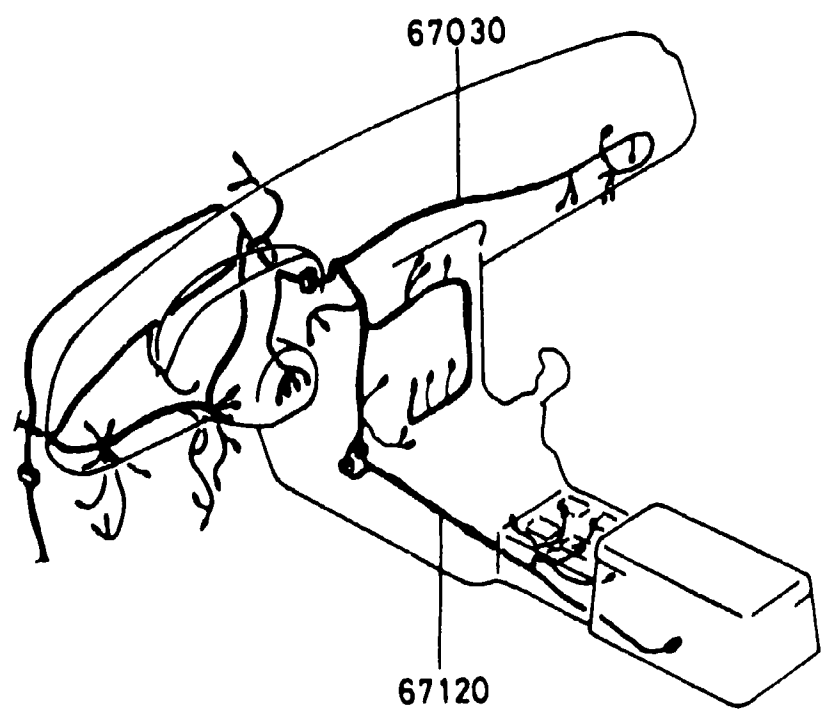

**6703A-1 WIRE HARNESS
(DOOR, FLOOR & CEILING)**

ITEM NO.	D-CODE	DESCRIPTION	PART NO.	QTY	MODEL/DESCRIPTION	REMARKS
	67 120A	HARNES, FLOOR	FA01-67-120B	1	S MODEL	
	67 190G	HARNES, DOOR	FA02-67-190A	1	GSL MODEL '81 MODEL	
				2	'82 & '83 MODELS	

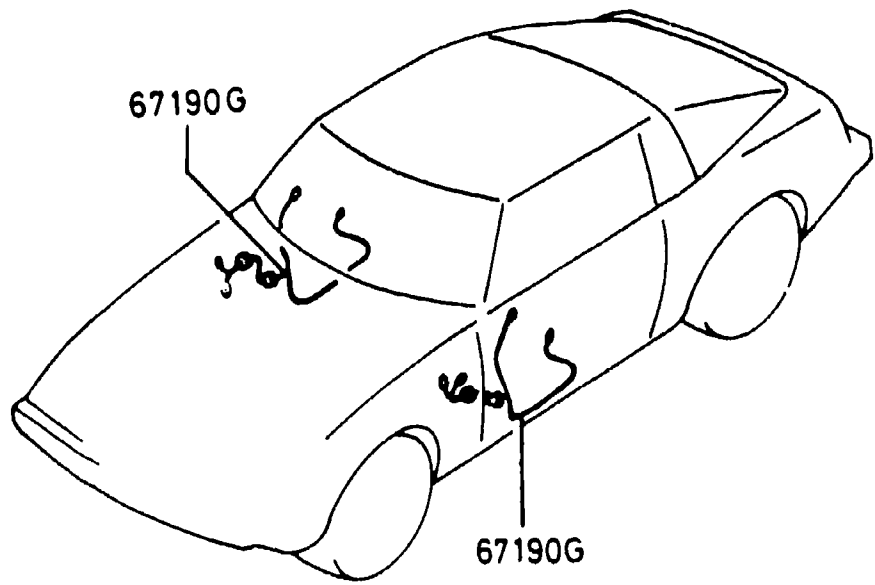
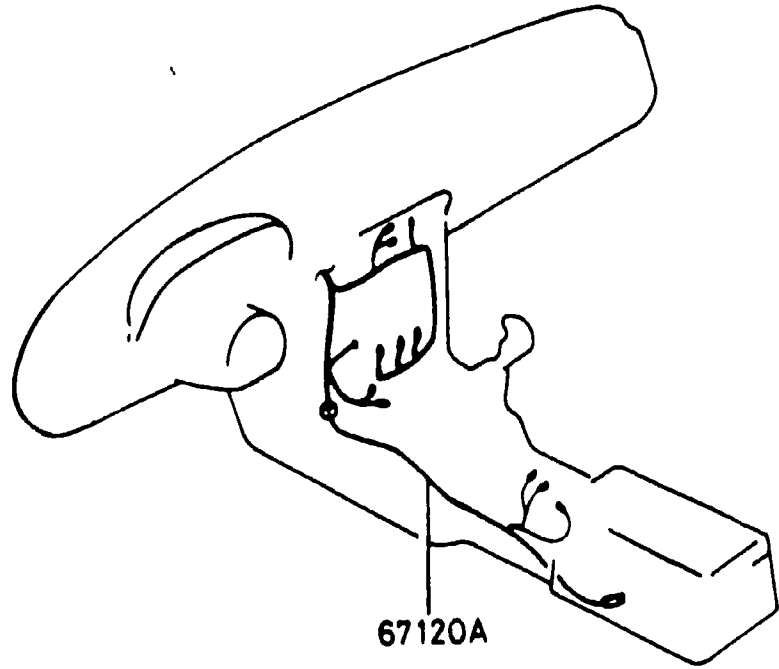

6704A-1 WIRE HARNESS CLAMPS

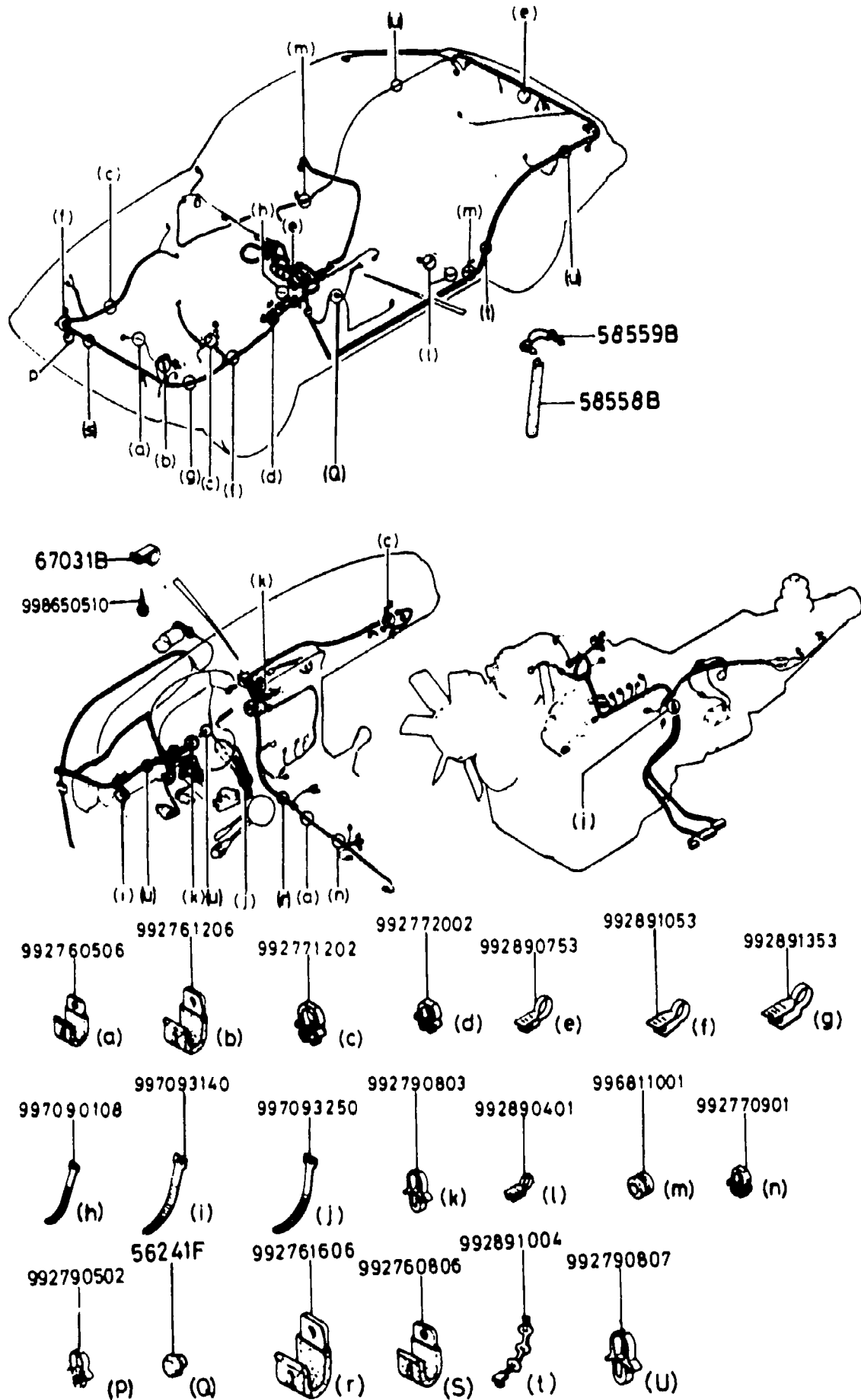

ITEM NO.	D-CODE	DESCRIPTION	PART NO.	QTY	MODEL/DESCRIPTION	REMARKS
	56 241F	PLUG, DRAIN	0118-56-241	4	S MODEL	
	58 558B	PROTECTOR, WIRE	1243-58-558	2	GSL MODEL	
	58 559B	CLIP, WIRE	1243-58-559	4	GSL MODEL	
	67 031B	CLIP	8871-67-031	1		

6720A-1 WINDSHIELD WASHER

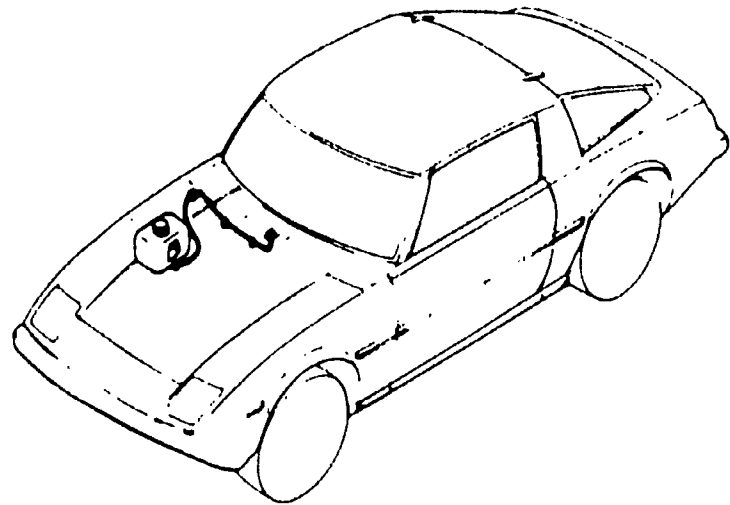

ITEM NO.	D-CODE	DESCRIPTION	PART NO.	QTY	MODEL/DESCRIPTION	REMARKS
	41 692B	PROTECTOR	0866-67-156	1		
	67 480	TANK, WASHER	2522-67-480B	1		
	67 500	PIPE	8871-67-500	1		
	67 510	NOZZLE, WASHER	1011-67-510A	1		
	67 511	PACKING	1011-67-511B	1		
	67 515	CLIP	1011-67-515B	1		
	67 521	BRACKET, WASHER TANK	8545-53-225	1		
	76 671	TANK	2522-76-671A	1		
	76 673	SWITCH, LEVEL	8173-76-673	1	'83 MODEL	
	87 992A	CAP TANK	BA02-76-673	1		
	87 993	PUMP KIT	8532-76-672	1		

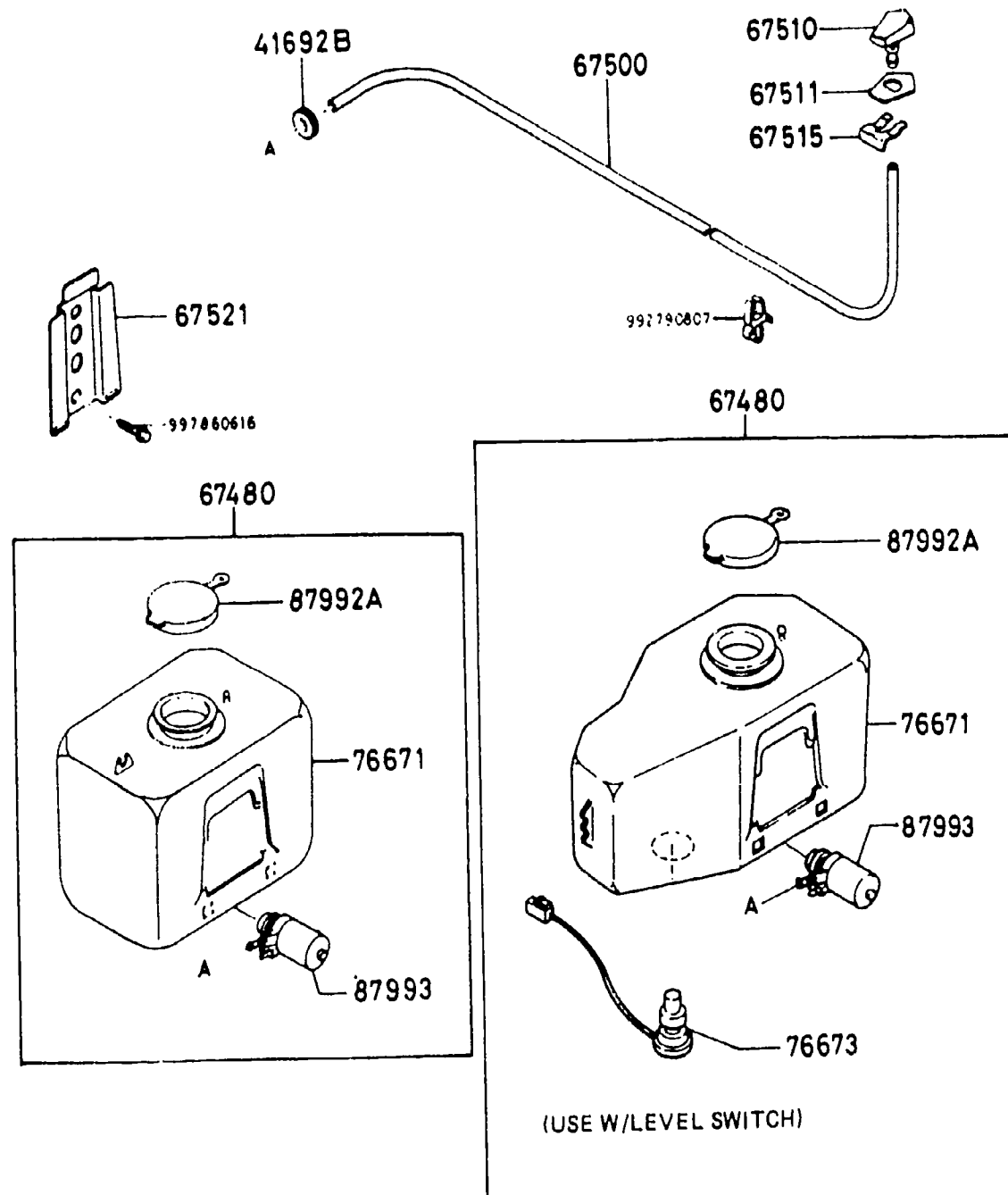

6730A-1 WINDSHIELD WIPER

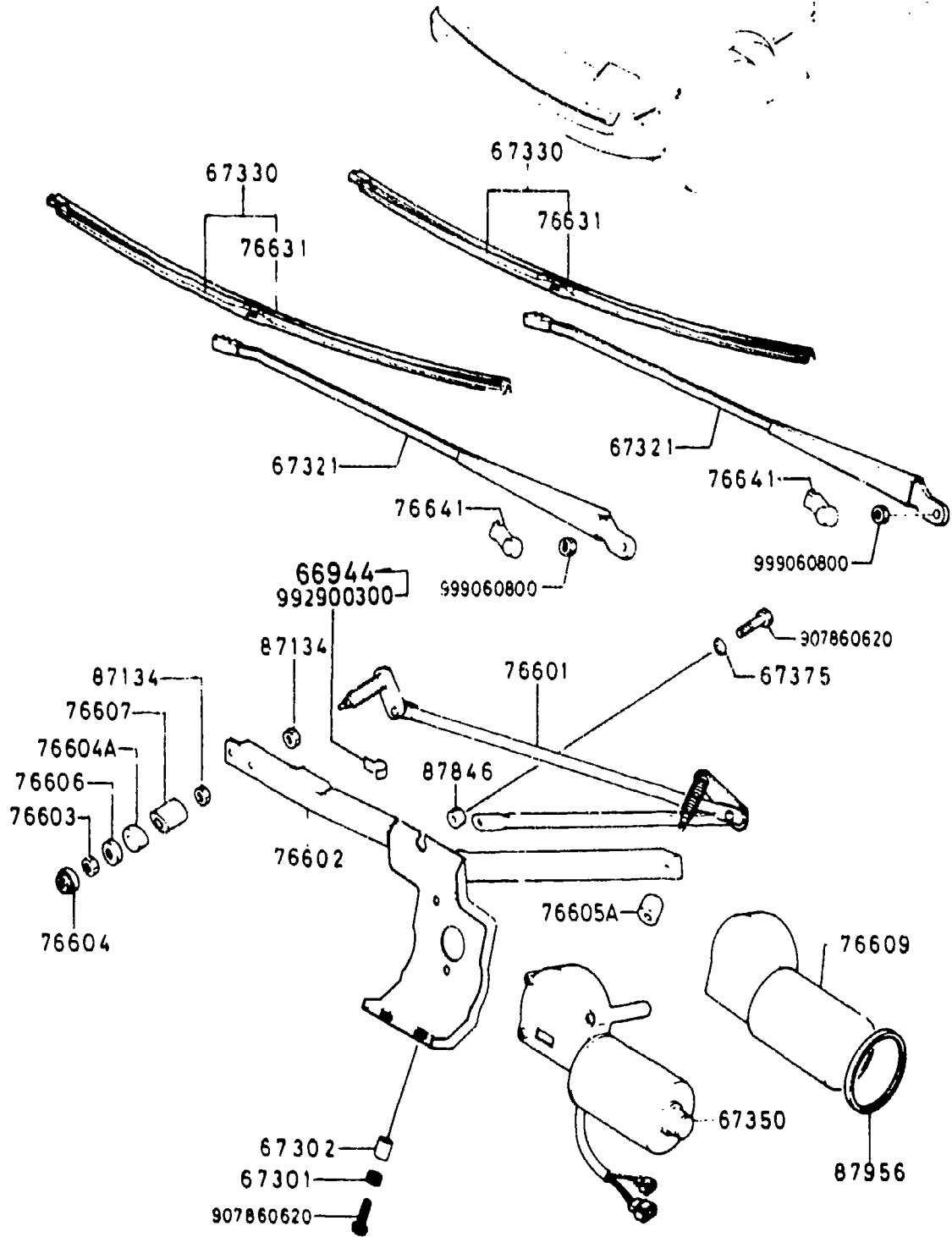
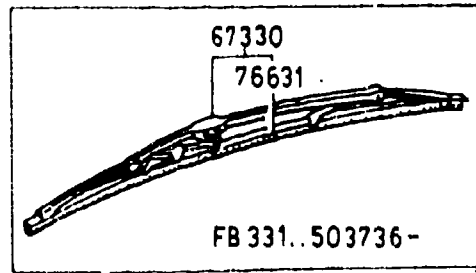

ITEM NO.	D-CODE	DESCRIPTION	PART NO.	QTY	MODEL/DESCRIPTION	REMARKS
	66 944	CLIP	0208-66-944A	1		
	67 301	WASHER, RUBBER	0866-67-301A	2		
	67 302	SPACER	0866-67-302	2		
	67 321	ARM, WIPER	8872-67-321	2		
	67 330	BLADE, WIPER	8562-67-330A	2	'81 & '82 MODELS	
			FA42-67-330	2	'83 MODEL	
	67 350	MOTOR, WIPER	8872-67-350A	1		
	67 375	WASHER, CAP	1011-67-375	2		
	76 601	LINK, WIPER	8871-76-601B	1		
	76 602	FRAME	8871-76-602B	1		
	76 603	NUT, CAP	8871-76-657	2		
	76 604	CAP, SEAL	8871-76-655A	2		
	76 604A	BUSHING, OUTER	8871-76-604A	2		
	76 605A	BUSHING, INNER	8871-76-605A	1		
	76 606	WASHER, CUP	8871-76-656A	2		
	76 607	BUSHING, INNER	8871-76-603A	1		
	76 609	COVER	1175-76-609	1		
	76 631	BLADE	F023-76-631	1	'83 MODEL	
			8562-76-631A	2	'81 & '82 MODELS	
	76 641	COVER, WIPER ARM	8871-76-641	2		
	87 134	NUT	0727-87-844	4		
	87 846	GROMMET	0824-87-846	2		
	87 956	BAND	0305-87-956	1		

**6740A-1 WIPER MOTOR
(COMPONENTS ONLY)**

COMPONENTS OF 8872 67 350

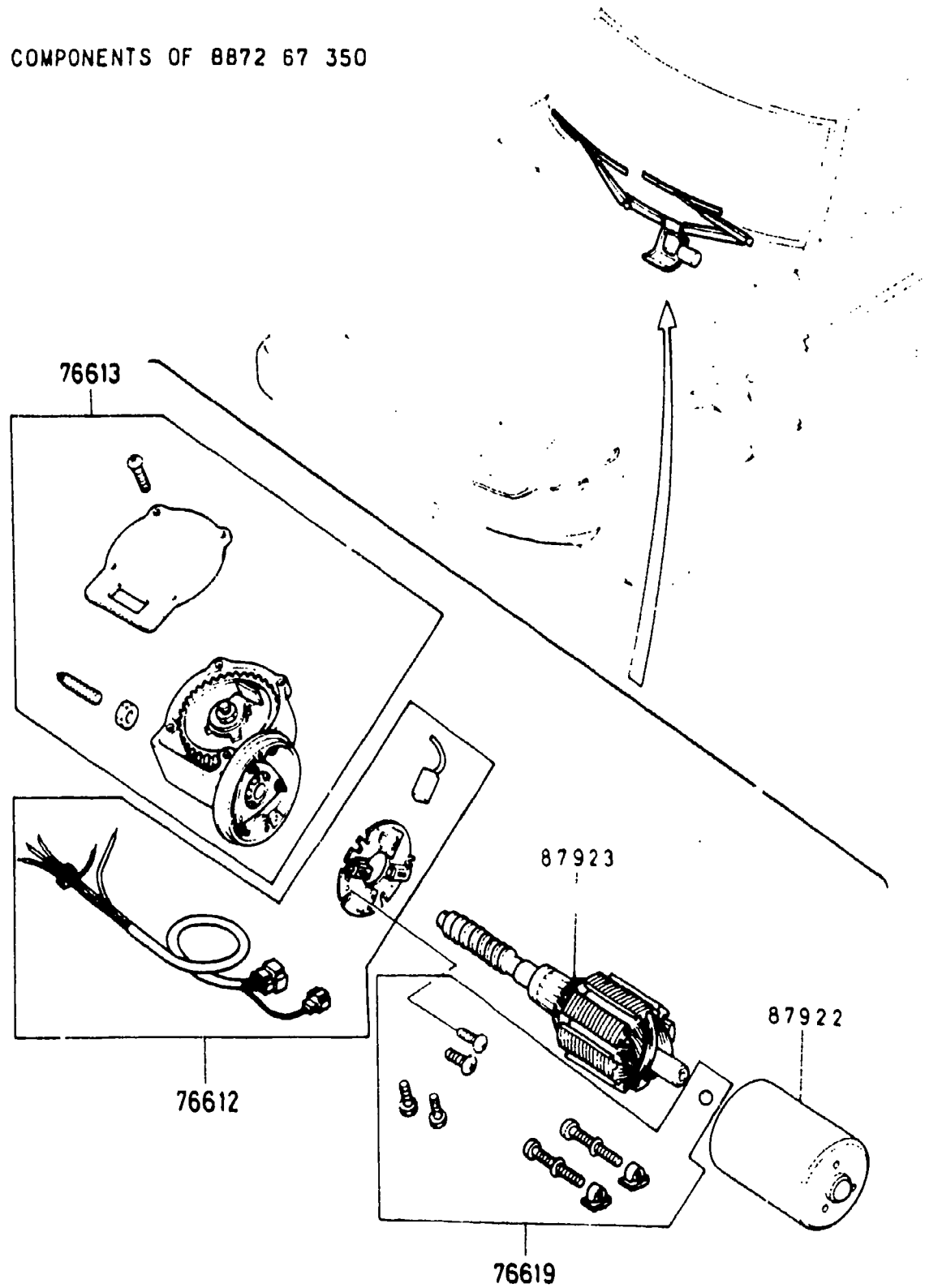

ITEM NO.	D-CODE	DESCRIPTION	PART NO.	QTY	MODEL/DESCRIPTION	REMARKS
	76 612	HOLDER ,BRUSH	8872-76-612	1		
	76 613	BOX, GEAR	8872-76-610	1	'81 & '82 MODELS	
	76 619	PARTS SET	8236-76-619A	1		
	87 922	YOKE, STATOR	8236-76-614	1	'81 & '82 MODELS	
	87 923	ROTOR	8236-76-618	1	'81 & '82 MODELS	
		REFER TO SERV. BULL. NO. 109/83, CAT. 15 FOR NEW PARTS INFO.				

6750A-1 REAR WINDOW WIPER & WASHER

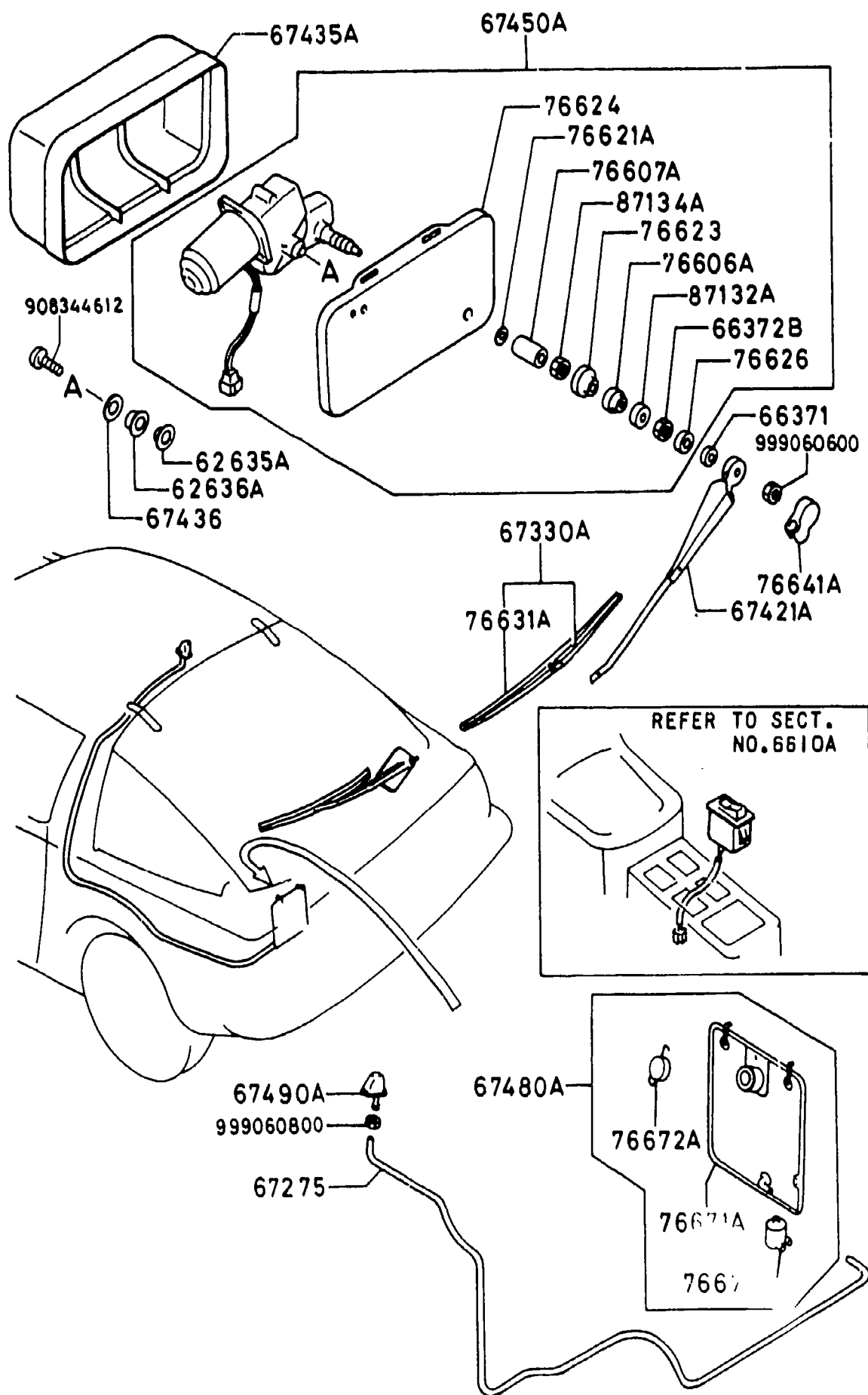

ITEM NO.	D-CODE	DESCRIPTION	PART NO.	QTY	MODEL/DESCRIPTION	REMARKS
	62 635A	NUT	8871-62-635A	1		
	62 636A	WASHER	8871-62-636A	1		
	66 371	CAP, SEAL	0212-66-371	1		
	66 372B	NUT	0212-66-372A	1		
	67 275	HOSE, 3CREW WASHER	1480-67-501A	1		
	67 330	BLADE, WIPER	8144-67-330A	1		
	67 421A	ARM, WIPER	1480-67-421A	1		
	67 435A	COVER, WIPER MOTOR	1480-67-435	1		
	67 436	SPACER	1480-67-436	1		
	67 450A	MOTOR	1480-67-450C	1		
	67 480A	TANK	1410-67-480C	1		
	67 490A	NOZZLE	1480-67-510	1		
	76 606A	BUSHING, OUTER	1480-67-606	1		
	76 607A	BUSHING, INNER	1480-76-607	1		
	76 621A	WASHER	1029-76-621	1		
	76 623	BUSHING, INNER	1480-76-623	1		
	76 624	BRACKET, WIPER MOTOR	1480-76-624A	1		
	76 626	NUT, LOCK PLATE	1480-76-626	1		
	76 631A	BLADE	8144-76-631	1		
	76 641A	COVER, WIPER, ARM	8134-76-641	1		
	76 671A	TANK, WASHER-REAR WIPER	1410-76-671	1		
	76 672	PUMP, WASHER	1410-67-530	1		
	76 672A	CAP, TANK	1410-76-672A	1		
	87 132A	WASHER	0702-87-132	1		
	87 134A	NUT	0259-87-134	1		

6760A-1

REAR WINDOW WIPER MOTOR
(COMPONENTS ONLY)

COMPONENTS OF 1480-67-450B
1480-67-450C

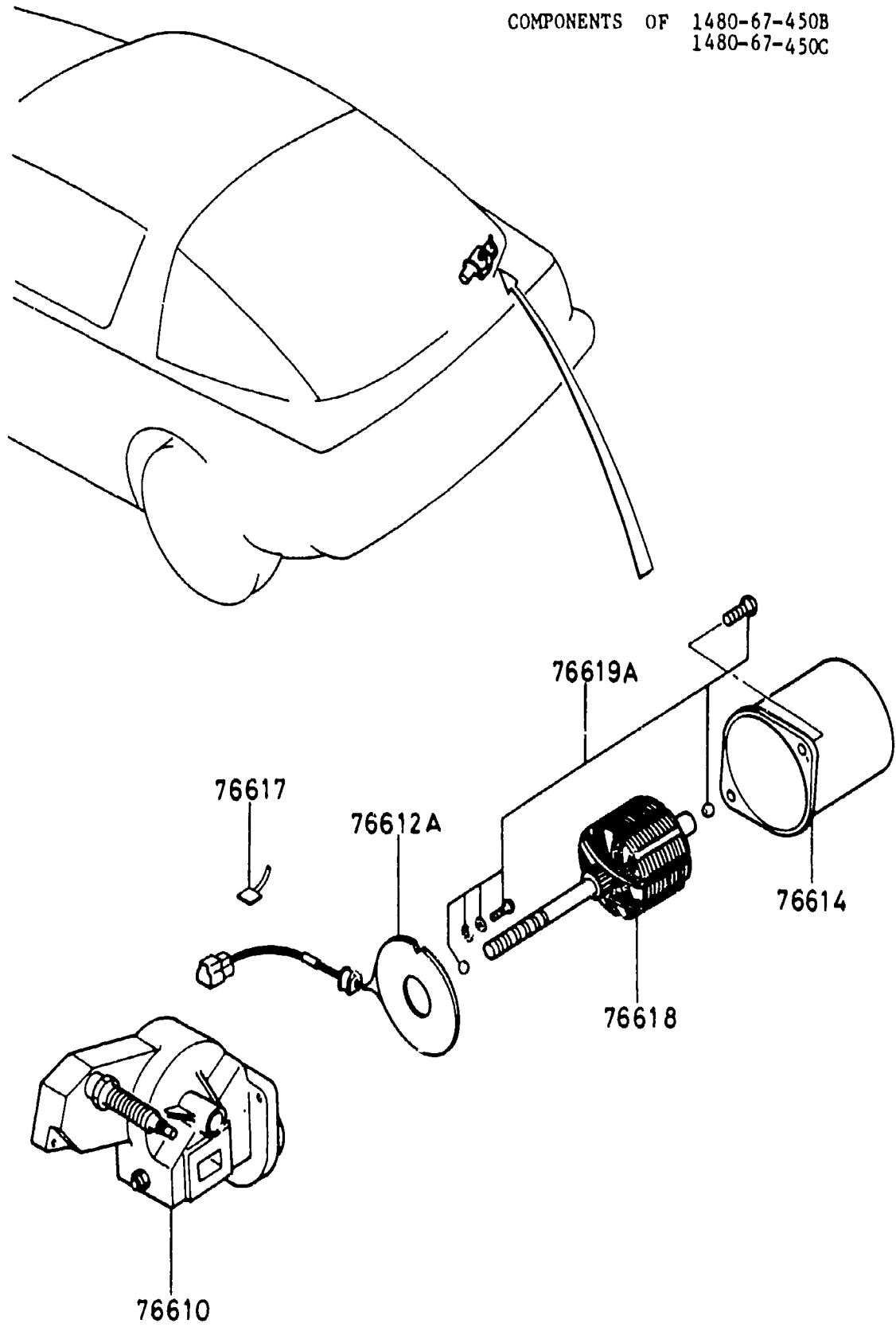

ITEM NO.	D-CODE	DESCRIPTION	PART NO.	QTY	MODEL/DESCRIPTION	REMARKS
	76 610	BOX GEAR	1480-76-610	1		
	76 612A	PLATE, HOLDER-BRUSH	1480-76-612	1		
	76 614	YOKE, STATER	8532-76-614	2		
	76 617	BRUSH	8532-76-617	2		
	76 618	ROTOR	8532-76-618	1		
	76 619A	PARTS SET	1410-76-619	1		

6800A-1 CEILING TRIM

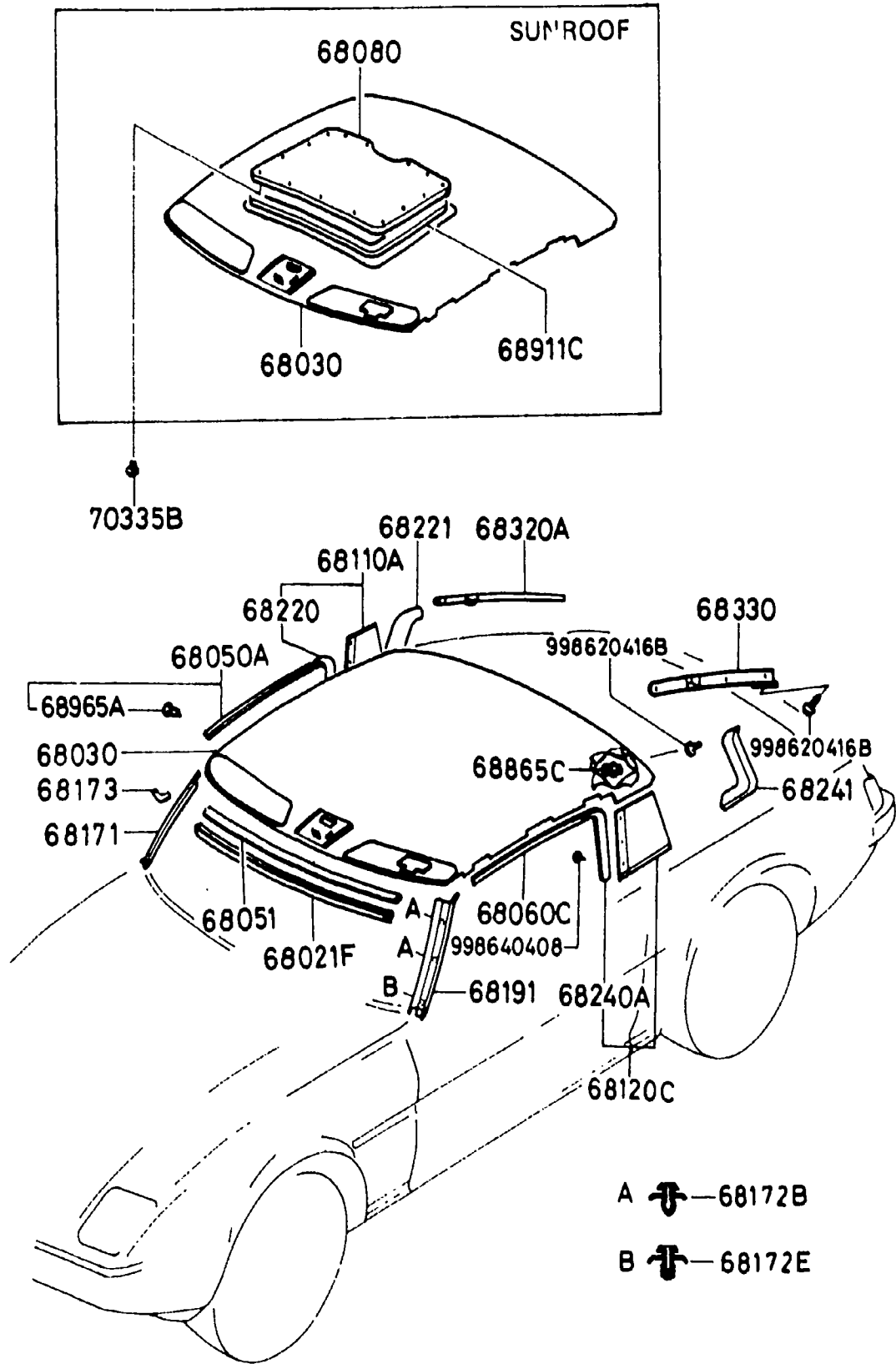

ITEM NO.	D-CODE	DESCRIPTION	PART NO.	QTY	MODEL/DESCRIPTION	REMARKS
68 021F		GARNISH, TOP-FRONT	FA01-68-021	1		
		BLACK	01			
		RED	10			
		TAN	29			
		BROWN	70			FB331 ..642606-
		BROWN	71			FB331 ..500001-642605
68 030		CEILING, TOP	FA01-68-030C	1	'81 NORM. ROOF	
		BLACK	02			
		RED	10			
		BROWN	70			
68 050A		GARNISH (R), TOP-SIDE	FA04-68-030C	1	SUNROOF	
			FA01-68-960C	1		
		BLACK	00			
		RED	11			
		TAN	29			
		BROWN	70			
68 051		PLATE, CEILING-FRONT	8871-53-041	1		
68 060C		GARNISH (L), TOP-SIDE	FA01-68-970B	1		
		BLACK	00			
		RED	11			
		TAN	29			
		BROWN	70			
68 080		CEILING, TOP	FA04-68-070A	1	SUNROOF	
		BLACK	02			
		RED	10			
		TAN	28			
		BROWN	70			
68 110A		TRIM (R), CENTER PILLAR	FA01-68-110A	1		
		BLACK	00			
		RED	11			
		TAN	29			
		BROWN	70			
68 120C		TRIM (L), CENTER PILLAR	FA01-68-120A	1		
		BLACK	00			
		RED	11			
		TAN	29			
		BROWN	70			
68 171		TRIM (R), FRONT PILLAR	FA01-68-710	1		
		BLACK	00			
		RED	11			

6800A-2 CEILING TRIM

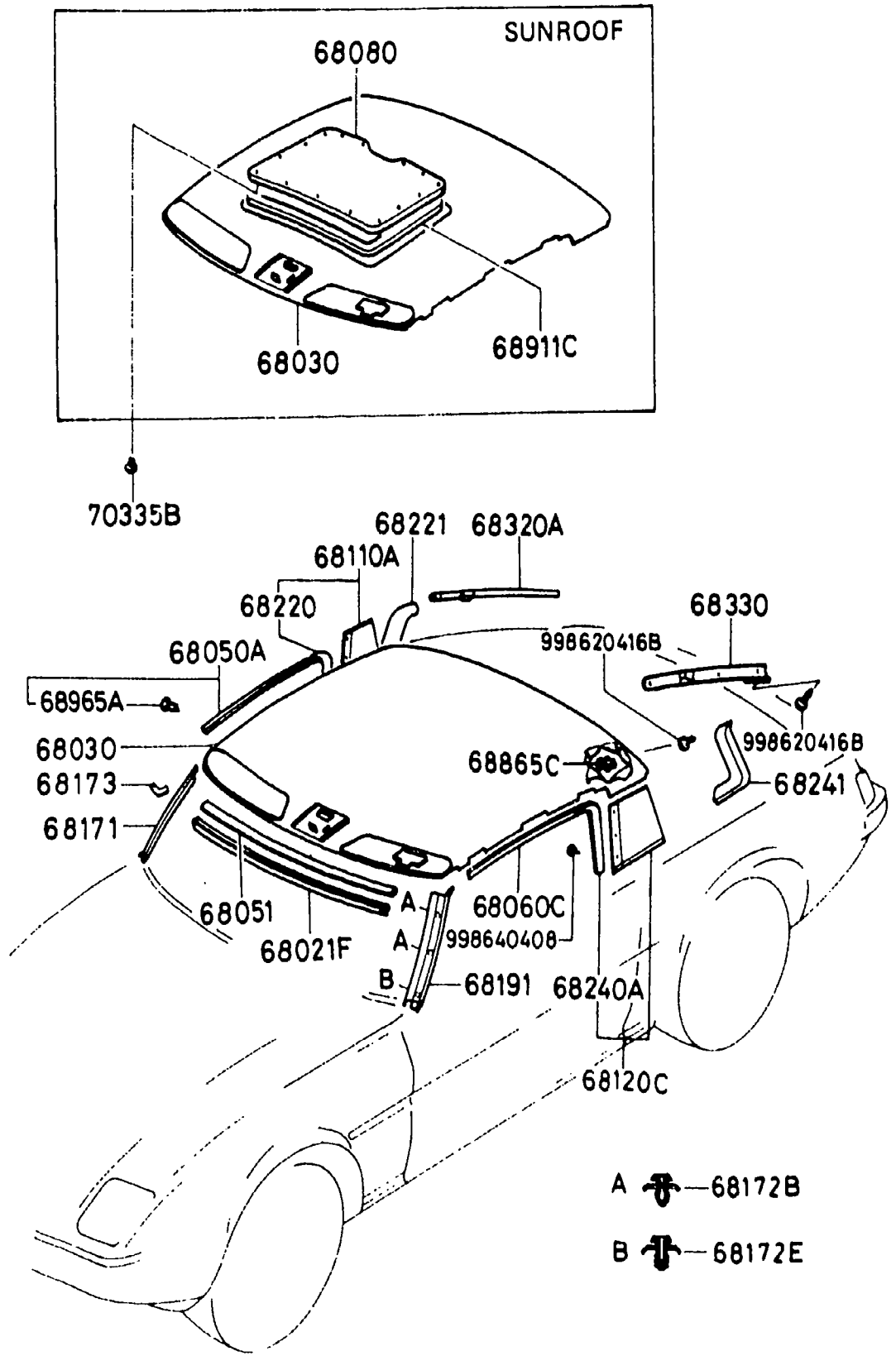

ITEM NO.	D-CODE	DESCRIPTION	PART NO.	QTY	MODEL/DESCRIPTION	REMARKS
68 171	(CONT'D)	TAN	29			
		BROWN	70			
68 172B		FASTENER, FRT. P/TRIM	G001-68-172	6	'81 MODEL	FB331 ..500001-533893
				4		FB331 ..533894-
68 172E		FASTENER, FRT. P/TRIM	FA01-68-172	2		FB331 ..533894-
68 173		SEALER, UPPER	8871-68-175	2		
68 191		TRIM (L), FRT. PILLAR	FA01-68-190	1		
		BLACK	00			
		RED	11			
		TAN	29			
		BROWN	70			
68 220		GARNISH (R), CTR. TRIM	FA01-68-981	1		
		BLACK	00			
		RED	11			
		TAN	29			
		BROWN	70			
68 221		TRIM (R), CTR. PILLAR	8871-68-221A	1		
		BLACK	00			
		RED	11			
		TAN	29			
		BROWN	70			
68 240A		GARNISH (L), CTR. TRIM	FA01-68-991	1		
		BLACK	00			
		RED	11			
		TAN	29			
		BROWN	70			
68 241		TRIM (L), CTR. PILLAR	8871-68-241A	1		
		BLACK	00			
		RED	11			
		TAN	29			
		BROWN	70			
68 320A		TRIM (R), REAR PILLAR	8871-68-271A	1		
		BLACK	00			
		RED	11			
		TAN	29			
		BROWN	70			
68 330		TRIM (L), REAR PILLAR	8871-68-291A	1		
		BLACK	00			
		RED	11			
		TAN	29			

6800A-3 CEILING TRIM

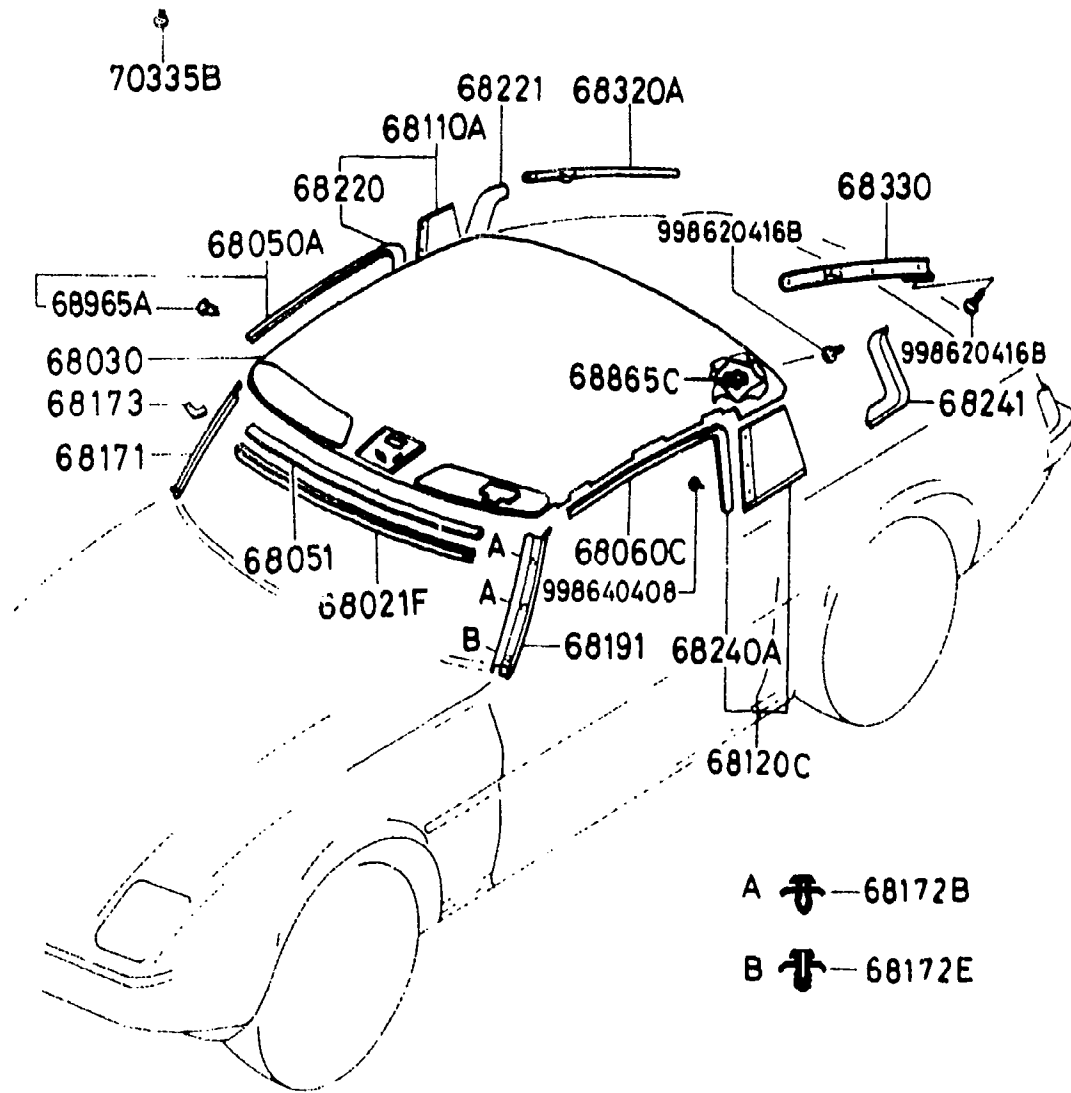
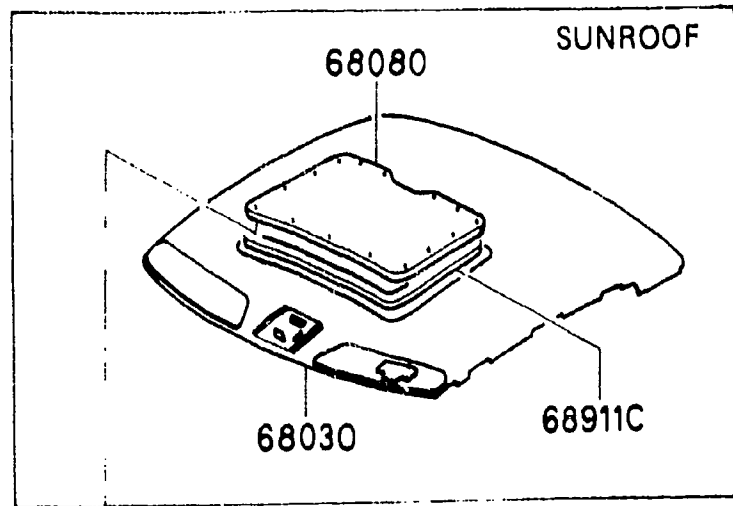

ITEM NO.	D-CODE	DESCRIPTION	PART NO.	QTY	MODEL/DESCRIPTION	REMARKS
68 330 (CONT'D)		BROWN	70			
68 865C		FASTENER	B006-68-865	8		
68 911C		WELT, SEAMING	FA01-68-029A	1	SUNROOF	
68 965A		FASTENER	FA56-68-965	6		
70 335B		CLIP, CEILING	0305-70-335	4	NORM. ROOF	
				20	SUNROOF	

SECTION INDEX -- BODY

STARTING LOCATION	SECT. NO.	SECTION NAME	STARTING LOCATION	SECT. NO.	SECTION NAME	STARTING LOCATION	SECT. NO.	SECTION NAME
2 - C 3	0900A	KEY SETS	2 - E 8	6142A	COMPRESSOR MOUNTING KIT, COMPRESSOR/CLUTCH ASSEMBLY & REPAIR PARTS ('81 MODEL)	2 - 111	6900A	VISOR, ASSIST HANDLE & MIRRORS
2 - D 3	5000A	FRONT BUMPER	2 - F 8	6142AB	COMPRESSOR MOUNTING KIT, COMPRESSOR/CLUTCH ASSEMBLY & REPAIR PARTS ('82 MODEL)	2 - 111	6930A	CAUTION PLATES
2 - E 3	5005A	RADIATOR GRILLE	2 - G 8	6142AC	COMPRESSOR MOUNTING KIT, COMPRESSOR/CLUTCH ASSEMBLY & REPAIR PARTS ('83 MODEL)			
2 - F 3	5010A	REAR BUMPER	2 - H 8	6152A	EVAPORATOR PACKAGE ('81 MODEL)			
2 - G 3	5030A	WINDOW MOULDINGS	2 - I 8	6152AB	EVAPORATOR PACKAGE ('82 MODEL)			
2 - H 3	5040A	BODY MOULDINGS	2 - J 8	6152AC	EVAPORATOR PACKAGE ('83 MODEL)			
2 - I 3	5060A	SIDE PROTECTORS	2 - K 8	6230A	BACK DOOR MECHANISM			
2 - J 3	5100A	HEAD LAMPS	2 - L 8	6300A	WINDOW GLASSES			
2 - K 3	5103A	HEAD LAMP RETRACTORS	2 - M 8	6330A	SUNROOF (GSI)			
2 - L 3	5105A	FRONT COMBINATION & SIDE TURN LAMPS	2 - N 8	6600A	SWITCH & RELAY (ENGINE & TRANSMISSION)			
2 - M 3	5110A	REAR COMBINATION LAMPS	2 - C 9	6610A	DASHBOARD SWITCHES (MANUAL OPERATING)			
2 - N 3	5120A	LICENSE & REAR SIDE TURN LAMPS	2 - D 9	6611A	COMBINATION SWITCH			
2 - C 4	5125A	INTERIOR LAMPS (GS & GSI)	2 - E 9	6615A	POWER WINDOW SWITCH			
2 - D 4	5170A	ORNAMENTS	2 - F 9	6620A	DOOR, PARKING LAMP & KICK DOWN SWITCH			
2 - E 4	5180A	COWL & EXTRACTOR GRILLES	2 - G 9	6630A	RELAY (BODY)			
2 - F 4	5230A	HOOD	2 - H 9	6635A	HORN			
2 - G 4	5310A	BODY PANELS (FRONT)	2 - I 9	6640A	AUTO CRUISE CONTROL			
2 - I 4	5340A	BODY PANELS (SIDE & ROOF)	2 - J 9	6680A	AUDIO SYSTEM			
2 - J 4	5360A	BODY PANELS (FLOOR)	2 - M 9	6700A	WIRE HARNESS (FRONT & REAR)			
2 - K 4	5370A	FLOOR ATTACHMENTS	2 - N 9	6701A	WIRE HARNESS (ENGINE & TRANSMISSION)			
2 - L 4	5500A	DASHBOARD EQUIPMENT	2 - C 10	6702A	WIRE HARNESS (DASHBOARD)			
2 - N 4	5540A	METERS	2 - D 10	6703A	WIRE HARNESS (DOOR, FLOOR & CEILING)			
2 - C 5	5560A	DASHBOARD & RELATED	2 - E 10	6704A	WIRE HARNESS CLAMPS			
2 - E 5	5570A	CONSOLE	2 - F 10	6720A	WINDSHIELD WASHER			
2 - G 5	5580A	VENTILATOR	2 - G 10	6730A	WINDSHIELD WIPER			
2 - H 5	5700A	SEATS ('81 & '82) MODELS	2 - H 10	6740A	WIPER MOTOR (COMPONENTS ONLY)			
2 - C 6	5700AA	SEATS ('83 MODEL)	2 - I 10	6750A	REAR WINDOW WIPER & WASHER			
2 - H 6	5790A	SEAT BELTS	2 - J 10	6760A	REAR WINDOW WIPER MOTOR (COMPONENTS ONLY)			
2 - J 6	5800A	FRONT DOOR	2 - K 10	6800A	CEILING TRIM			
2 - K 6	5830A	FRONT DOOR MECHANISM	2 - C 11	6840A	TRIM & SCUFF PLATE			
2 - C 7	5840A	FRONT DOOR TRIM & RELATED PARTS	2 - F 11	6860A	FLOOR MATS & PADS			
2 - F 7	6100A	HEATER	2 - H 11	6870A	SERVICE TOOLS			
2 - G 7	6110A	HEATER UNIT						
2 - H 7	6115A	HEATER CONTROLS						
2 - I 7	6120A	HEATER BLOWER						
2 - J 7	6132A	CONDENSER PACKAGE ('81 MODEL)						
2 - L 7	6132AB	CONDENSER PACKAGE ('82 MODEL)						
2 - C 8	6132AC	CONDENSER PACKAGE ('83 MODEL)						

6840A-1 TRIM & SCUFF PLATE

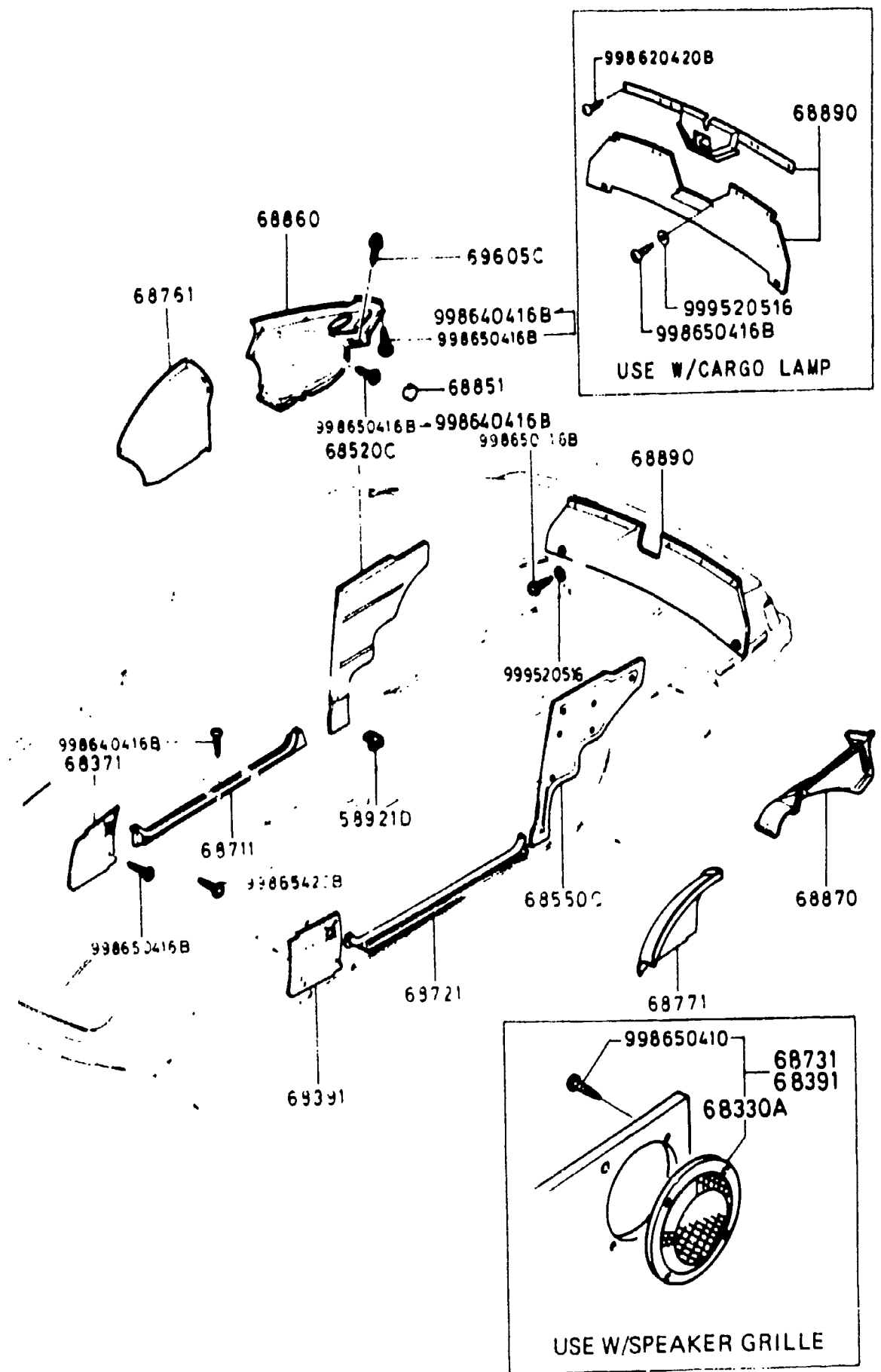

ITEM NO.	D-CODE	DESCRIPTION	PART NO.	QTY	MODEL/DESCRIPTION	REMARKS
	58 921D	FASTENER	0208-58-921	10		
	68 330A	GRILLE, SPEAKER	FA07-66-980	2	'83 MODEL	
	68 371	TRIM (R), FRONT SIDE	FA03-68-370	1	'81 & '82 MODELS	
		RED	12			
		TAN	72			
		BLACK	77			
		BROWN	85			
			FA42-68-370	1	'83 MODEL	
		RED	12			
		TAN	72			
		BLACK	77			
		BROWN	85			
	68 391	TRIM (L), FRONT SIDE	FA03-68-390	1	'81 & '82 MODELS	
		RED	12			
		TAN	72			
		BLACK	77			
		BROWN	85			
			FA42-68-390	1	'83 MODEL	
		RED	12			
		TAN	72			
		BLACK	77			
		BROWN	85			
	68 520C	TRIM (R), QUARTER	FA01-68-520D	1	(VINYL)	
		BLACK	01			
		RED	10			
		BROWN	70			
			FA02-68-520E	1	(CLOTH)	FB331 ..500001-600000
			FA04-68-520D	1	(LEATHER)	
		RED	10			
		TAN	29			
		BROWN	70			
	68 550C	TRIM (L), QUARTER	FA01-68-550D	1	(VINYL)	
		BLACK	01			
		RED	10			
		BROWN	70			
			FA02-68-550E	1	(CLOTH)	
		BLACK	00			
		RED	10			
		BROWN	70			
			FA04-68-550D	1	(LEATHER)	

6840A-2 TRIM & SCUFF PLATE

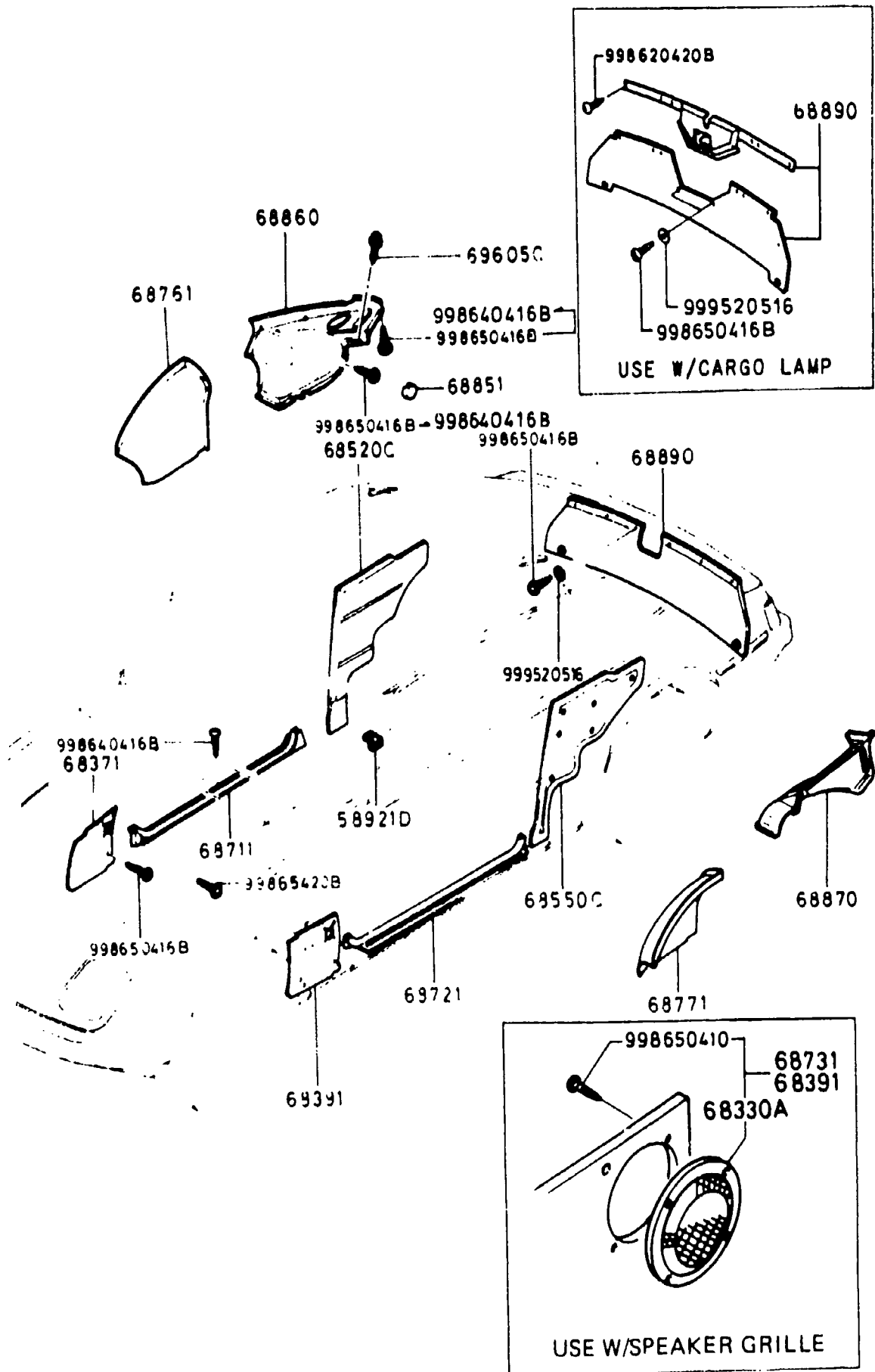

ITEM NO.	D-CODE	DESCRIPTION	PART NO.	QTY	MODEL/DESCRIPTION	REMARKS
68 550C	(CONT'D)	RED	10			
		BROWN	70			
68 711		PLATE (R), FRONT SCUFF	8871-68-710	1		
		BLACK	00			
		RED	10			
		TAN	29			
		BROWN	70			
68 721		PLATE (L), FRONT SCUFF	8871-68-720	1		
		BLACK	00			
		RED	10			
		TAN	29			
		BROWN	70			
68 761		TRIM (R), TIRE HOUSE	8871-68-770	1		
		BLACK	00			
		RED	11			
		TAN	29			
		BROWN	70			
68 771		TRIM (L), TIRE HOUSE	8871-68-790	1		
		BLACK	00			
		RED	11			
		TAN	29			
		BROWN	70			
68 851		CAP, TRUNK SIDE TRIM	8871-68-851	4		
		BLACK	00			
		RED	11			
		BROWN	70			
		TAN	71			
68 860		TRIM (R), TRUNK SIDE	8871-68-861A	1		
		BLACK	00			
		RED	11			
		TAN	29			
		BROWN	70			
68 870		TRIM (L), TRUNK SIDE	8871-68-871A	1		
		BLACK	00			
		RED	11			
		TAN	29			
		BROWN	70			
68 890		TRIM, TRUNK END	1480-68-890C	1	(USE W/ CARGO RR. LAMP)	
		BLACK	00			

6840A-3 TRIM & SCUFF PLATE

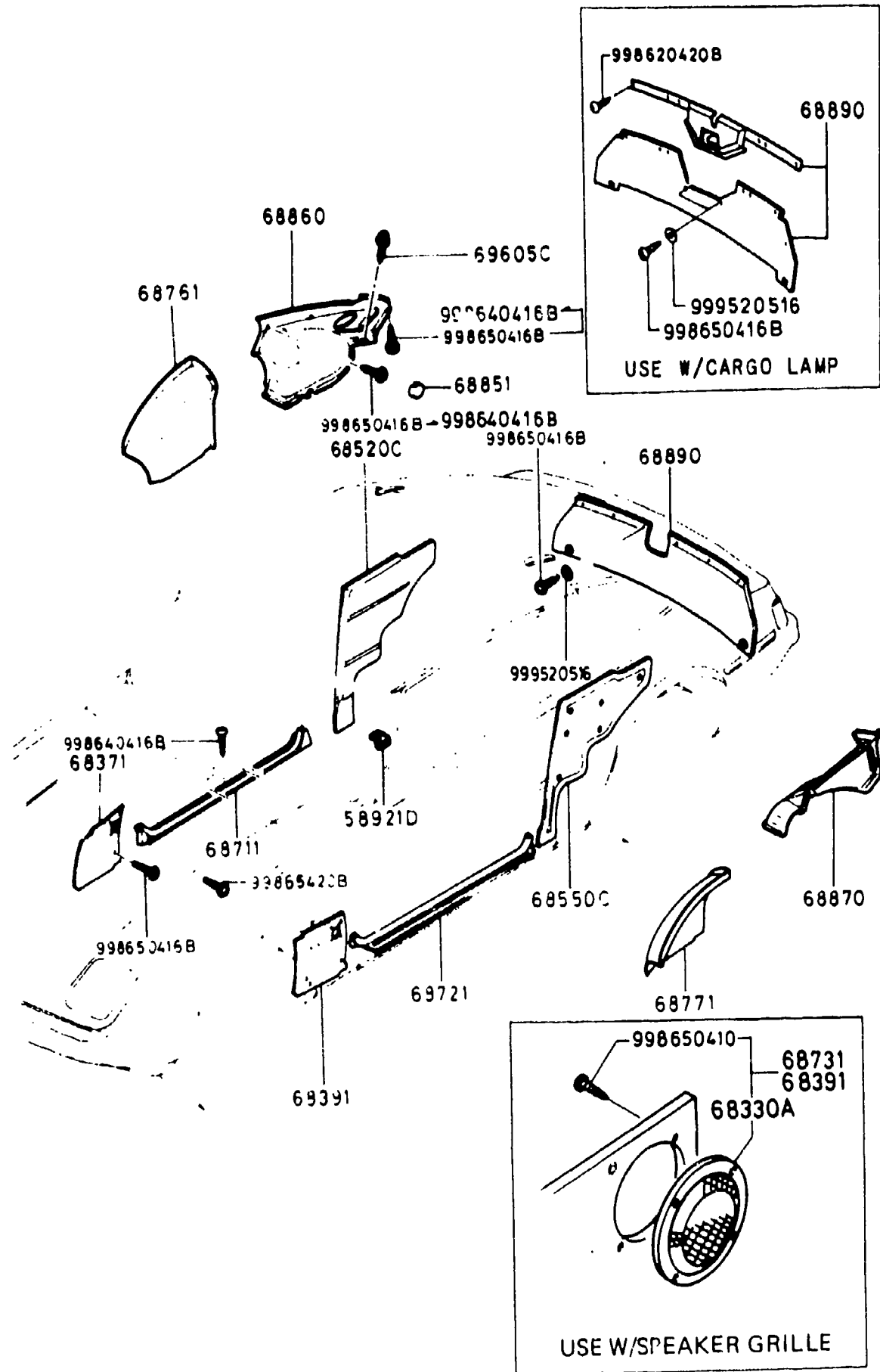

ITEM NO.	D-CODE	DESCRIPTION	PART NO.	QTY	MODEL/DESCRIPTION	REMARKS
68 890 (CONT'D)		RED	11			
		TAN	29			
		BROWN	70			
			8341-68-890C	1	(USE W/O CARGO LAMP)	
		BLACK	00			
		RED	11			
69 605C		TAN	29			
		BROWN	70			
		HOOK, TRIM	8871-68-855	2		

6860A-1 FLOOR MATS & PADS

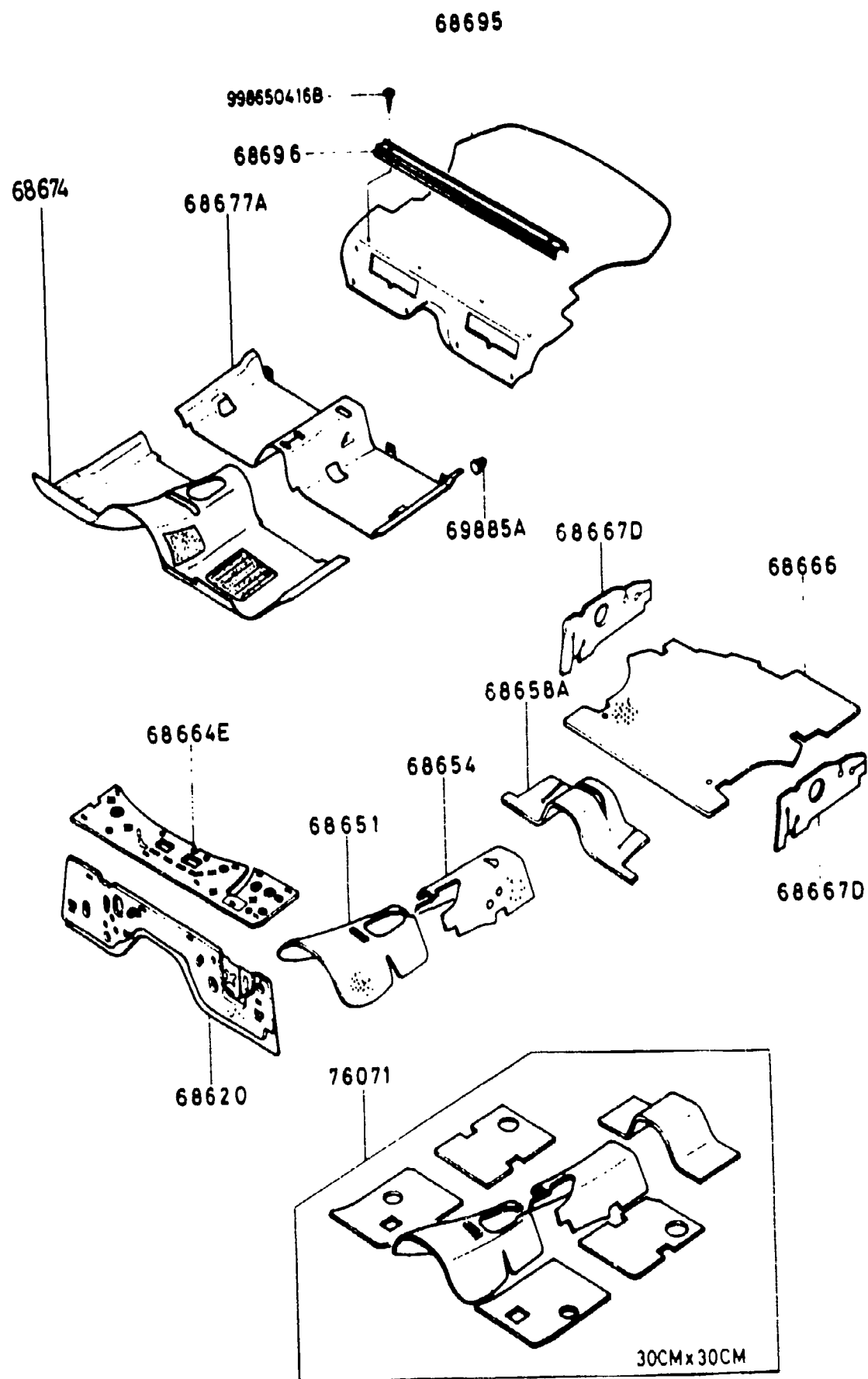

ITEM NO.	D-CODE	DESCRIPTION	PART NO.	QTY	MODEL/DESCRIPTION	REMARKS
	68 620	INSULATOR, DASHBOARD	FA01-68-620B	1		
	68 651	PAD (C), FLOOR-FRONT	FA01-68-651A	1		
	68 654	PAD (C), FLOOR-REAR	1480-68-654A	1		
	68 658A	PAD, STORAGE BOX	FA01-68-658	1		
	68 664E	INSULATOR, DASH-UPPER	8871-68-664B	1		
	68 666	PAD (L), FLOOR-TRUNK	FA01-68-666	1		
	68 667D	PAD, TRUNK SIDE	8871-68-667A	2		
	68 674	MAT, FRONT FLOOR	FA01-68-671B	1		
		BLACK	00			
		RED	11			
		BROWN	70			
	68 677A	MAT, REAR FLOOR	FA02-68-677	1	(USE SMALL TYPE REAR CONSOLE)	FB331 ..500001-600000
		BLACK	00			
		RED	11			
		BROWN	70			
			FA02-68-677A	1	(USE SMALL TYPE REAR CONSOLE)	
		BLACK	00			
		RED	11			
		BROWN	70			
		TAN	72			
			FA01-68-677	1	(USE LARGE TYPE REAR CONSOLE)	FB331 ..500001-600000
		BLACK	00			
		RED	11			
		BROWN	70			
			FA03-68-677	1	(USE LARGE TYPE REAR CONSOLE)	
		BLACK	00			
		RED	11			
		BROWN	70			
		TAN	72			
	68 695	MAT, TRUNK ROOM	FA01-68-695C	1		
		RED	11			
		BLACK	77			
		BROWN	85			
	68 696	PLATE, MAT SET	8871-68-696B	1		
		OFF BLACK	65			

6860A-2 FLOOR MATS & PADS

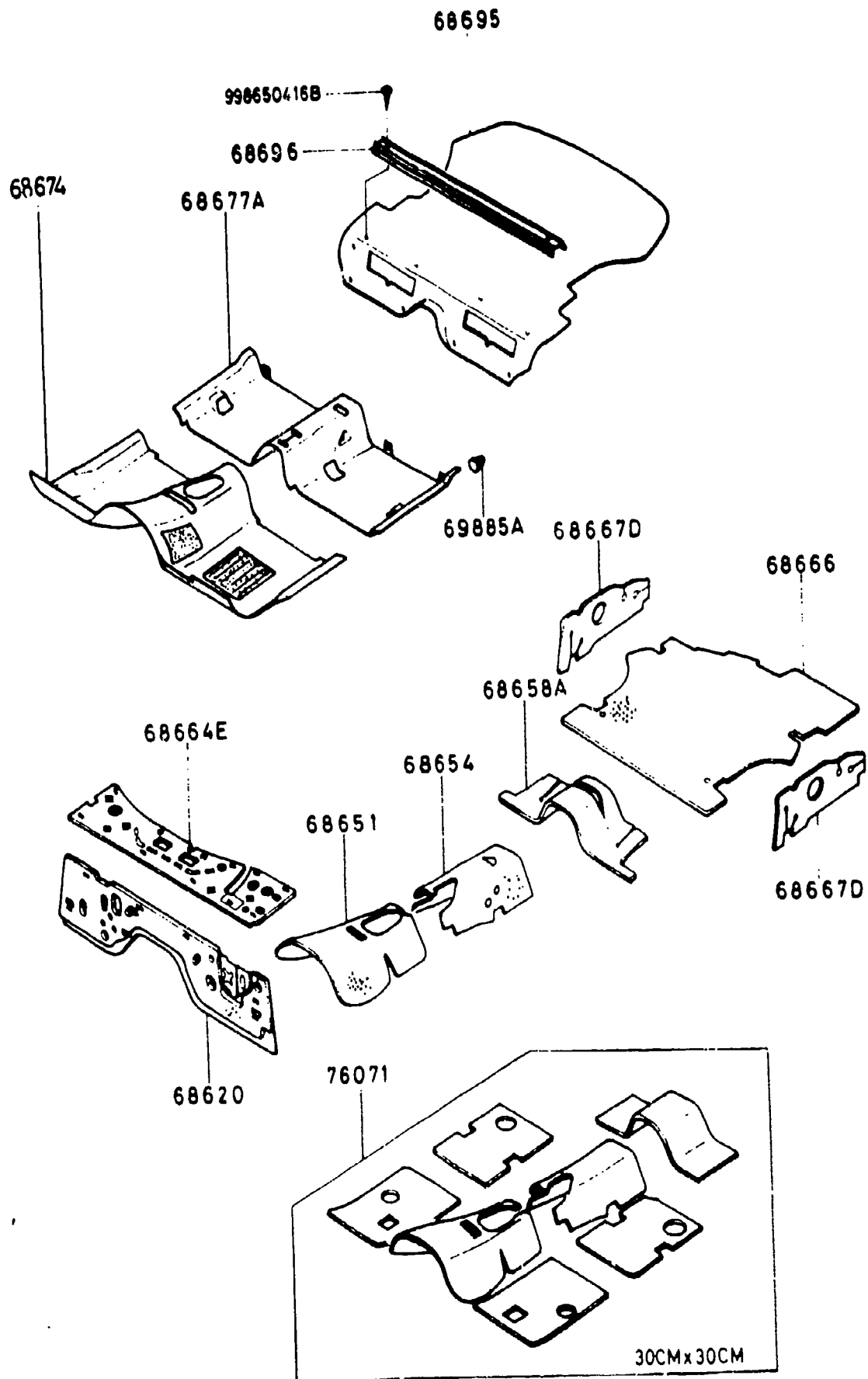

ITEM NO.	D-CODE	DESCRIPTION	PART NO.	QTY	MODEL/DESCRIPTION	REMARKS
	69 885A	FASTENER BLACK	0866-69-885A 00	7		
	76 071	SILENCER, FLOOR	0208-76-071	1	(30CM X 30CM)	

6870A-1 SERVICE TOOLS

ITEM NO.	D-CODE	DESCRIPTION	PART NO.	QTY	MODEL/DESCRIPTION	REMARKS
	68 070	WRENCH, HUB NUT	0810-68-070E	1		
	68 660A	TOOL SET	3781-69-650	1		
	68 670	BAG, TOOL	8173-69-670	1		

68660A

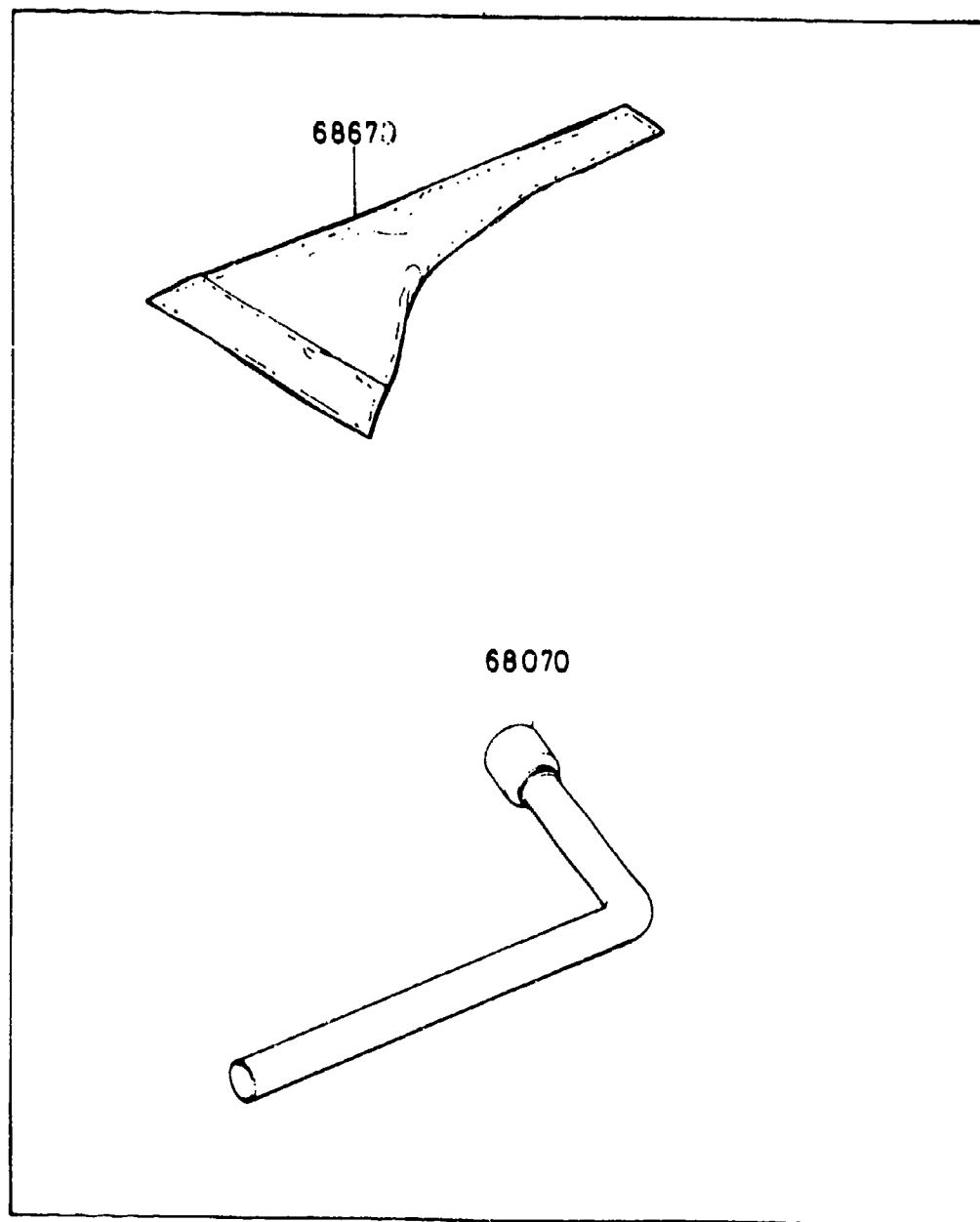

6900A-1 VISOR, ASSIST HANDLE & MIRRORS

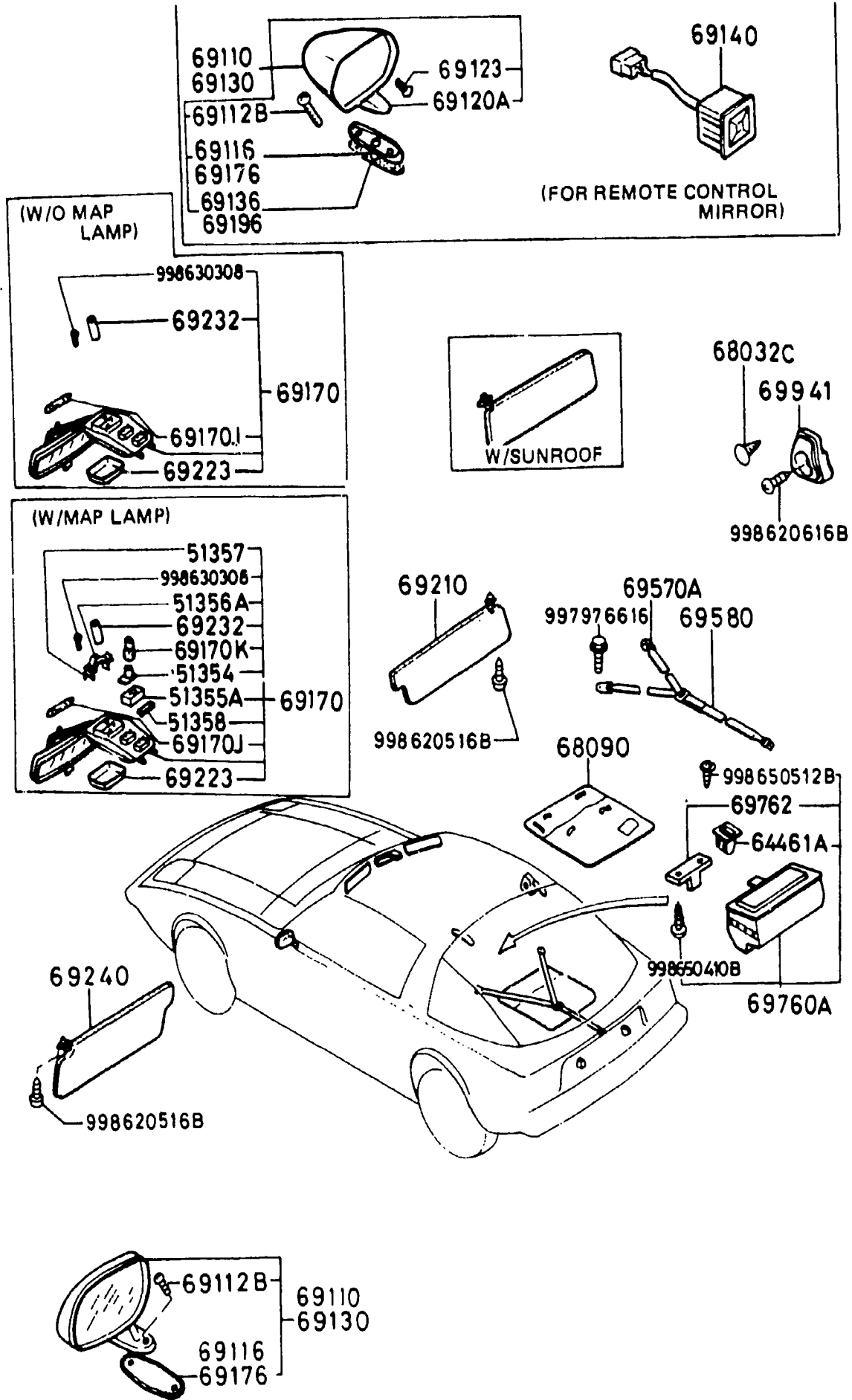

ITEM NO.	D-CODE	DESCRIPTION	PART NO.	QTY	MODEL/DESCRIPTION	REMARKS
	51 354	SOCKET & HOLDER	FA01-51-354	1	(FOR MAP LAMP) GS & GSL MODELS	
	51 355A	LAMP, SPOT	FA01-51-355A	1	(FOR MAP LAMP) GS & GSL MODELS	
	51 356A	PLATE	FA01-51-356	1	(FOR MAP LAMP) GS & GSL MODELS	
	51 357	BRACKET 'A'	FA01-51-357	1	(FOR MAP LAMP) GS & GSL MODELS	
	51 358	BRACKET 'B'	FA01-51-358	1	(FOR MAP LAMP) GS & GSL MODELS	
	64 461A	STRIKER, STORAGE BOX	1011-64-461A	2	'82 & '83 MODELS	FB331 ..629395-
	68 032C	FASTENER	FA24-68-032	1	(USE W/ COAT HANGER)	
		BLACK	00			
		RED	11			
		BROWN	70			
		TAN	71			FB331 ..600001-
	68 090	BAG, SUNROOF	8973-68-090C	1	SUNROOF	
	69 110	MIRROR (R), REAR VIEW	8341-69-110A	1	(REMOTE CONTROL TYPE) '81 MODEL GS & GSL MODELS	FB331 ..500001-503735
				1		FB331 ..503736-
			8871-69-110B	1	(MANUAL TYPE) S MODEL	
	69 112B	SCREW, MIRROR	8218-69-118	4	(USE W/ REM. CONTROL MIRROR) '83 MODEL GS & GSL MODELS	FB331 ..503736
			8341-69-178	4	(USE W/ REM. CONTROL MIRROR) GS & GSL MODELS	FB331 ..503736
			8871-69-178	4	(USE W/ MANUAL MIRROR) S MODEL	
	69 116	BASE (R), MIRROR	8341-69-131	1	(USE W/ REM. CONTROL MIRROR) GS & GSL MODELS	FB331 ..503736-
			8871-69-117A	1	(USE W/ MANUAL MIRROR) S MODEL	
	69 120A	STAY (R), MIRROR	8341-69-122	1	'83 MODEL	
		STAY (L), MIRROR	8341-69-182	1	'83 MODEL	
	69 123	SCREW, MIRROR	8341-69-123	4	'83 MODEL	
	69 130	MIRROR (L), REAR VIEW	8341-69-170A	1	(REMOTE CONTROL TYPE) '81 MODEL GS & GSL MODELS	FB331 ..500001-503735
				1		FB331 ..503736-

6900A-2 VISOR, ASSIST HANDLE & MIRRORS

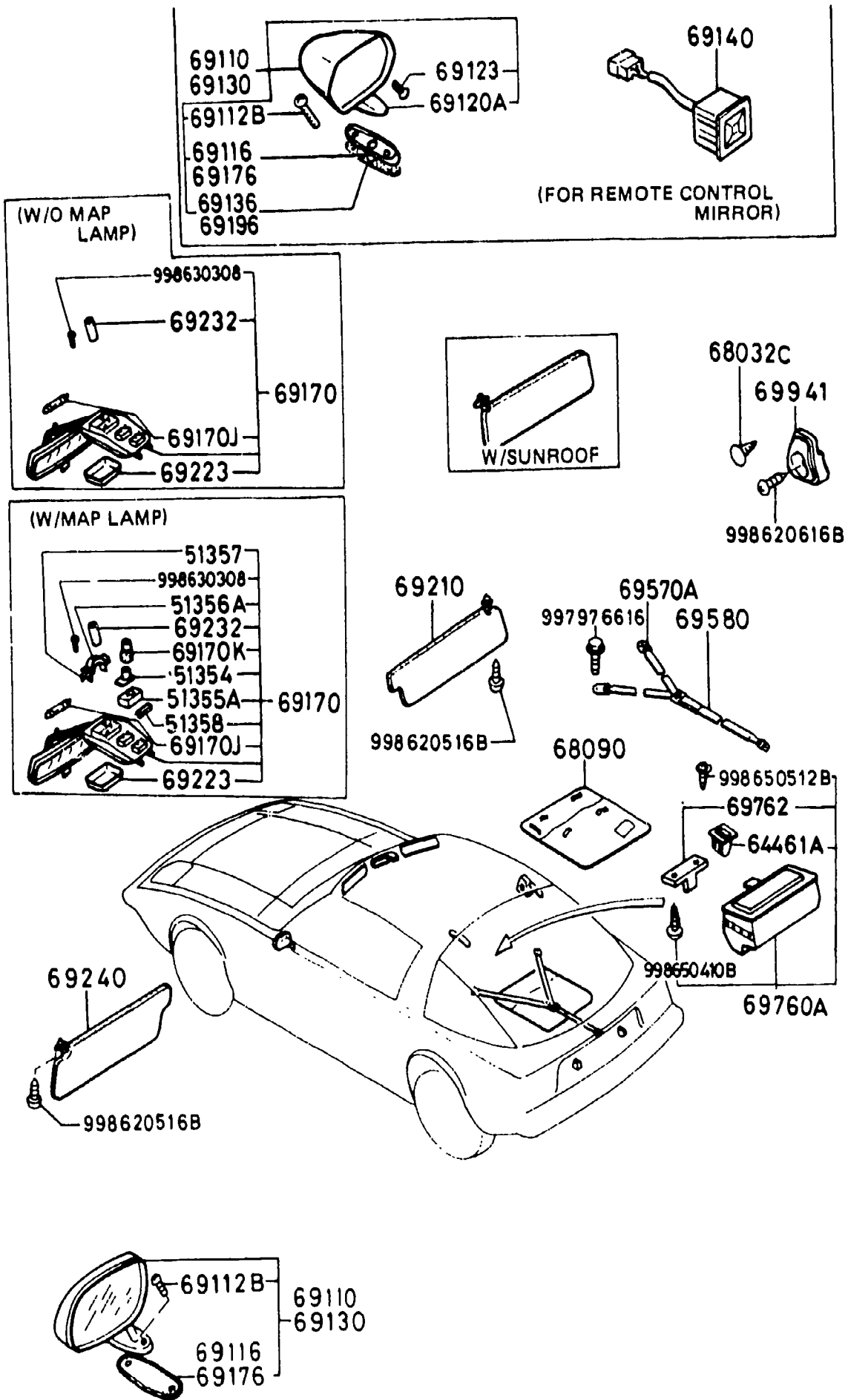

ITEM NO.	D-CODE	DESCRIPTION	PART NO.	QTY	MODEL/DESCRIPTION	REMARKS
69 130	(CONT'D)		8871-69-170B	1	(MANUAL TYPE)	
					S MODEL	
69 136		GASKET (R), MIRROR	8341-69-115	1	(USE W/ REM. CONTROL	FB331 ..503736-
					GS & GSL MODELS	
69 140		SWITCH, MIRROR	FA02-66-600A	1		
69 170		MIRROR, INTERIOR	FA01-69-220A	1	(W/ MAP LAMP)	
					GS & GSL MODELS	
			FA03-69-220A	1	(W/O MAP LAMP)	
					S MODEL	
69 170J		BULB	0000-11-3175	1	(A12V 10W)	
69 170K		BULB	0000-11-0194	1	(A12V 5W)	
69 176		BASE (L), MIRROR	8341-69-191	1	(USE W/ REM. CONTROL	FB331 ..503736-
					MIRROR)	
			8871-69-177	1	(USE W/ MANUAL MIRROR)	FB331 ..500001-507335
					'81 MODEL	
					S MODEL	
			< A > 8871-69-177A	1	(USE W/ MANUAL MIRROR)	FB331 ..507336-
					S MODEL	
69 196		GASKET (L), MIRROR	8341-69-116	1	(USE W/ REM. CONTROL	FB331 ..503736-
					MIRROR)	
					GS & GSL MIRRORS	
69 210		SUN VISOR (R)	8341-69-270	1		
		BLACK	02			
		RED	10			
		TAN	28			
		BROWN	70			
69 223		LENS, INTERIOR MIRROR	FA01-51-351A	1		
69 232		STOPPER, RUBBER	FA01-69-232	1		
69 240		SUN VISOR (L)	FA04-69-320	1	SUNROOF	
		BLACK	02			
		RED	10			
		TAN	28			
		BROWN	70			
			8341-69-320	1	NORM. ROOF	
		BLACK	02			
		RED	10			
		TAN	28			
		BROWN	70			
69 570A		STRAP 'A', CARGO ROOM	8341-69-570	1		
		BLACK	00			
		WINE	10			
		BROWN	20			

6900A-3 VISOR, ASSIST HANDLE & MIRRORS

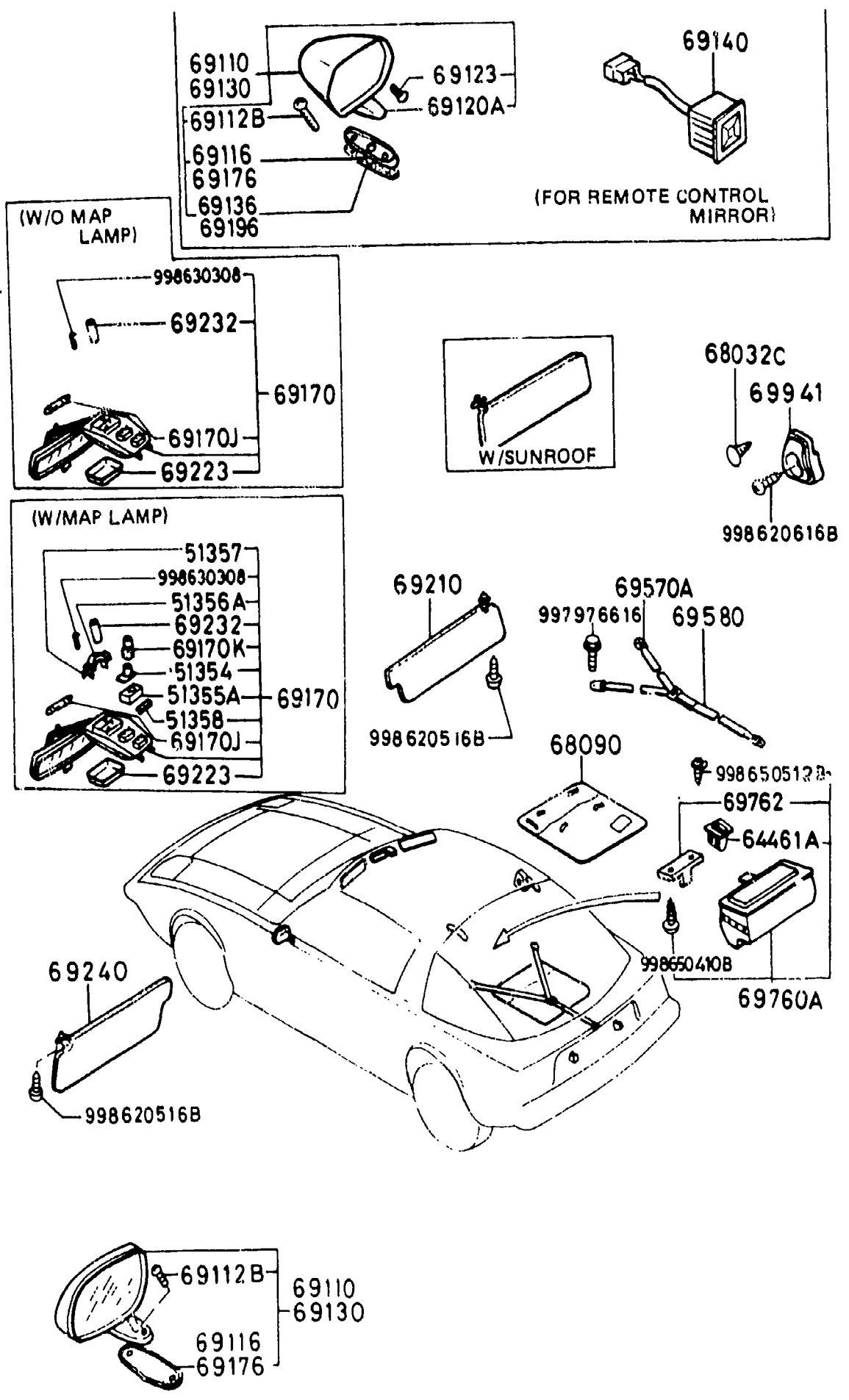

ITEM NO.	D-CODE	DESCRIPTION	PART NO.	QTY	MODEL/DESCRIPTION	REMARKS
	69 570A (CONT'D)	TAN	29			FB331 ..600001-
	69 580	STRAP 'B', CARGO ROOM	8341-69-580	1		
		BLACK	00			
		WINE	10			
		BROWN	20			
		TAN	29			FB331 ..600001-
	69 760A	BOX, STORAGE	FA01-69-760	2	'81 & '82 MODELS	
		BLACK	00			
		RED	11			
		TAN	29			FB331 ..600001-
		BROWN	70			
			FA42-69-760A	2	'83 MODEL	
		BLACK	00			
		RED	11			
		TAN	29			
		BROWN	70			
	69 762	PLATE, LOCK	FA42-69-762	2		
	69 941	HANGER, COAT	0376-69-941	1		
		BLACK	01			
			<AN> 0376-69-941B	1		
		BLACK	01			

6930A-1 CAUTION PLATES

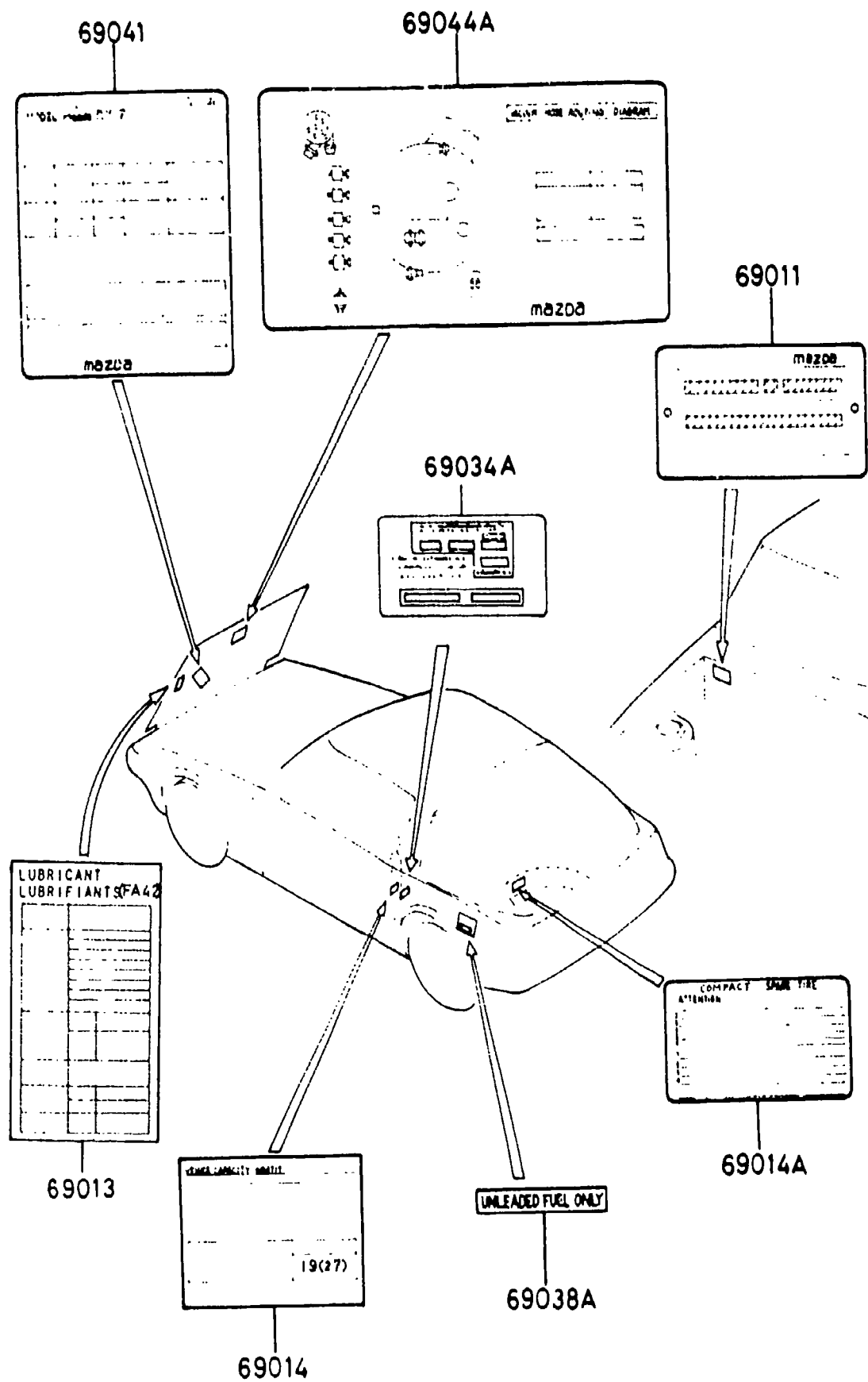

ITEM NO.	D-CODE	DESCRIPTION	PART NO.	QTY	MODEL/DESCRIPTION	REMARKS
	69 011	PLATE MODEL	8595-69-011B	1		
	69 013	LABEL, OIL	FA42-69-013	1	'83 MODEL	
	69 014	LABEL, TIRE	8871-69-014C	1	'81 & '82 MODELS	
			FA42-69-014B	1	'83 MODEL	
	69 014A	LABEL, TEMPORARY TIRE	FA02-69-073A	1		
	69 034A	LABEL, CAUTION-MVSS	8374-69-034A	1		
	69 038A	LABEL, GASOLINE	FA01-69-065	1		
		BLACK	00			
		WHITE	01			
	69 041	LABEL, EMISSION	N201-69-036	1	CAL. '81 MODEL	
			N203-69-036	1	FED. '81 MODEL	
			N223-69-036	1	CAL. '82 MODEL	
			N221-69-036	1	FED. '82 MODEL	
			N231-69-036	1	FED. '83 MODEL	
			N233-69-036	1	CAL.	
	69 044A	LABEL, VACUUM DIAPHRAGM	N201-69-044A	1	'81 MODEL	
			N221-69-044	1	'82 MODEL	
			N231-69-044A	1	'83 MODEL	

ALPHABETICAL INDEX

ALPHABETICAL INDEX

PART NAME	D-CODE	SECTION	LOCATION	PART NAME	D-CODE	SECTION	LOCATION	PART NAME	D-CODE	SECTION	LOCATION
* * * A * * *											
ABSORBER (L), SHOCK		5000A -1	2 - D 3		19704	1950A -1	1 - H 6	BODY (R), FRONT DOOR	58010	5800A -1	2 - J 6
ABSORBER (R), SHOCK	50100	5000A -1	2 - D 3		26610	2610A -1	1 - F 8	BODY, OIL FILTER	14310	1400A -1	1 - I 4
ABSORBER, SHOCK-REAR	50200	5010A -1	2 - F 3		41920	4140A -1	1 - K 9	BOLT		6132AB-2	2 - M 7
ACCESSORY KIT		6142A -1	2 - E 8	BAND	76511	6115A -1	2 - H 7			6142AC-1	2 - G 8
		6142AC-1	2 - G 8		76514	6115A -1	2 - H 7			6142A -1	2 - E 8
		6142AB-1	2 - F 8		66946	6680A -2	2 - K 9			6142A -1	2 - E 8
ACTUATOR	13290	1380A -1	1 - F 4	BAND (L), TANK FIXTURE	42420	4200A -1	1 - M 9		10845	1040A -1	1 - E 3
	13290	1380AA-1	1 - H 4	BAND (R), TANK FIXTURE	42410	4200A -1	1 - M 9		18912	6600A -1	2 - N 8
ACTUATOR, A.C.C.	66310	6640A -1	2 - I 9	BAND, BRAKE	19360	1930A -1	1 - E 6		19064	1910A -1	1 - N 5
ADAPTER	19025	1910A -1	1 - N 5	BAND, HOSE	76423	6110A -1	2 - G 7		19216	1910A -1	1 - N 5
ADAPTER (L), MOUNTING		3300A -1	1 - C 9	BASE (L), MIRROR	69176	6900A -2	2 - J 11		19255	1910A -1	1 - N 5
ADAPTER (R), MOUNTING	33260	3300A -1	1 - C 9	BASE (R), MIRROR	69116	6900A -1	2 - I 11		19338	1920A -1	1 - C 6
ADAPTER KIT		6142AC-1	2 - G 8	BATTERY	18520	1850A -1	1 - M 5		19397	1920A -1	1 - C 6
		6142A -1	2 - E 8	BEAM, SEALED	84851	5100A -1	2 - J 3		19397	1940A -1	1 - G 6
		6142AB-1	2 - F 8	BEARING		6142A -1	2 - E 8		19398	1920A -1	1 - C 6
ADJUSTER (L)		2610A -1	1 - F 8			6142AB-1	2 - F 8		19706	1950A -1	1 - H 6
ADJUSTER (R)	26630	2610A -1	1 - F 8			6142AC-1	2 - G 8		19737	1920A -1	1 - C 6
ADJUSTER NO. 1	88102	5700AA-1	2 - C 6		24722	1840A -1	1 - K 5		19838	1950A -1	1 - H 6
	88102	5700A -1	2 - H 5		24743	1840A -2	1 - L 5		19838	1950A -1	1 - H 6
ADJUSTER NO. 2	88103	5700AA-1	2 - C 5		26151	2600A -1	1 - E 8		24729	1840A -1	1 - K 5
	88103	5700A -1	2 - H 5		27305	2700A -2	1 - I 8		25123	2500AA-1	1 - D 8
ADJUSTER NO. 3	88152	5700A -3	2 - J 5	BEARING, BALL	32182	3210A -1	1 - M 8		25123	2500A -1	1 - C 8
	88152	5700AA-4	2 - F 6		15010	1500A -1	1 - K 4		26132	2610AA-1	1 - G 8
ADJUSTER NO. 4	88153	5700A -3	2 - J 5		15010	1500AA-1	1 - M 4		26132	2610A -1	1 - F 8
	88153	5700AA-4	2 - F 6		17201	171CA -1	1 - E 5		28111	2800A -1	1 - J 8
ALTERNATOR	18300	1830A -1	1 - J 5		17204	1710A -1	1 - E 5		28113	2800A -1	1 - J 8
AMPLIFIER, MAIN	66920	6680A -2	2 - K 9		17221	1710A -1	1 - E 5		32186	5010A -1	2 - F 3
AMPLIFIER, POWER-FRONT	66920	6680A -2	2 - K 9		17297	1710A -1	1 - E 5		32429	3210A -1	1 - M 8
AMPLIFIER, POWER-REAR	66920	6680A -2	2 - K 9		17301	1710A -1	1 - E 5		39055	3900A -1	1 - H 9
ANTENNA	66930	6680A -2	2 - K 9		17303	1710A -1	1 - E 5		50015	5000A -1	2 - D 3
ARM & BALL JOINT (L)		3400A -1	1 - D 9		24503	1830A -1	1 - J 5		50015	5010A -1	2 - F 3
ARM & BALL JOINT (R)	49310	3400A -1	1 - D 9	BEARING, FRONT WHEEL	24514	1830A -1	1 - J 5	BOLT & KEY KIT, HUB	37160	3700A -1	1 - F 9
ARM (L), KNUCKLE		3400A -1	1 - D 9		33047	3300A -1	1 - C 9	BOLT SACK KIT		6142A -1	2 - E 8
ARM (R), KNUCKLE		3400A -1	1 - D 9	BEARING, MAIN	33075	3300A -1	1 - C 9			6142AC-1	2 - G 8
ARM (L), REGULATOR		5830A -1	2 - K 6	BEARING, NEEDLE	10502	1030A -1	1 - D 3			6142AB-1	2 - F 8
ARM (R), REGULATOR	32301	3400A -1	1 - D 9		11403	1100A -1	1 - G 3	BOLT SET	24731	1840A -2	1 - L 5
ARM, ADJUSTING-FRONT	58560	5830A -1	2 - K 6		11505	1100A -1	1 - G 3	BOLT, AIR CLEANER	13201	1320A -1	1 - K 3
		6142AB-1	2 - F 8		17274	1710A -1	1 - E 5	BOLT, ANCHOR END	19341	1920A -1	1 - C 6
		6142AC-1	2 - G 8		19621	1930A -1	1 - E 6	BOLT, ARM	34313	3410A -1	1 - E 9
ARM, ADJUSTING-REAR		6142AB-1	2 - F 8		19622	1930A -1	1 - E 6	BOLT, BAND HOLDER	66124	6611A -1	2 - D 9
		6142AC-1	2 - G 8		19623	1930A -1	1 - E 6	BOLT, CLAMP	70985	1850A -1	1 - M 5
ARM, IDLER	32320	3230A -1	1 - N 8	BEARING, PINION-FRONT	19624	1930A -1	1 - E 6	BOLT, COMPRESSOR		6132AC-2	2 - D 8
ARM, PITMAN	32220	3210A -1	1 - M 8		27141	2700A -1	1 - H 8	BOLT, CONNECTOR	19930	1910A -1	2 - N 5
ARM, WIPER	67321	6730A -1	2 - G 10	BEARING, PINION-REAR	27141	2700A -1	1 - H 8		43694	4340A -1	1 - C 10
	67421	6750A -1	2 - I 10	BEARING, ROLLER	17205	1710A -1	1 - E 5	BOLT, CONTROL VALVE	19831	1920A -2	1 - D 6
ARMATURE	24720	1840A -1	1 - K 5	BEARING, ROTOR	11111	1110A -1	1 - H 3		19832	1920A -2	1 - D 6
ATTACHMENT-PAD	49290	2610AA-1	1 - G 8	BELT 'A' (L), FRONT SEAT	57920	5790A -2	2 - I 6		19833	1920A -2	1 - D 6
	49290	3300A -1	1 - C 9	BELT 'A' (R), FRONT SEAT	57900	5790A -1	2 - H 6	BOLT, GEAR HOUSING	32186	3210A -1	1 - M 8
AUTO CRUISE CONTROL SET	99063	6640A -1	2 - I 9	BELT 'B' (R), FRONT SEAT	57630	5790A -1	2 - H 6	BOLT, HAND BRAKE LEVER	44053	4400A -1	1 - F 10
* * * B * * *				BELT (L), FRONT SEAT	57920	5790A -1	2 - H 6	BOLT, HEX		6132AB-1	2 - L 7
				BELT (R), FRONT SEAT	57900	5790A -1	2 - H 6			6132A -1	2 - J 7
BACK (L), FRONT SEAT	88180	5700AA-5	2 - G 6	BELT, DRIVE		6142A -1	2 - E 8			6132AC-1	2 - C 8
	88180	5700A -4	2 - K 5			6142AC-1	2 - G 8			6142AC-1	2 - G 8
BACK (R), FRONT SEAT	88130	5700AA-3	2 - E 6	BEZEL (L), LAMP	50760	5005A -1	2 - E 3	BOLT, HINGE	51431	5103A -1	2 - K 3
	88130	5700A -2	2 - I 5	BEZEL (R), LAMP	50740	5005A -1	2 - E 3	BOLT, JOINT	49652	4340A -1	1 - C 10
BAG, SUNROOF	68090	6900A -1	2 - I 11	BI-METAL SET	23502	1360A -2	1 - D 4	BOLT, LOCK	14117	1400A -1	1 - I 4
BAG, TOOL	68670	6870A -1	2 - H 11	BLADE	76631	6730A -1	2 - G 10		14117	1400AA-1	1 - J 4
BALANCER, STICK	66920	6680A -2	2 - K 9		76631	6750A -1	2 - I 10	BOLT, OIL PAN	19837	1920A -2	1 - D 6
BALL	19245	1910A -1	1 - N 5	BLADE, WIPER	67330	6730A -1	2 - G 10	BOLT, PULLEY	11376	1100A -1	1 - G 3
BALL NUT, WORM	32130	3210A -1	1 - M 8		67330	6750A -1	2 - I 10	BOLT, REAMER	13137	1380A -1	1 - F 4
BALL, STEEL	11411	1100A -1	1 - G 3	BLOCK, FUSE	66730	6700A -1	2 - M 9		13137	1380AA-1	1 - H 4
	13781	1360A -1	1 - C 4	BLOCK, MOUNTING	34380	3400A -1	1 - D 9		16432	1600A -1	1 - C 5
	17341	1710A -2	1 - F 5	BLOWER	61140	6100A -1	2 - F 7		27235	2700A -1	1 - H 8
	17411	1720A -1	1 - G 5	BODY (L), FRONT DOOR		5800A -1	2 - J 6	BOLT, SET	14125	1400AA-1	1 - J 4
	19341	1940A -1	1 - G 6								

ALPHABETICAL INDEX

PART NAME	D-CODE	SECTION	LOCATION	PART NAME	D-CODE	SECTION	LOCATION	PART NAME	D-CODE	SECTION	LOCATION
BOLT, SET	14125	1400A -1	1 - I 4	BRACKET, CENTER-REAR	64430	5570A -2	2 - F 5	BULB & SOCKET	75115	5540A -1	2 - N 4
	60436	0900A -1	2 - C 3	BRACKET, CHECK VALVE	42750	4200A -1	1 - M 9		75115	5540A -1	2 - N 4
BOLT, STABILIZER	34157	3410A -1	1 - E 9	BRACKET, COMPRESSOR	15920	1580A -1	1 - N 4		76552	6100A -1	2 - F 7
BOLT, STOPPER	32315	3400A -1	1 - D 9	BRACKET, CONTROL LINK	28120	2810A -1	1 - K 8		55240	5570A -1	2 - E 5
BOLT, TENSION	10451	1040A -1	1 - E 3	BRACKET, CONTROL UNIT	18820	6600A -1	2 - N 8		55280	5500A -1	2 - L 4
	10452	1040A -1	1 - E 3	BRACKET, CUT VALVE	45131	4500A -1	1 - G 10		66254	6610A -1	2 - C 9
BOLT, TENSION ROD	34134	3410A -1	1 - E 9	BRACKET, DAMPER	62631	6230A -1	2 - K 8		34111	3400A -1	1 - D 9
BOLT, WHEEL SET	33165	3700A -1	1 - F 9	BRACKET, DECK	56560	5360A -1	2 - J 4		50031	5000A -1	2 - D 3
BOOT	46081	4600A -1	1 - H 10	BRACKET, ENGINE MOUNTING	39020	3900A -1	1 - H 9		50221	5010A -1	2 - F 3
	51938	5103A -1	2 - K 3	BRACKET, FIXING	32420	3210A -1	1 - M 8		22333	1700A -1	1 - D 5
	64331	5570A -1	2 - E 5	BRACKET, FRONT	24550	1830A -1	1 - J 5		32071	3210A -1	1 - M 8
BOOT KIT	49250	510AA -1	1 - G 8		24710	1840A -1	1 - K 5		32329	3230A -1	1 - N 8
	49250	3300A -1	1 - C 9	BRACKET, FUEL PUMP	45121	4500A -1	1 - G 10		32412	3210A -1	1 - M 8
BOOT SET	26681	2410A -1	1 - F 8	BRACKET, HOSE CLAMP		6132AC -1	2 - C 8		34156	3410A -1	1 - E 9
BOOT, CHANGE	64331	5570A -1	2 - E 5	BRACKET, IGNITION	18810	1800A -1	1 - H 5		41644	4160A -1	1 - L 9
BOOT, DUST	17475	1720A -1	1 - G 5	BRACKET, IGNITION COIL	18190	1800A -1	1 - H 5		46085	4600A -1	1 - H 10
BOSS, STEERING WHEEL	32980	3200A -1	1 - L 8	BRACKET, JACK	53045	5360A -1	2 - J 4		46684	4600A -1	1 - H 10
BOSS, WATER PUMP PULLEY	15117	1500A -1	1 - K 4	BRACKET, LEVER	46110	4600A -1	1 - H 10		57633	5790A -1	2 - H 6
	15117	1500AA -1	1 - M 4	BRACKET, MASTER CYLINDER	43070	4300A -1	1 - N 9		58411	5830A -1	2 - K 6
BOX (L), TORQUE	54391	5360A -1	2 - J 4	BRACKET, MOUNTING-COMPRESSOR		6142A -1	2 - E 8		67717	6630A -1	2 - G 9
BOX (R), TORQUE	53391	5360A -1	2 - J 4	BRACKET, MOUNTING-RECV/DRIER		6132A -1	2 - J 7		76123	6120A -1	2 - I 7
BOX, A.C.C.	66320	6640A -1	2 - I 9	BRACKET, MOUNTING-RECEIVER/DRIER		6132AB -1	2 - L 7		76123	6110A -1	2 - G 7
BOX, COIN	64345	5570A -1	2 - E 5	BRACKET, MOUNTING-THERMOSTAT		6152A -1	2 - H 8		76129	6110A -1	2 - G 7
BOX, GEAR	76610	6760A -1	2 - J 10	BRACKET, OIL HOSE	14740	1500A -1	1 - K 4		76146	6115A -1	2 - H 7
	76613	6740A -1	2 - H 10	BRACKET, OIL PIPE	14744	1400AA -1	1 - J 4		76164	6115A -1	2 - H 7
BOX, LAMP	55225	5500A -1	2 - L 4	BRACKET, OPENER	42490	4200A -1	1 - M 9		76415	6115A -1	2 - H 7
BOX, STORAGE	69760	6900A -3	2 - K 11	BRACKET, RADIATOR	50715	5005A -1	2 - E 3		76427	6110A -1	2 - G 7
BRACKET	13081	1350A -1	1 - M 3	BRACKET, REAR	24560	1830A -1	1 - J 5		88105	5700AA -2	2 - D 6
	13241	1380AA -1	1 - H 4		24740	1840A -2	1 - L 5		88105	5700A -1	2 - H 5
	13241	1380A -1	1 - F 4	BRACKET, RECEIVER-DRIER		6132AC -2	2 - D 8		17481	1720A -1	1 - G 5
	13757	1380AA -1	1 - H 4	BRACKET, RESISTOR	18590	1800A -1	1 - H 5		34460	3400A -1	1 - D 9
	13757	1380A -1	1 - F 4	BRACKET, STABILIZER SUPPORT	28155	2810A -1	1 - K 8		41023	4300A -1	1 - N 9
	19960	1910A -1	1 - N 5	BRACKET, STARTER	18401	1800A -1	1 - H 5		46684	4600A -1	1 - H 10
	40070	4000A -1	1 - I 9	BRACKET, SUB TANK	15251	1500A -2	1 - L 4		49686	4340A -1	1 - C 10
	40081	4000A -1	1 - I 9		15251	1500AA -1	1 - M 4		49686	4140A -1	1 - K 9
	40640	4000A -2	1 - J 9	BRACKET, TANK	13515	1350A -1	1 - M 3		51432	5103A -1	2 - K 3
	55970	6630A -1	2 - G 9	BRACKET, THERMOSTAT MOUNTING		6152AC -1	2 - J 8		76605	6730A -1	2 - G 10
	76504	6115A -1	2 - H 7			6152AB -1	2 - I 8		76607	6730A -1	2 - G 10
BRACKET 'A'	51357	6900A -1	2 - I 11	BRACKET, WASHER TANK	67521	6720A -1	2 - F 10		76607	6750A -1	2 - I 10
BRACKET 'B'	51358	6900A -1	2 - I 11	BRACKET, WATT LINK	28180	2800A -1	1 - J 8		76623	6750A -1	2 - I 10
BRACKET 'U'		5103A -1	2 - K 3	BRACKET, WIPER MOTOR	76624	6750A -1	2 - I 10		76691	4600A -1	1 - H 10
BRACKET (L), CONDENSER		6132A -1	2 - J 7	BRAKE (L), CALIPER		3300A -1	1 - C 9		76604	6730A -1	2 - G 10
		6132AB -1	2 - L 7	BRAKE (L), DISC		2610AA -1	1 - G 8		76606	6750A -1	2 - I 10
BRACKET (L), FENDER	54290	5310A -1	2 - G 4	BRAKE (R), CALIPER	33980	3300A -1	1 - C 9		43022	4300A -1	1 - N 9
BRACKET (L), INSTRUMENTATION	71260	5310A -2	2 - H 4	BRAKE (R), DISC	26980	2610AA -1	1 - G 8		28102	2810A -1	1 - K 8
BRACKET (L), TENSION ROD		3410A -1	1 - E 9	BREATHING	26060	2600A -1	1 - E 8		28775	2800A -1	1 - J 8
BRACKET (R)	51932	5103A -1	2 - K 3	BREATHING, AIR	17530	1700A -1	1 - D 5		28775	2810A -1	1 - K 8
BRACKET (R), CONDENSER		6132AB -1	2 - L 7		19344	1920A -1	1 - C 6		34153	3410A -1	1 - E 9
		6132A -1	2 - J 7	BRUSH	24522	1830A -1	1 - J 5		76434	6110A -1	2 - G 7
BRACKET (R), FENDER	53290	5310A -1	2 - G 4		76617	6760A -1	2 - J 10		46032	4600A -1	1 - H 10
BRACKET (R), INSTRUMENTATION	70260	5310A -1	2 - G 4	BRUSH, YOKE	24753	1840A -2	1 - L 5		44033	4400A -1	1 - F 10
BRACKET (R), TENSION ROD	34850	3410A -1	1 - E 9		51060	5105A -1	2 - L 3				
BRACKET SET	23377	1360A -1	1 - C 4	BULB	51120	5105A -1	2 - L 3				
BRACKET, ABSORBER	13390	1310A -1	1 - J 3		51150	5110A -1	2 - M 3				
BRACKET, ACTUATOR	13241	1380A -1	1 - F 4		51150	5110A -1	2 - M 3				
	13241	1380AA -1	1 - H 4		51270	5120A -1	2 - N 3				
BRACKET, ALTERNATOR	18371	1800A -1	1 - H 5		51440	5125A -1	2 - C 4				
BRACKET, ANTENNA NO. 1	66535	6680A -1	2 - J 9		51550	5120A -1	2 - N 3				
BRACKET, ANTENNA NO. 2	66536	6680A -1	2 - J 9		55270	5500A -1	2 - L 4				
BRACKET, CANISTER	13960	1320A -1	1 - K 3		55240	5570A -1	2 - E 5				
BRACKET, CASE-BOTTOM		6152A -1	2 - H 8		55280	5500A -1	2 - L 4				
		6152AB -1	2 - I 8		55280	5500A -1	2 - L 4				
BRACKET, CASE-TOP		6152AB -1	2 - I 8		55890	5560A -1	2 - C 5				
		6152A -1	2 - H 8		69170	6900A -2	2 - J 11				
BRACKET, CENTER	24706	1840A -1	1 - K 5		69170	6900A -2	2 - J 11				
	64360	5570A -1	2 - E 5								

*** C ***

ALPHABETICAL INDEX

PART NAME	D-CODE	SECTION	LOCATION	PART NAME	D-CODE	SECTION	LOCATION	PART NAME	D-CODE	SECTION	LOCATION
CAP	42307	1380A -1	1 - F 4		19310	1920A -1	1 - C 6		45903	1910A -1	1 - N 5
	42307	1380AA -1	1 - H 4	CASING, REAR AXLE	26010	2600A -1	1 - E 8		45903	4500A -1	1 - G10
	44034	4400A -1	1 - F10	CASING, STOPPER	39045	3900A -1	1 - H 9		50506	5030A -1	2 - G 3
CAP & ROTOR		1820A -1	1 - I 5	CEILING, TOP	68030	6800A -1	2 - K10		51402	1320A -1	1 - K 3
CAP (L), PULL HANDLE		5840A -2	2 - D 7		68080	6800A -1	2 - K10		58316	6230A -1	2 - K 8
CAP (R), PULL HANDLE	69374	5840A -2	2 - D 7	CHAIN, OIL PUMP	14151	1400AA -1	1 - J 4		66365	6640A -1	2 - I 9
CAP SET, RESERVE TANK	41552	4140A -1	1 - K 9		14151	1400A -1	1 - I 4		66944	6730A -1	2 - G10
	43552	4340A -1	1 - C10	CHAMBER SET, DIAPHRAGM		1359A -1	1 - N 3		67031	6704A -1	2 - E10
CAP TANK	87992	6720A -1	2 - F10		23271	1360A -1	1 - C 4		67515	6720A -1	2 - F10
CAP, BLEEDER	33693	4140A -1	1 - K 9	CHAMBER, THROTTLE	23311	1360A -1	1 - C 4		76419	6110A -1	2 - G 7
CAP, BLEEDER SCREW	33693	2610A -1	1 - F 8	CHANNEL, GLASS	58605	5800A -1	2 - J 6		76419	6120A -1	2 - I 7
	33693	2610AA -1	1 - G 8	CHIME	55811	5540A -1	2 - N 4		76434	6120A -1	2 - I 7
CAP, CENTER	37190	3700A -1	1 - F 9	CHOKE SET, RETURN	23534	1360A -2	1 - D 4		76435	6110A -1	2 - G 7
CAP, DAMPER	34019	3400A -1	1 - D 9	CHOKE SET, SEMI AUTOMATIC	23300	1360A -2	1 - D 4		76435	6120A -1	2 - I 7
CAP, FASTENER	58922	5840A -1	2 - C 7	CIRCUIT	67561	6630A -1	2 - G 9	CLIP, AIR HOSE	13726	1371A -1	1 - E 4
CAP, FILLER	42250	4200A -1	1 - M 9	CLAMP	24304	1820A -1	1 - I 5		14745	1500A -1	1 - K 4
CAP, FRONT CONSOLE	64901	5570A -2	2 - F 5		24305	1820A -1	1 - I 5	CLIP, CABLE	44439	4400A -1	1 - F10
CAP, GARNISH	60701	5560A -1	2 - C 5		76173	6110A -1	2 - G 7		67290	1850A -1	1 - M 5
CAP, HORN	32800	3200A -1	1 - L 8	CLAMP NO. 1, BULB		6152AC -1	2 - J 8		67293	1850A -1	1 - M 5
CAP, HUB	33071	3300A -1	1 - C 9			6152AB -1	2 - I 8	CLIP, CEILING	70335	6800A -3	2 - M10
CAP, IDLE LIMITER	23436	1359A -1	1 - N 3			6152A -1	2 - H 8	CLIP, DRAIN HOSE	13305	5340A -1	2 - I 4
CAP, IDLE SWITCH	13205	1320A -1	1 - K 3	CLAMP NO. 10, HOSE		6132A -1	2 - J 7	CLIP, ENGINE HARNESS	18994	1800A -1	1 - H 5
CAP, OIL FILLER	10250	1030A -1	1 - D 3	CLAMP NO. 6, HOSE		6132A -1	2 - J 7	CLIP, EVAPORATOR COIL PIPE		6152A -1	2 - H 8
CAP, PULL HANDLE	69872	5840A -2	2 - D 7			6132AC -1	2 - C 8			6152AB -1	2 - I 8
CAP, RADIATOR	15205	1500A -1	1 - K 4			6132AB -1	2 - L 7			6152AC -1	2 - J 8
	15205	1500AA -1	1 - M 4	CLAMP NO. 8, HOSE		6132A -1	2 - J 7	CLIP, FLEXIBLE HOSE	43635	4360AA -1	1 - E10
CAP, REGULATOR HANDLE	58585	5830A -2	2 - L 6			6132AB -1	2 - L 7		43635	4360A -1	1 - D10
CAP, RUBBER	33693	3300A -1	1 - C 9	CLAMP, BATTERY	56030	1850A -1	1 - M 5		43635	4140A -1	1 - K 9
CAP, SCHRADER VALVE		6142AC -1	2 - G 8	CLAMP, CABLE	76407	6115A -1	2 - H 7		43635	4360A -1	1 - D10
CAP, SEAL	66371	6750A -1	2 - I10		76412	6115A -1	2 - H 7		43635	4360AA -1	1 - E10
	76604	6730A -1	2 - G10	CLAMP, DRAIN HOSE		6152AB -1	2 - I 8	CLIP, HEATER HOSE	15545	6100A -1	2 - F 7
CAP, SPRING	17474	1720A -1	1 - G 5			6152AC -1	2 - J 8	CLIP, HOSE	43635	4360AA -1	1 - E10
	17491	1720A -1	1 - G 5			6152A -1	2 - H 8		43635	4360A -1	1 - D10
CAP, SUB TANK	15355	1500AA -1	1 - M 4	CLAMP, FUEL FILTER	13481	1320A -1	1 - K 3	CLIP, OIL PIPE	14745	1400AA -1	1 - J 4
	15355	1500A -2	1 - L 4	CLAMP, HOSE		6132A -1	2 - J 7	CLIP, OIL TUBE	14296	1400AA -1	1 - J 4
CAP, TANK	76672	6750A -1	2 - I10			6132AC -1	2 - C 8		14296	1400A -1	1 - I 4
CAP, TRUNK SIDE TRIM	63851	6840A -2	2 - D11			6132AB -1	2 - L 7	CLIP, PIPE	45901	4500A -1	1 - G10
CAP, WHEEL	37170	3700A -1	1 - F 9			6132A -1	2 - J 7		45903	4500A -1	1 - G10
CARBURETOR	13600	1359A -1	1 - N 3			1500AA -1	1 - M 4		45903	4500A -1	1 - G10
CARRIER, BATTERY	53260	1850A -1	1 - M 5	CLAMP, MAIN JET PLUG	15189	1360A -1	1 - C 4	CLIP, RETAINER		6152AC -1	2 - J 8
CARRIER, DIFFERENTIAL	27150	2700A -1	1 - H 8	CLAMP, RELEASE WIRE	52302	5230A -1	2 - F 4			6152AB -1	2 - I 8
CARRIER, FRONT	19540	1930A -1	1 - E 6	CLAMP, SPARE TIRE	56210	3700A -2	1 - G 9			6152A -1	2 - H 8
CARRIER, REAR	19570	1930A -1	1 - E 6	CLAMP, WIRE HARNESS		6132A -2	2 - K 7	CLIP, WIRE	58559	6704A -1	2 - E10
CARTRIDGE, OIL FILTER	23802	1400A -1	1 - I 4			6132AB -1	2 - L 7	CLOCK, AUTO	55710	5500A -2	2 - M 4
	23802	1400AA -1	1 - J 4	CLAMP/BACKET, HOSE		6132AB -1	2 - L 7	CLUTCH		6142AC -1	2 - G 8
CASE	27230	2700A -1	1 - H 8	CLAMPS, RECEIVER/DRIER		6132A -1	2 - J 7			6142AB -1	2 - F 8
	76425	6120A -1	2 - I 7	CLEANER, AIR	13320	1330A -1	1 - L 3			6142A -1	2 - E 8
CASE, BOTTOM		6152AB -1	2 - I 8	CLIP	13445	1320A -1	1 - K 3	CLUTCH, FRONT	19460	1930A -1	1 - E 6
		6152AC -1	2 - J 8		13447	1320A -1	1 - K 3	CLUTCH, ONE-WAY	19595	1940A -1	1 - G 6
		6152A -1	2 - H 8		14662	1500AA -1	1 - M 4	CLUTCH, OVER RUNNING	24722	1840A -1	1 - K 5
CASE, CHANGE CONTROL	17470	1720A -1	1 - G 5		14662	1500A -1	1 - K 4	CLUTCH, REAR	19510	1930A -1	1 - E 6
CASE, CONTROL UNIT	67571	6630A -1	2 - G 9		18762	5540A -1	2 - N 4	COIL, EVAPORATOR		6152AC -1	2 - J 8
CASE, FAN	76423	6120A -1	2 - I 7		10861	1800A -1	1 - H 5			6152AB -1	2 - I 8
CASE, HEATER	76401	6110A -1	2 - G 7		18863	1500A -2	1 - L 4			6152A -1	2 - H 8
	76406	6110A -1	2 - G 7		19915	1910A -1	1 - N 5	COIL, FIELD		6142A -1	2 - E 8
CASE, LAMP	55213	5500A -1	2 - L 4		19916	1920A -2	1 - D 6			6142AB -1	2 - F 8
CASE, MAIN FUSE	66760	6700A -1	2 - M 9		19989	1910A -1	1 - N 5			6142AC -1	2 - G 8
CASE, METER	55441	5540A -1	2 - N 4		32107	3210A -1	1 - M 8	COIL, IGNITION	18100	1800A -1	1 - H 5
CASE, SWITCH PANEL	64411	5570A -2	2 - F 5		41666	6640A -1	2 - I 9	COLLAR	76472	6120A -1	2 - I 7
CASE, TOP		6152AC -1	2 - J 8		44173	4400A -1	1 - F10	COLLAR, BEARING	26152	2600A -1	1 - E 8
		6152A -1	2 - H 8		44189	4400A -1	1 - F10	COLLAR, CLUTCH RELEASE	16510	1600A -1	1 - C 5
		6152AB -1	2 - I 8		44436	4400A -1	1 - F10	COMPENSATOR	23693	1330A -1	1 - L 3
CASE, TRANSITION		6152AB -1	2 - I 8		44471	4400A -1	1 - F10	COMPRESSOR		6142AC -1	2 - G 8
		6152A -1	2 - H 8		45903	4360AA -1	1 - E10			6142AB -1	2 - F 8
		6152AC -1	2 - J 8		45903	4360A -1	1 - D10			6142A -1	2 - E 8
CASE, TRANSMISSION	17100	1700A -1	1 - D 5								

ALPHABETICAL INDEX

PART NAME	D-CODE	SECTION	LOCATION	PART NAME	D-CODE	SECTION	LOCATION	PART NAME	D-CODE	SECTION	LOCATION
COMPRESSOR/CLUTCH		6142AC-1	2 - G 8		16214	1600A -1	1 - C 5	DIAPHRAGM, VACUUM	19823	1920A -1	1 - C 6
		6142A -1	2 - E 8		32411	3210A -1	1 - M 8	DIODE	67242	6680A -2	2 - K 9
		6142AB-1	2 - F 8		34015	3400A -1	1 - D 9	DIPSTICK	10450	1030A -1	1 - D 3
CONDENSER		6132A -1	2 - J 7	COVER, DUST (L)	26140	2610AA-1	1 - G 8		19880	1920A -2	1 - D 6
		6132AB-1	2 - L 7	COVER, DUST (R)	26130	2610AA-1	1 - G 8	DISC, CLUTCH	16460	1600A -1	1 - C 5
	24334	1820A -1	1 - I 5	COVER, FRONT	10600	1040A -1	1 - E 3	DISTRIBUTOR	18200	1820A -1	1 - I 5
	24581	1830A -1	1 - J 5		16220	1600A -1	1 - C 5	DISTRIBUTOR, OIL	19650	1940A -1	1 - G 6
CONDENSER ASSEMBLY		6132AC-1	2 - C 8	COVER, HEATER	61145	6110A -1	2 - G 7	DOWEL, TUBULAR	10111	1030A -1	1 - D 3
CONDENSER SACK KIT		6132AB-1	2 - L 7	COVER, HINGE	88107	5700AA-2	2 - D 6		10204	1040A -1	1 - E 3
CONNECTOR	13945	6640A -1	2 - I 9		88107	5700A -1	2 - H 5	DRIVE & DIFFERENTIAL	27100	2700A -1	1 - H 8
	14730	1500A -1	1 - K 4	COVER, HOLE	55225	5500A -1	2 - L 4	DRUM, BRAKE	26251	2610A -1	1 - F 8
CONNECTOR SET, FUEL	23409	1360A -2	1 - D 4		56051	5370A -1	2 - K 4	DRUM, CLUTCH	19470	1930A -1	1 - E 6
CONNECTOR, HOSE	10320	1040A -1	1 - E 3		56051	5370A -1	2 - K 4	DRUM, CONNECTING	19590	1940A -1	1 - G 6
CONNECTOR, SHORT	67985	6701A -1	2 - N 9	COVER, INNER HANDLE	58303	5830A -1	2 - K 6		19591	1940A -1	1 - G 6
CONNECTOR, WIRE		6152AB-1	2 - I 8	COVER, LAMP	60223	5500A -2	2 - M 4	DRUM, REAR CLUTCH	19511	1930A -1	1 - E 6
		6152A -1	2 - H 8	COVER, MOTOR	76421	6120A -1	2 - I 7	DUCT	61150	6100A -1	2 - F 7
CONSOLE, FRONT	64310	5570A -1	2 - E 5	COVER, SERVICE HOLE	50310	5010A -1	2 - F 3	DUCT (L), SIDE DEMISTER	60182	5580A -1	2 - G 5
CONSOLE, REAR	64410	5570A -2	2 - F 5		56061	5370A -1	2 - K 4		61184	5580A -1	2 - G 5
CONTACT	24496	1820A -1	1 - I 5		56231	5370A -1	2 - K 4	DUCT (R)	64761	5580A -1	2 - G 5
CONTACT, HORN	60267	6611A -1	2 - D 9		56639	5370A -1	2 - K 4	DUCT (R), SIDE DEMISTER	60181	5580A -1	2 - G 5
CONTROL UNIT	18940	6600A -1	2 - N 8	COVER, SERVO	19392	1920A -1	1 - C 6		61183	5580A -1	2 - G 5
CONTROL, HEATER	61190	6100A -1	2 - F 7	COVER, SET	33049	3300A -1	1 - C 9	DUCT NO. 1 (L)	64771	5580A -1	2 - G 5
CONVERTER, CATALYTIC	20500	4000A -1	1 - I 9	COVER, SIDE	19028	1910A -1	1 - N 5	DUCT NO. 2 (L)	64772	5580A -1	2 - G 5
CONVERTER, MONOLITH	40400	4000A -1	1 - I 9	COVER, SWITCH HOLE	55225	5570A -1	2 - E 5	DUCT NO. 3 (L)	64773	5580A -1	2 - G 5
CONVERTER, TORQUE	19100	1910A -1	1 - N 5	COVER, THERMOSTAT	15172	1500AA-1	1 - M 4	DUCT, CENTER	64750	5580A -1	2 - G 5
COOLER, OIL	14700	1500A -1	1 - K 4		15172	1500A -1	1 - K 4	DUCT, HOT AIR	13390	1310A -1	1 - J 3
	14700	1400AA-1	1 - J 4	COVER, TOP	19029	1910A -1	1 - N 5	DUM 'A' (L)	50526	5030A -1	2 - G 3
CORD CLIP ASSEMBLY, HIGH TENSION		6132AB-1	2 - L 7	COVER, UNDER	19027	1910A -1	1 - N 5	DUM 'A' (R)	50516	5030A -1	2 - G 3
		6132AC-1	2 - C 8		56111	5370A -1	2 - K 4	DUM 'B' (L)	50527	5030A -1	2 - G 3
		6132A -1	2 - J 7	COVER, WATER PUMP	15130	1500AA-1	1 - M 4	DUM 'B' (R)	50517	5030A -1	2 - G 3
CORD, DIN	66910	6680A -1	2 - J 9		15130	1500A -1	1 - K 4	*** E ***			
CORD, LOUD SPEAKER	66975	6680A -2	2 - K 9	COVER, WHEEL CORE	32049	3200A -1	1 - L 8	ELBOW, PLASTIC		6152AB-1	2 - I 8
CORD, REAR DEFOGGER	67051	6700A -1	2 - M 9	COVER, WIPER ARM	76641	6730A -1	2 - G 10			6152A -1	2 - H 8
	67051	6700A -1	2 - M 9	COVER, WIPER MOTOR	67435	6750A -1	2 - I 10			6152AC-1	2 - J 8
CORD, SHORT	66251	6610A -1	2 - C 9	COVER, WIPER, ARM	76641	6750A -1	2 - I 10	ELEMENT, AIR CLEANER	23603	1330A -1	1 - L 3
	66970	6680A -2	2 - K 9	COWLING, RADIATOR	15210	1500A -1	1 - K 4	EMBLEM	32811	3200A -1	1 - L 8
CORE, HEATER	76405	6110A -1	2 - G 7		15210	1500AA-1	1 - M 4		37192	3700A -1	1 - F 9
COUPLING SET	24340	1820A -1	1 - I 5	CUSHION	34136	3410A -1	1 - E 9	END, CONTROL ROD	17461	1720A -1	1 - G 5
COVER	17490	1700A -1	1 - D 5		56785	5230A -1	2 - F 4	END, SHIFT	17432	1720A -1	1 - G 5
	19240	1910A -1	1 - N 5	CUSHION (L), FRONT SEAT	88160	5700A -3	2 - J 5	END, SHIFT ROD (1ST & 2ND)	17410	1720A -1	1 - G 5
	23673	1330A -1	1 - L 3	CUSHION (L), FRT. SEAT	88160	5700AA-4	2 - F 6	END, SHIFT ROD (3RD & 4TH)	17422	1720A -1	1 - G 5
	24366	1820A -1	1 - I 5	CUSHION (R), FRONT SEAT	88110	5700A -1	2 - H 5	ENGINE BLOCK, SHORT	23800	1000A -1	1 - C 3
	40551	4000A -1	1 - I 9		88110	5700AA-2	2 - D 6	EQUALIZER, GRAPHIC	66920	6680A -2	2 - K 9
	66732	6700A -1	2 - M 9	CUSHION, DOOR	58906	5830A -2	2 - L 6	ESCUTCHEON	58375	5830A -1	2 - K 6
	76609	6730A -1	2 - G 10	CYLINDER (L), WHEEL		2610A -1	1 - F 8	EVAPORATOR ASSEMBLY		6152AB-1	2 - I 8
COVER (L), BRAKE		5570A -1	2 - E 5	CYLINDER (R), WHEEL	26610	2610A -1	1 - F 8			6152A -1	2 - H 8
COVER (L), COLUMN	60231	5500A -2	2 - M 4	CYLINDER, CLUTCH MASTER	41990	4140A -1	1 - K 9	EVAPORATOR SACK KIT		6152AC-1	2 - J 8
COVER (L), KNUCKLE	88166	5700AA-4	2 - F 6	CYLINDER, CLUTCH RELEASE	41920	4140A -1	1 - K 9	EVAPORATOR SCREW KIT		6152AB-1	2 - I 8
	88166	5700A -3	2 - J 5	CYLINDER, TANDEM MASTER	43990	4340A -1	1 - C 10			6152A -1	2 - H 8
COVER (R), BRAKE	64221	5570A -1	2 - E 5	*** D ***				EXTRACTOR (L)		5180A -1	2 - E 4
COVER (R), COLUMN	60221	5500A -2	2 - M 4	DAM, FRONT W/SHIELD GLASS	63902	6300A -1	2 - L 8	EXTRACTOR (R)	51911	5180A -1	2 - E 4
COVER (R), KNUCKLE	88116	5700AA-3	2 - E 6	DAM, SIDE WINDOW	63942	6300A -1	2 - L 8	*** F ***			
	88116	5700A -2	2 - I 5	DAMPER	34910	3400A -1	1 - D 9	FAN & FAN DRIVE	15250	1500A -1	1 - K 4
COVER KIT, END	32150	3210A -1	1 - M 8	DAMPER SET, REAR	28700	2800A -1	1 - J 8		15250	1500AA-1	1 - M 4
COVER KIT, SIDE	32170	3210A -1	1 - M 8	DAMPER, SUB SET-FRONT	49790	3400A -1	1 - D 9	FAN DRIVE	15210	1500A -1	1 - K 4
COVER LATCH	62882	6330A -1	2 - M 8	DASH POT	24190	1360A -2	1 - D 4		15210	1500AA-1	1 - M 4
COVER SET	24741	1840A -2	1 - L 5	DECK (L), FLOOR	56540	5360A -1	2 - J 4	FAN, COOLING	15140	1500AA-1	1 - M 4
COVER SET, LEVER GAUGE	23340	1360A -1	1 - C 4	DECK (R), FLOOR	56510	5360A -1	2 - J 4		15140	1500A -1	1 - K 4
COVER, BEARING	17325	1700A -1	1 - D 5	DECK, TAPE-CASSETTE	66860	6680A -1	2 - J 9	FASTENER	50036	5000A -1	2 - D 3
	76509	6115A -1	2 - H 7	DEFLECTOR	62801	6330A -1	2 - M 8		50036	5010A -1	2 - F 3
	76512	6115A -1	2 - H 7	DIAPHRAGM, CARBURETOR	23322	1360A -1	1 - C 4		50037	5000A -1	2 - D 3
COVER, BLIND	17486	1720A -1	1 - G 5	DIAPHRAGM, SHUTTER VALVE	13130	1380AA-1	1 - H 4		50242	5180A -1	2 - E 4
COVER, CLUTCH	16410	1600A -1	1 - C 5		13130	1380A -1	1 - F 4				
COVER, CONTROL UNIT	67566	6630A -1	2 - G 9								
COVER, DUST	10305	1040A -1	1 - E 3								
	10351	1040A -1	1 - E 3								

ALPHABETICAL INDEX

PART NAME	D-CODE	SECTION	LOCATION	PART NAME	D-CODE	SECTION	LOCATION	PART NAME	D-CODE	SECTION	LOCATION
FASTENER	58762	5800A -1	2 - J 6	*** G ***				GASKET, OIL STRAINER	14171	1400AA-1	1 - J 4
	58921	5840A -1	2 - C 7	GARNISH (L)	60781	5560A -2	2 - D 5		14171	1400A -1	1 - I 4
	58921	6840A -1	2 - C 11	GARNISH (L), CTR. TRIM	68240	6800A -2	2 - L 10	GASKET, REGULATOR HANDLE	58552	5830A -1	2 - K 6
	68032	5310A -1	2 - G 4	GARNISH (L), SIDE WINDOW	51891	6300A -1	2 - L 8	GASKET, SHUTTER VALVE	13139	1380A -1	1 - F 4
	68032	6900A -1	2 - I 11	GARNISH (L), TOP-SIDE	68060	6800A -1	2 - K 10		13139	1380AA-1	1 - H 4
	68865	6800A -3	2 - M 10	GARNISH (R)	60771	5560A -1	2 - C 5	GASKET, SPRING CAP	17475	1720A -1	1 - G 5
	68965	6800A -3	2 - M 10	GARNISH (R), CTR. TRIM	68220	6800A -2	2 - L 10	GASKET, WATER PUMP	15116	1500AA-1	1 - M 4
	69885	6860A -2	2 - G 11	GARNISH (R), SIDE WINDOW	51881	6300A -1	2 - L 8		15116	1500A -1	1 - K 4
FASTENER, FRT. P/TRIM	68172	6800A -2	2 - L 10	GARNISH (R), TOP-SIDE	68050	6800A -1	2 - K 10	GASKET, WHEEL CYLINDER	26615	2610A -1	1 - F 8
	68172	6800A -2	2 - L 10	GARNISH, TOP-FRONT	68021	6800A -1	2 - K 10	GAUGE UNIT, OIL PRESSURE	14820	6600A -1	2 - N 8
FASTENER, KEY CYLINDER	58961	0900A -1	2 - C 3	GARNISH, UPPER	60720	5560A -1	2 - C 5	GAUGE, FUEL TANK	60960	4200A -1	1 - M 9
FASTENER, PROTECTOR	69885	5370A -1	2 - K 4	GASKET	13135	1380A -1	1 - F 4	GAUGE, GASKET	66773	4200A -1	1 - M 9
FASTENER, W/SHIELD MLDG.-FRONT	50608	5030A -1	2 - G 3		13135	1380AA-1	1 - H 4	GEAR	24746	1840A -2	1 - L 5
FEEDER-ANTENNA	66935	6680A -2	2 - K 9		14823	1500A -1	1 - K 4	GEAR SET	24744	1840A -2	1 - L 5
FIBER, OPTICAL	55251	5500A -1	2 - L 4		15081	1500A -1	1 - K 4	GEAR SET, FINAL	27110	2700A -1	1 - H 8
FILLER, REAR BUMPER	50311	5010A -1	2 - F 3		15081	1500AA-1	1 - M 4	GEAR, 1ST	17271	1710A -1	1 - E 5
FILTER, FUEL	13470	1320A -1	1 - K 3		15082	1500A -1	1 - K 4	GEAR, 2ND	17250	1710A -1	1 - E 5
FINISHER, REAR	50850	5180A -1	2 - E 4		15082	1500AA-1	1 - M 4	GEAR, 3RD	17230	1710A -1	1 - E 5
FLANGE	19580	1940A -1	1 - G 6		15173	1500AA-1	1 - M 4	GEAR, COUNTER	17308	1710A -2	1 - F 5
	76453	6120A -1	2 - I 7		15173	1500A -1	1 - K 4	GEAR, COUNTER REVERSE	17302	1710A -1	1 - E 5
FLANGE, COMPANION	27020	2700A -1	1 - H 8		15611	6600A -1	2 - N 8	GEAR, COUNTER SHAFT	17301	1710A -1	1 - E 5
FLANGE, DRIVE	19581	1940A -1	1 - G 6		20771	1380AA-1	1 - H 4	GEAR, DIFFERENTIAL SIDE	27251	2700A -1	1 - H 8
FLATWASHER		6132AB-1	2 - L 7		20771	1380A -1	1 - F 4	GEAR, DRIVE	11531	1100A -1	1 - G 3
		6132AB-1	2 - L 7		23303	1360A -1	1 - C 4		17341	1710A -2	1 - F 5
		6132AC-1	2 - C 8		23481	1360A -2	1 - D 4	GEAR, DRIVE-OIL PUMP	11551	1100A -1	1 - G 3
		6132A -1	2 - J 7		40325	4000A -1	1 - I 9	GEAR, DRIVEN	14625	1400A -1	1 - I 4
		6142A -1	2 - E 8		40356	4000A -1	1 - I 9		14625	1400AA-1	1 - J 4
		6142AC-1	2 - G 8		40375	4000A -1	1 - I 9		17441	1700A -1	1 - D 5
		6142AB-1	2 - F 8		40668	4000A -2	1 - J 9		19441	1920A -1	1 - C 6
		6152AB-1	2 - I 8		43443	4340A -1	1 - C 10	GEAR, MAIN DRIVE	17201	1710A -1	1 - E 5
		6152AC-1	2 - J 8		76455	6120A -1	2 - I 7	GEAR, OVER TOP	17611	1710A -2	1 - F 5
		6152A -1	2 - H 8		76464	6120A -1	2 - I 7	GEAR, REVERSE	17281	1710A -1	1 - E 5
FLOAT	43542	4340A -1	1 - C 10	GASKET (L), MIRROR	69196	6900A -2	2 - J 11	GEAR, REVERSE IDLE	17310	1710A -2	1 - F 5
FLOAT SET, FRONT	23328	1360A -1	1 - C 4	GASKET (L), RR. COMB.		5110A -1	2 - M 3	GEAR, RING	11502	1100A -1	1 - G 3
FLOAT SET, REAR	23329	1360A -1	1 - C 4	GASKET (R), MIRROR	69136	6900A -2	2 - J 11	GEAR, SHELL & SUN	19550	1930A -1	1 - E 6
FLYWHEEL	11500	1100A -1	1 - G 3	GASKET (R), RR. COMB.	51164	5110A -1	2 - M 3	GEAR, SPEEDOMETER	17341	1940A -1	1 - G 6
FORK, BRAKE	43140	4300A -1	1 - N 9	GASKET KIT		6142A -1	2 - E 8	GEAR, STATIONARY-FRONT	10500	1030A -1	1 - D 3
FORK, CLUTCH	41140	4300A -1	1 - N 9			6142AB-1	2 - F 8	GEAR, STATIONARY-REAR	10550	1030A -1	1 - D 3
FORK, CLUTCH RELEASE	16520	1600A -1	1 - C 5			6142AC-1	2 - G 8	GEAR, STEERING	32110	3210A -1	1 - M 8
FORK, SHIFT	17406	1720A -1	1 - G 5	GASKET SET	23510	1359A -1	1 - N 3	GEAR, SUN	19560	1930A -1	1 - E 6
FORK, SHIFT (1ST & 2ND)	17402	1720A -1	1 - G 5		23680	1330A -1	1 - L 3	GENERATOR, A.C.C.	66330	6640A -1	2 - I 9
FORK, SHIFT (3RD & 4TH)	17404	1720A -1	1 - G 5	GASKET SET, ENGINE	10271	1000A -1	1 - C 3	GLASS (L), DOOR		5800A -1	2 - J 6
FRAME	76602	6730A -1	2 - G 10	GASKET, AIR CONTROL VALVE	13724	1371A -1	1 - E 4	GLASS (L), SIDE WINDOW	63951	6300A -1	2 - L 3
FRAME & PAD (L), BACK	88190	5700A -4	2 - K 5	GASKET, CAP	42462	4200A -1	1 - M 9	GLASS (R), DOOR	58500	5800A -1	2 - J 6
	88190	5700AA-5	2 - G 6	GASKET, DRAIN PLUG	10405	1040A -1	1 - E 3	GLASS (R), SIDE WINDOW	63941	6300A -1	2 - L 9
FRAME & PAD (L), CUSHION	88170	5700AA-4	2 - F 6		42045	4200A -1	1 - M 9	GLASS, REAR WINDOW	63931	6300A -1	2 - L 8
	88170	5700A -4	2 - K 5	GASKET, EXHAUST MANIFOLD	13462	1310A -1	1 - J 3	GLASS, WINDSHIELD	63901	6300A -1	2 - L 8
FRAME & PAD (R), BACK	88140	5700A -3	2 - J 5	GASKET, EXHAUST PIPE	20920	1310A -1	1 - J 3	GOVERNOR	19660	1940A -1	1 - G 6
	88140	5700AA-4	2 - F 6	GASKET, EXTENSION	19735	1920A -1	1 - C 6	GOVERNOR SET	24330	1820A -1	1 - I 5
FRAME & PAD (R), CUSHION	88120	5700A -2	2 - I 5	GASKET, FILLER PIPE	42241	4200A -1	1 - M 9	GREASE	49246	2610AA-1	1 - G 8
	88120	5700AA-3	2 - E 6	GASKET, FLANGE	23358	1360A -1	1 - C 4		49246	3300A -1	1 - C 9
FRAME (L), REAR SIDE	54810	5360A -1	2 - J 4	GASKET, FLOAT CHAMBER	23321	1360A -1	1 - C 4	GRILLE	60565	5560A -1	2 - C 5
FRAME (L), SIDE-FRONT	54300	5310A -1	2 - G 4	GASKET, FRONT COMB.	51062	5105A -1	2 - L 3	GRILLE (L), EXTRACTOR		5180A -1	2 - E 4
FRAME (R), REAR SIDE	53810	5360A -1	2 - J 4	GASKET, FRONT COVER	10641	1040A -1	1 - E 3	GRILLE (R), EXTRACTOR	51901	5180A -1	2 - E 4
FRAME (R), SIDE-FRONT	53300	5310A -1	2 - G 4		16225	1600A -1	1 - C 5	GRILLE, COWL	50791	5180A -1	2 - E 4
FRAME, INSTRUMENT PANEL	60410	5560A -1	2 - C 5	GASKET, HOLE COVER	50292	5010A -1	2 - F 3	GRILLE, RADIATOR	50711	5005A -1	2 - E 3
FRONT PLATE & RECEIVER		6142A -1	2 - E 8	GASKET, INTAKE MANIFOLD	13111	1300A -1	1 - I 3	GRILLE, SPEAKER	66980	6680A -2	2 - K 9
FRONT PLATE & ROTOR		6142AC-1	2 - G 8	GASKET, KEY CYLINDER	58962	0900A -1	2 - C 3		68330	6840A -1	2 - C 11
		6142AB-1	2 - F 8	GASKET, LICENSE LAMP	51274	5120A -1	2 - N 3	GROMMET		6132AC-1	2 - C 8
FUNNEL	40560	4000A -1	1 - I 9	GASKET, METERING OIL	14611	1400A -1	1 - I 4			6132A -1	2 - J 7
FUSE (10A)	66495	6700A -1	2 - M 9		14611	1400AA-1	1 - J 4			6132AB-1	2 - L 7
FUSE (15A)	66496	6700A -1	2 - M 9	GASKET, OIL CAP	10252	1030A -1	1 - D 3			6152AB-1	2 - I 8
FUSE (20A)	66497	6700A -1	2 - M 9	GASKET, OIL PAN	10431	1040A -1	1 - E 3		28778	2800A -1	1 - J 8
FUSE (30A)	66497	6700A -1	2 - M 9		19835	1920A -2	1 - D 6		42348	4200A -1	1 - M 9
				GASKET, OIL PUMP	19215	1910A -1	1 - N 5		42452	4200A -1	1 - M 9

ALPHABETICAL INDEX

PART NAME	D-CODE	SECTION	LOCATION	PART NAME	D-CODE	SECTION	LOCATION	PART NAME	D-CODE	SECTION	LOCATION
GROMMET	61479	6100A -1	2 - F 7	HINGE, HOOD	52410	5230A -1	2 - F 4	HOSE, DRAIN-REAR	53980	5340A -1	2 - I 4
	87846	6730A -1	2 - G 10	HOLDER	41360	4140A -1	1 - K 9	HOSE, EVAPORATION	13972	1320A -1	1 - K 3
GROMMET, CHOKE WIRE	60052	5500A -2	2 - M 4	HOLDER, BRUSH	76612	6740A -1	2 - H 10		13973	1320A -1	1 - K 3
GROMMET, DRAIN HOSE		6152A -1	2 - H 8	HOLDER SET, RETURN	23371	1360A -1	1 - C 4	HOSE, FILLER	42221	4200A -1	1 - M 9
GROMMET, SCREW	51029	5100A -1	2 - J 3	HOLDER, BAND	60265	6611A -1	2 - D 9	HOSE, FLEXIBLE	41380	4140A -1	1 - K 9
	51962	5180A -1	2 - E 4	HOLDER, BI-METAL	23501	1360A -2	1 - D 4		43980	4360AA-1	1 - E 10
	66771	6635A -1	2 - H 9	HOLDER, BRAKE PIPE VALVE	43750	4360AA-1	1 - E 10		43980	4360A -1	1 - D 10
	72502	5800A -1	2 - J 6		43750	4360A -1	1 - D 10	HOSE, FUEL	13270	1320A -1	1 - K 3
GROMMET, WIRE HARNESS		6152A -1	2 - H 8	HOLDER, BRUSH	24750	1840A -2	1 - L 5		45125	4500A -1	1 - G 10
GUARD, PROTECTOR	40815	4000A -2	1 - J 9	HOLDER, CENTER LOUVER	64812	5580A -1	2 - G 5		45126	4500A -1	1 - G 10
GUIDE	40652	4000A -2	1 - J 9	HOLDER, HOOD STAY	52518	5230A -1	2 - F 4		45612	4500A -1	1 - G 10
	76421	6110A -1	2 - G 7	HOLDER, KEY CYLINDER	60261	5500A -2	2 - M 4		45613	4500A -1	1 - G 10
	76422	6110A -1	2 - G 7	HOLDER, LICENSE PLATE	50030	5000A -1	2 - D 3	HOSE, FUEL MAIN	13421	1320A -1	1 - K 3
	76429	6110A -1	2 - G 7		50340	5010A -1	2 - F 3		45127	4500A -1	1 - G 10
GUIDE 'A' (L), GLASS		5800A -1	2 - J 6	HOLDER, ROD	58309	5830A -1	2 - K 6	HOSE, FUEL RETURN	13422	1320A -1	1 - K 3
GUIDE 'A' (R), GLASS	58601	5800A -1	2 - J 6	HOOD	52310	5230A -1	2 - F 4		45611	4500A -1	1 - G 10
GUIDE, CENTER LOUVER	64811	5580A -1	2 - G 5	HOOD, METER	55410	5540A -1	2 - N 4	HOSE, HOT AIR	13344	1330A -1	1 - L 3
GUIDE, LOUVER	64820	5580A -1	2 - G 5	HOOK	40270	4000A -1	1 - I 9	HOSE, LIQUID		6132AB-1	2 - L 7
					40280	4000A -1	1 - I 9			6132A -1	2 - J 7
				HOOK (L), FRONT		5370A -1	2 - K 4			6132AC-2	2 - D 8
*** H ***				HOOK (R), FRONT	56290	5370A -1	2 - K 4	HOSE, OIL	14720	1500A -1	1 - K 4
HANDLE (L), OUTER		5830A -1	2 - K 6	HOOK SLIDE	62885	6330A -1	2 - M 8		14730	1500A -1	1 - K 4
HANDLE (L), PULL		5840A -2	2 - D 7	HOOK, REAR	56291	5370A -1	2 - K 4		19933	1910A -1	1 - N 5
HANDLE (R), OUTER	58420	5830A -1	2 - K 6	HOOK, TIE DOWN	56291	5370A -1	2 - K 4		19934	1910A -1	1 - N 5
HANDLE (R), PULL	69371	5840A -2	2 - D 7	HOOK, TRIM	69605	6840A -3	2 - E 11	HOSE, SCREW WASHER	67275	6750A -1	2 - I 10
HANDLE, INNER	58321	5830A -1	2 - K 6	HORN, AIR	23310	1360A -1	1 - C 4			6132A -1	2 - J 7
HANDLE, JACK	68810	3700A -2	1 - G 9	HORN, HIGH TONE	66780	6635A -1	2 - H 9	HOSE, SUCTION		13100	1380A -1
HANDLE, REGULATOR	58370	5830A -1	2 - K 6	HORN, LOW TONE	66790	6635A -1	2 - H 9		13242	1380A -1	1 - F 4
HANGER, COAT	69941	6900A -3	2 - K 11	HOSE	13527	1350A -1	1 - M 3		19904	1910A -1	1 - N 5
HANGER, ENGINE	10861	1040A -1	1 - E 3		76420	6110A -1	2 - G 7		43640	4340A -1	1 - C 10
	10862	1040A -1	1 - E 3	HOSE ASSEMBLY		6120A -1	2 - I 7		43836	4340A -1	1 - C 10
HANGER, SILENCER	40061	4000A -1	1 - I 9	HOSE BLOCK ASSEMBLY		6132AB-1	2 - L 7	HOSE, VENT	42316	4200A -1	1 - M 9
	40160	4000A -1	1 - I 9	HOSE NO. 1, FLEXIBLE	43810	6132AC-2	2 - D 8		42571	4200A -1	1 - M 9
HARNES ASSEMBLY, WIRING		6152A -1	2 - H 8		43810	4360AA-1	1 - E 10		42588	4200A -1	1 - M 9
HARNES, DOOR	67190	6703A -1	2 - D 10	HOSE NO. 1, WATER	61211	4360A -1	1 - D 10	HOSE, VENTILATION	13785	1320A -1	1 - K 3
HARNES, FLOOR	67120	6703A -1	2 - D 10	HOSE NO. 2, WATER	61212	4360AA-1	1 - E 10		13971	1320A -1	1 - K 3
HARNES, FRONT	67010	6700A -1	2 - M 9	HOSE NO. 3, WATER	61213	6100A -1	2 - F 7	HOSE, WATER	15351	1500A -2	1 - L 4
HARNES, INSTRUMENT	67030	6702A -1	2 - C 10	HOSE, AIR	13130	1380AA-1	1 - H 4		15351	1500AA-1	1 - M 4
HARNES, PARKING BRAKE	67120	6702A -1	2 - C 10		13130	1380A -1	1 - F 4	HOSE, WATER-COOLER	15187	1500AA-1	1 - M 4
HARNES, REAR	67050	6700A -1	2 - M 9		13296	1380AA-1	1 - H 4		15188	1500AA-1	1 - M 4
HARNES, TRANSMISSION	67090	6701A -1	2 - N 9		13296	1380A -1	1 - F 4	HOSE, WATER-HEATER	15189	1500AA-1	1 - M 4
		6132AB-1	2 - L 7		13650	1380A -1	1 - F 4	HOSE, WATER-LOWER	15186	1500AA-1	1 - M 4
		6132AC-1	2 - C 8		13650	1380A -1	1 - F 4		15186	1500A -1	1 - K 4
		6132A -2	2 - K 7		13650	1380A -1	1 - F 4	HOSE, WATER-UPPER	15185	1500AA-1	1 - M 4
		6152AC-1	2 - J 8		13717	1320A -1	1 - K 3		15185	1500A -1	1 - K 4
		6152AC-1	2 - J 8		13717	1371A -1	1 - E 4	HOUSING, CONVERTER	19211	1910A -1	1 - N 5
		6152AB-1	2 - I 8		13718	1371A -1	1 - E 4	HOUSING, EXTENSION	17330	1700A -1	1 - D 5
		6152AB-1	2 - I 8		13725	1371A -1	1 - E 4		19710	1920A -1	1 - C 6
		6152A -1	2 - H 8		13755	1380A -1	1 - F 4	HOUSING, FRONT	10200	1040A -1	1 - E 3
HEAD, CYLINDER		6142AB-1	2 - F 8		13755	1380AA-1	1 - H 4	HOUSING, GEAR	32120	3210A -1	1 - M 8
		6142AC-1	2 - G 8		13755	1380AA-1	1 - H 4	HOUSING, INTERMEDIATE	10400	1030A -1	1 - D 3
		6142A -1	2 - E 8		13756	1380A -1	1 - F 4	HOUSING, REAR	10300	1040A -1	1 - E 3
HEADER, FRONT	70640	5340A -1	2 - I 4		13756	1380AA-1	1 - H 4	HOUSING, ROTOR	10100	1030A -1	1 - D 3
HEADER, REAR	70700	5340A -1	2 - I 4		20950	1380A -1	1 - F 4	HUB, CLUTCH	17241	1710A -1	1 - E 5
HEATER UNIT	61130	6100A -1	2 - F 7		40728	4000A -2	1 - J 9		17261	1710A -1	1 - E 5
HINGE 'A' (L), TOP	63860	6330A -1	2 - M 8		D8P04	1380AA-1	1 - H 4		17321	1710A -2	1 - F 5
HINGE 'A' (R), TOP	62860	6330A -1	2 - M 8		D8P06	1380AA-1	1 - H 4	HUB, REAR CLUTCH	19530	1930A -1	1 - E 6
HINGE 'B', TOP	62870	6330A -1	2 - M 8		D8P08	1380AA-1	1 - H 4		19531	1930A -1	1 - E 6
HINGE (L)	63210	6230A -1	2 - K 8	HOSE, BREATHER	42581	4200A -1	1 - M 9				
HINGE (L), DOOR-LOWER		5830A -1	2 - K 6	HOSE, DEFROSTER	61251	5580A -1	2 - G 5	*** ***			
HINGE (L), DOOR-UPPER		5830A -1	2 - K 6	HOSE, DISCHARGE		6132A -1	2 - J 7	IGNITER SET	24910	1820A -1	1 - I 5
HINGE (L), LID-LAMP		5103A -1	2 - K 3	HOSE, DRAIN		6152A -1	2 - H 8	INDICATOR	64340	5570A -1	2 - E 5
HINGE (R)	62210	6230A -1	2 - K 8			6152AB-1	2 - I 8	INDICATOR, LEVEL	43540	4340A -1	1 - C 10
HINGE (R), DOOR-LOWER	58240	5830A -1	2 - K 6			6152AC-1	2 - J 8	INSULATION	72852	5830A -2	2 - L 6
HINGE (R), DOOR-UPPER	58210	5830A -1	2 - K 6		13973	1320A -1	1 - K 3	INSULATOR	13315	1320A -1	1 - K 3
HINGE (R), LID-LAMP	51430	5103A -1	2 - K 3		74030	6330A -1	2 - M 8				

ALPHABETICAL INDEX

PART NAME	D-CODE	SECTION	LOCATION	PART NAME	D-CODE	SECTION	LOCATION	PART NAME	D-CODE	SECTION	LOCATION
INSULATOR	40085	4000A -1	1 - I 9		66908	6680A -1	2 - J 9		76471	6120A -1	2 - I 7
	40401	4000A -1	1 - I 9	KNOB, RESISTOR	55492	5540A -1	2 - N 4		76501	6115A -1	2 - H 7
	40405	4000A -1	1 - I 9	KNOB, TRIPMETER	55472	5540A -1	2 - N 4		76502	6115A -1	2 - H 7
	56981	5370A -1	2 - K 4	KNUCKLE (L), RECLINING	88151	5700AA-4	2 - F 6	LEVER, PARKING BRAKE	44010	4400A -1	1 - F10
	64492	5570A -2	2 - F 5		88151	5700A -3	2 - J 5	LEVER, SELECT	19031	1950A -1	1 - H 6
INSULATOR NO. 1, REAR	56480	5370A -1	2 - K 4	KNUCKLE (R), RECLINING	88101	5700AA-1	2 - C 6		46010	4600A -1	1 - H10
INSULATOR NO. 2, FRONT	56440	5370A -1	2 - K 4		88101	5700A -1	2 - H 5	LID (L), LAMP		5103A -1	2 - K 3
INSULATOR NO. 4, REAR	56460	5370A -1	2 - K 4	*** L ***				LID (M), LAMP	51421	5103A -1	2 - K 3
INSULATOR, DASH-UPPER	68664	6860A -1	2 - F11	LABEL, CAUTION-MVSS	69034	6930A -1	2 - L11	LID, CONSOLE	64450	5570A -2	2 - F 5
INSULATOR, DASHBOARD	68620	6860A -1	2 - F11	LABEL, EMISSION	69041	6930A -1	2 - L11	LID, FUEL FILLER	42410	4200A -1	1 - M 9
INSULATOR, HEAT	13371	1310A -1	1 - J 3	LABEL, GASOLINE	69038	6930A -1	2 - L11	LID, GLOVE POCKET	64030	5560A -2	2 - D 5
	56431	5370A -1	2 - K 4	LABEL, OIL	69013	6930A -1	2 - L11	LIGHTER, CIGAR	66250	6610A -1	2 - C 9
INSULATOR, HEAT-FRONT	56410	5370A -1	2 - K 4	LABEL, TEMPORARY TIRE	69014	6930A -1	2 - L11	LINK	28200	2800A -1	1 - J 8
INSULATOR, LOWER	39384	3900A -1	1 - H 9	LABEL, TIRE	69014	6930A -1	2 - L11	LINK (L), WATT	28170	2800A -1	1 - J 8
INSULATOR, TANK-FUEL	56991	5370A -1	2 - K 4	LABEL, VACUUM DIAPHRAGM	69044	6930A -1	2 - L11	LINK (R), WATT	28160	2800A -1	1 - J 8
INSULATOR, UPPER	39385	3900A -1	1 - H 9	LAMP SET (L), FRONT COMB.	51060	5105A -1	2 - L 3	LINK, FUSIBLE	18055	6701A -1	2 - N 9
*** J ***				LAMP SET (L), HEAD	51030	5100A -1	2 - J 3		67099	6700A -1	2 - M 9
JACK	68800	3700A -2	1 - G 9	LAMP SET (L), RR. COMB.	51150	5110A -1	2 - M 3		67099	6700A -1	2 - M 9
JET SET, MAIN 1ST	23353	1360A -1	1 - C 4	LAMP SET (L), SIDE TURN	51120	5105A -1	2 - L 3	LINK, LOWER	28300	2800A -1	1 - J 8
JET SET, MAIN 2ND	23402	1360A -1	1 - C 4		51550	5120A -1	2 - N 3	LINK, WIPER	76601	6730A -1	2 - G10
JET SET, SLOW	23407	1360A -2	1 - D 4	LAMP SET (R), FRONT COMB.	51060	5105A -1	2 - L 3	LINKAGE, CENTER	32261	3230A -1	1 - N 8
JET, AIR BLEED	23492	1360A -2	1 - D 4	LAMP SET (R), HEAD	51030	5100A -1	2 - J 3	LOCK (L), DOOR		5830A -1	2 - K 6
JET, AIR BLEED 1ST	23424	1360A -2	1 - D 4	LAMP SET (R), RR. COMB.	51150	5110A -1	2 - M 3	LOCK (R), DOOR	58310	5830A -1	2 - K 6
JET, AIR BLEED 2ND	23433	1360A -2	1 - D 4	LAMP SET (R), SIDE TURN	51120	5105A -1	2 - L 3	LOCK, BACK DOOR	62310	6230A -1	2 - K 8
JET, SLOW AIR BLEED	23425	1360A -2	1 - D 4		51550	5120A -1	2 - N 3	LOCK, FILLER LID	42440	0900A -1	2 - C 3
JET, STEP	23397	1360A -1	1 - C 4	LAMP SET, LICENSE	51270	5120A -1	2 - N 3	LOCK, HOOD	56620	5230A -1	2 - F 4
JET, STEP AIR BLEED	23434	1360A -2	1 - D 4	LAMP, CARGO ROOM	51440	5125A -1	2 - C 4	LOCKWASHER		6132AC-1	2 - C 8
JOINT	43642	4360AA-1	1 - E10	LAMP, SPOT	51355	6900A -1	2 - I11			6142AB-1	2 - F 8
	58314	5830A -1	2 - K 6	LATCH, ROTARY	62881	6330A -1	2 - M 8			6142AC-1	2 - G 8
JOINT SET, BALL	32240	3230A -1	1 - N 8	LENS	51441	5125A -1	2 - C 4	LOUVER, CENTER	64815	5580A -1	2 - G 5
	32280	3230A -1	1 - N 8	LENS (L), FRONT COMB.		5105A -1	2 - L 3	LOUVER, VENTILATOR	70371	5580A -1	2 - G 5
JOINT SET, UNIVERSAL	25060	2500A -1	1 - C 8	LENS (L), RR. COMB.		5110A -1	2 - M 3	*** M ***			
JOINT, MOULDING-UPPER	50604	5030A -1	2 - G 3	LENS (L), SIDE TURN		5105A -1	2 - L 3	MANIFOLD, EXHAUST	13450	1310A -1	1 - J 3
JOINT, PIPE	10417	1030A -1	1 - D 3			5120A -1	2 - N 3	MANIFOLD, INTAKE	13100	1300A -1	1 - I 3
JOINT, UNION	10600	1040A -1	1 - E 3	LENS (R), FRONT COMB.	51063	5105A -1	2 - L 3	MAT, FRONT FLOOR	68674	6860A -1	2 - F11
	14720	1500A -1	1 - K 4	LENS (R), RR. COMB.	51161	5110A -1	2 - M 3	MAT, REAR FLOOR	68677	6860A -1	2 - F11
*** K ***				LENS (R), SIDE TURN	51122	5105A -1	2 - L 3	MAT, TRUNK ROOM	68695	6860A -1	2 - F11
KEY	11512	1100A -1	1 - G 3		51552	5120A -1	2 - N 3	MEMBER NO. 3, CROSS	53900	5360A -1	2 - J 4
	14119	1400AA-1	1 - J 4	LENS, ASH TRAY	55215	5500A -1	2 - L 4	MEMBER NO. 4, CROSS	53940	5360A -1	2 - J 4
	14119	1400A -1	1 - I 4	LENS, INTERIOR MIRROR	69223	6900A -2	2 - J11	MEMBER NO. 5, CROSS	53960	5360A -1	2 - J 4
KEY SET	09010	0900A -1	2 - C 3	LENS, LAMP	60224	5500A -2	2 - M 4	MEMBER, CROSS	34800	3410A -1	1 - E 9
KEY SUB SET (L), DOOR	75920	0900A -1	2 - C 3	LENS, LICENSE LAMP	51273	5120A -1	2 - N 3		53162	5360A -1	2 - J 4
KEY SUB SET (R), DOOR	75910	0900A -1	2 - C 3	LENS, WARNING	55447	5540A -1	2 - N 4	MEMBER, TRANSMISSION MOUNTING	39380	3900A -1	1 - H 9
KEY SUB SET, BACK DOOR	75960	0900A -1	2 - C 3	LEVER	24730	1840A -1	1 - K 5	METER, FUEL & TEMPERATURE	55491	5540A -1	2 - N 4
KEY SUB SET, GLOVE	75950	0900A -1	2 - C 3		46055	4600A -1	1 - H10	MIRROR (L), REAR VIEW	69130	6900A -1	2 - I11
KEY SUB SET, STEERING	75990	0900A -1	2 - C 3	LEVER (L), LINK	46150	4600A -1	1 - H10	MIRROR (R), REAR VIEW	69110	6900A -1	2 - I11
KEY, BLANK	75158	0900A -1	2 - C 3	LEVER (L), OPERATING		5103A -1	2 - K 3	MIRROR, INTERIOR	69170	6900A -2	2 - J11
KEY, FLYWHEEL	11705	1100A -1	1 - G 3	LEVER (L), PAWL		2610A -1	1 - F 8	MOTOR	13083	1350A -1	1 - M 3
KEY, PRIMARY	58492	0900A -1	2 - C 3	LEVER (R), LINK	51935	5103A -1	2 - K 3		67450	6750A -1	2 - I10
KEY, SHAFT		6142AC-1	2 - G 8	LEVER (R), OPERATING	26800	2610A -1	1 - F 8	MOTOR & LINK (L)		5103A -1	2 - K 3
		6142AB-1	2 - F 8	LEVER (R), PAWL	26808	2610A -1	1 - F 8	MOTOR & LINK (R)	51930	5103A -1	2 - K 3
		6142A -1	2 - E 8	LEVER NO. 1, CONTROL	76407	6110A -1	2 - G 7	MOTOR (L)		5103A -1	2 - K 3
KEY, SYNCHRONIZER	17243	1710A -1	1 - E 5	LEVER NO. 2, CONTROL	76409	6110A -1	2 - G 7	MOTOR (L), WINDOW		5830A -2	2 - L 6
KNOB	51937	5103A -1	2 - K 3	LEVER SET, FRONT	23420	1360A -2	1 - D 4	MOTOR (R)	51931	5103A -1	2 - K 3
	61196	6100A -1	2 - F 7	LEVER SET, REAR	23430	1360A -2	1 - D 4	MOTOR (R), WINDOW	58580	5830A -1	2 - K 6
KNOB NO. 1	61191	6100A -1	2 - F 7	LEVER, ADJUST	46160	4600A -1	1 - H10	MOTOR, FAN	76424	6120A -1	2 - I 7
KNOB, A/C	61197	6100A -1	2 - F 7	LEVER, CHANGE	17510	1720A -1	1 - G 5		76424	6120A -1	2 - I 7
KNOB, CHANGE LEVER	17520	1720A -1	1 - G 5	LEVER, CONTROL	17461	1720A -1	1 - G 5	MOTOR, WIPER	67350	6730A -1	2 - G10
	46030	4600A -1	1 - H10		23844	1400A -1	1 - I 4	MOULDING (L), DRIP	50451	5040A -1	2 - H 3
KNOB, DOOR LOCK	58691	5830A -2	2 - L 6		23844	1400AA-1	1 - J 4	MOULDING (L), GLASS	63980	6300A -1	2 - L 8
KNOB, KNUCKLE	88081	5700A -1	2 - H 5		76408	6110A -1	2 - G 7	MOULDING (R), DRIP	50441	5040A -1	2 - H 3
KNOB, LUMBAR SUPPORT	88140	5700AA-4	2 - F 6		76411	6110A -1	2 - G 7	MOULDING (R), GLASS	63970	6300A -1	2 - L 8
KNOB, PLAYER	66906	6680A -1	2 - J 9		76412	6110A -1	2 - G 7				

ALPHABETICAL INDEX

PART NAME	D-CODE	SECTION	LOCATION	PART NAME	D-CODE	SECTION	LOCATION	PART NAME	D-CODE	SECTION	LOCATION
MOULDING SET (L), FRONT-SIDE	50504	5030A-1	2-G 3		56905	5540A-1	2-N 4		19836	1920A-2	1-D 6
MOULDING SET (L), FRONT-UPPER	50502	5030A-1	2-G 3	NUT, STOPPER	14822	1500A-1	1-K 4	PANEL (L), COWL SIDE	71020	5340A-1	2-I 4
MOULDING SET (R), FRONT-SIDE	50503	5030A-1	2-G 3	NUT, STRIKER	62365	6230A-1	2-K 8	PANEL (L), FENDER-FRONT	52210	5310A-1	2-G 4
MOULDING SET (R), FRONT-UPPER	50501	5030A-1	2-G 3	NUT, TENSION ROD	34133	3410A-1	1-E 9	PANEL (L), FENDER-REAR	74130	5340A-1	2-I 4
MOULDING SET, FRONT-LOWER	50505	5030A-1	2-G 3					PANEL (L), OUTER		5800A-1	2-J 6
MOULDING, REAR WINDOW	63935	6300A-1	2-L 8	*** O ***				PANEL (L), QUARTER	71100	5340A-1	2-I 4
MOUNTING, COMPRESSOR		6142AC-1	2-G 8	O-RING		6152AC-1	2-J 8	PANEL (L), SIDE	56380	5310A-1	2-G 4
		6142AB-1	2-F 8			6152AB-1	2-I 8	PANEL (L), SIDE SEAL	54950	5360A-1	2-J 4
*** N ***					10173	1030A-1	1-D 3	PANEL (L), SIDE SILL	71270	5340A-1	2-I 4
NAME, SIDE	51721	5170A-1	2-D 4		10174	1040A-1	1-E 3	PANEL (L), WHEEL APRON	54210	5310A-1	2-G 4
NOZZLE	67490	6750A-1	2-I 10		10555	1030A-1	1-D 3	PANEL (R), COWL SIDE	70020	5340A-1	2-I 4
NOZZLE (L), DEFROSTER	60140	5580A-1	2-G 5		11400	1100A-1	1-G 3	PANEL (R), FENDER-FRONT	52110	5310A-1	2-G 4
NOZZLE (R), DEFROSTER	60120	5580A-1	2-G 5		13100	1300A-1	1-I 3	PANEL (R), FENDER-REAR	74100	5340A-1	2-I 4
NOZZLE SET, ACCELERATOR	23490	1360A-2	1-D 4		14300	1400AA-1	1-J 4	PANEL (R), OUTER	58020	5800A-1	2-J 6
NOZZLE, WASHER	67510	6720A-1	2-F 10		14300	1400A-1	1-I 4	PANEL (R), QUARTER	70100	5340A-1	2-I 4
NUT		6142A-1	2-E 8		17442	1700A-1	1-D 5	PANEL (R), SIDE	56370	5310A-1	2-G 4
		6152AC-1	2-J 8		18201	1800A-1	1-H 5	PANEL (R), SIDE SILL	53950	5360A-1	2-J 4
	13461	1310A-1	1-J 3		19395	1920A-1	1-C 6		70270	5340A-1	2-I 4
	19389	1920A-1	1-C 6		19396	1920A-1	1-C 6	PANEL (R), WHEEL APRON	53210	5310A-1	2-G 4
	23847	1400AA-1	1-J 4		19432	1950A-1	1-H 6	PANEL, CENTER	55220	5500A-1	2-L 4
	23847	1400A-1	1-I 4		19442	1920A-1	1-C 6	PANEL, COWL	74040	5310A-2	2-H 4
	25125	2500AA-1	1-D 8		19446	1950A-1	1-H 6	PANEL, COWLING UP	56391	5310A-1	2-G 4
	33042	3300A-1	1-C 9		19870	1920A-2	1-D 6	PANEL, DASH-LOWER	53400	5310A-1	2-G 4
	34222	3410A-1	1-E 9		23837	1400A-1	1-I 4	PANEL, DASH-UPPER	53510	5310A-1	2-G 4
	40355	4000A-1	1-I 9		23837	1400AA-1	1-J 4	PANEL, DECORATION	55270	5500A-1	2-L 4
	46061	4600A-1	1-H 10	O-RING PACKAGE SET	34731	3400A-1	1-D 9	PANEL, DECORATION-SWITCH	55215	5500A-1	2-L 4
	62635	6750A-1	2-I 10			6132AC-1	2-C 8	PANEL, GLOVE SIDE	55301	5500A-1	2-L 4
	66372	6750A-1	2-I 10	O-RING SET		6132AB-2	2-M 7	PANEL, NOSE	52810	5310A-1	2-G 4
	76472	6120A-1	2-I 7			6142A-1	2-E 8	PANEL, RADIATOR SHROUD	53100	5310A-1	2-G 4
	87134	6730A-1	2-G 10			6142AC-1	2-G 8	PANEL, REAR END	70750	5340A-1	2-I 4
	87134	6750A-1	2-I 10			6142AB-1	2-F 8	PANEL, ROOF	74030	5340A-1	2-I 4
NUT, CAP	76603	6730A-1	2-G 10		23040	1000A-1	1-C 3	PANEL, SKIRT-REAR	70791	5340A-1	2-I 4
NUT, CLIP	50825	5310A-1	2-G 4	O-RING, CAP-TUBE SEAL		6152AC-1	2-J 8	PANEL, SWITCH	55311	5500A-1	2-L 4
	50825	5000A-1	2-D 3		11341	1110A-1	1-H 3		64345	5570A-1	2-E 5
NUT, CLIP-FRONT FENDER	52841	5310A-1	2-G 4	O-RING, INNER	11343	1110A-1	1-H 3	PARTS KIT, INNER	49460	4140A-1	1-K 9
NUT, CLIP-PROTECTOR	50825	5370A-1	2-K 4	O-RING, OUTER	42480	4200A-1	1-M 9		49520	4140A-1	1-K 9
NUT, CROSS MEMBER	39349	3410A-1	1-E 9	OPENER, FILLER LID	62315	6230A-1	2-K 8		49640	4340A-1	1-C 10
NUT, DAMPER	62635	6230A-1	2-K 8	OPENER, REMOTE CONTROL	51771	5170A-1	2-D 4	PARTS SET	76619	6740A-1	2-H 10
NUT, FLANGE	40355	4000A-1	1-I 9	ORNAMENT, FRONT	51781	5170A-1	2-D 4		76619	6760A-1	2-J 10
NUT, HEX		6132AC-1	2-C 8	ORNAMENT, REAR	55231	6680A-1	2-J 9	PARTS SET, BRAKE CYLINDER	49610	4340A-1	1-C 10
		6132AB-1	2-L 7	ORNAMENT, STEREO	55991	6680A-1	2-J 9	PASS, OIL	17540	1700A-1	1-D 5
		6132A-1	2-J 7	ORNAMENT, TUNER	66915	6680A-2	2-K 9	PAWL, PARKING	19732	1950A-1	1-H 6
		6142AB-1	2-F 8		67690	6630A-1	2-G 9	PEDAL & ARM	41610	4160A-1	1-L 9
		6142AC-1	2-G 8	OSCILLATOR				PEDAL, BRAKE	43030	4300A-1	1-N 9
		6152A-1	2-H 8		*** p ***			PEDAL, CLUTCH	41030	4300A-1	1-N 9
		6152AB-1	2-I 8	PACKING	51902	6300A-1	2-L 8	PELLET, THERMO	14810	1500A-1	1-K 4
NUT, HEXAGON	23452	1360A-2	1-D 4		67511	6720A-1	2-F 10	PICK-UP SET	24314	1820A-1	1-I 5
NUT, HINGE	51433	5103A-1	2-K 3		68951	5180A-1	2-E 4	PIECE, DISTANCE	27171	2700A-1	1-H 10
NUT, KEPS		6132A-1	2-J 7	PAD (C), FLOOR-FRONT	76124	6120A-1	2-I 7	PIECE, SIDE	11302	1110A-1	1-H 3
		6132AC-1	2-C 8	PAD (C), FLOOR-REAR	68651	6860A-1	2-F 11	PILLAR (L), FRT.-INNER	71260	5340A-1	2-I 4
		6132AB-1	2-L 7	PAD (L), FLOOR-TRUNK	68654	6860A-1	2-F 11	PILLAR (L), HINGE	71210	5340A-1	2-I 4
		6152A-1	2-H 8	PAD, ACCELERATOR	68666	6860A-1	2-F 11	PILLAR (L), HINGE-OUTER	74120	5340A-1	2-I 4
NUT, LOCK	11711	1100A-1	1-G 3	PAD, CHOKE WIRE	41711	4160A-1	1-L 9	PILLAR (R), FRT.-INNER	70260	5340A-1	2-I 4
	17524	1720A-1	1-G 5	PAD, CRUSH	56942	5500A-2	2-M 4	PILLAR (R), HINGE	70210	5340A-1	2-I 4
	17629	1710A-2	1-F 5	PAD, FOOT REST	60350	5560A-1	2-C 5	PILLAR (R), HINGE-OUTER	74090	5340A-1	2-I 4
	27030	2700A-1	1-H 8	PAD, FUEL TANK	86202	4300A-1	1-N 9	PIN	19434	1950A-1	1-H 6
NUT, LOCK PLATE	76626	6750A-1	2-I 10	PAD, PEDAL	42523	4200A-1	1-M 9		27262	2700A-2	1-I 8
NUT, RING	55493	5540A-1	2-N 4	PAD, STORAGE BOX	43028	4300A-1	1-N 9		33698	3300A-1	1-C 9
NUT, SET	24533	1830A-1	1-J 5	PAD, SUB SET	68658	6860A-1	2-F 11		44054	4400A-1	1-F 10
NUT, SHAFT	19443	1950A-1	1-H 6		49280	2610AA-1	1-G 8		46035	4600A-1	1-H 10
NUT, SPEED	69049	5170A-1	2-D 4	PAD, TRUNK SIDE	49280	3300A-1	1-C 9		46683	4300A-1	1-N 9
	69049	6300A-1	2-L 8	PAN, FLOOR-FRONT	68667	6860A-1	2-F 11	PIN & WASHER SET	13717	1360A-1	1-C 4
NUT, SPRING	55905	5540A-1	2-N 4	PAN, FLOOR-REAR	53600	5360A-1	2-J 4	PIN (L)		2610A-1	1-F 8
	56905	5500A-2	2-M 4	PAN, OIL	53700	5360A-1	2-J 4	PIN (R)	26832	2610A-1	1-F 8
					10400	1040A-1	1-E 3	PIN, BRAKE SHOE	26391	2610A-1	1-F 8

ALPHABETICAL INDEX

PART NAME	D-CODE	SECTION	LOCATION	PART NAME	D-CODE	SECTION	LOCATION	PART NAME	D-CODE	SECTION	LOCATION
PIN, COTTER	13717	1360A -1	1 - C 4	PLATE	11501	1100A -1	1 - G 3		23541	1360A -2	1 - D 4
PIN, DAMPER	62621	6230A -1	2 - K 8		40071	4000A -1	1 - I 9	PLUG SET	23354	1360A -1	1 - C 4
PIN, DOWEL	10203	1040A -1	1 - E 3		40170	4000A -1	1 - I 9	PLUG, BACK PLATE	26288	2610A -1	1 - F 8
PIN, DRIVEN GEAR	14623	1400A -1	1 - I 4		43090	4300A -1	1 - N 9	PLUG, BLIND	10205	1040A -1	1 - E 3
	14623	1400AA-1	1 - J 4		51356	6900A -1	2 - I 1		10206	1040A -1	1 - E 3
PIN, GUIDE	46022	4600A -1	1 - H 10		67562	6630A -1	2 - G 9		10207	1040A -1	1 - E 3
PIN, INTER LOCK	17351	1720A -1	1 - G 5		76421	6115A -1	2 - H 7		11405	1100A -1	1 - G 3
PIN, PIVOT	16102	1600A -1	1 - C 5	PLATE (L), BRAKE BACK		2610A -1	1 - F 8	PLUG, CAP	17442	1720A -1	1 - G 5
PIN, SPRING	10609	1040A -1	1 - E 3	PLATE (L), CLOSING	54270	5310A -1	2 - G 4	PLUG, CHECK BALL	23338	1360A -1	1 - C 4
PIN, TOP INDICATOR	10503	1040A -1	1 - E 3	PLATE (L), CLOSING-REAR	54222	5310A -1	2 - G 4	PLUG, CORNER SEAL	11322	1110A -1	1 - H 3
PIN, TUBULAR	10309	1040A -1	1 - E 3	PLATE (L), FRONT SCUFF	68721	6840A -2	2 - D 11	PLUG, DRAIN	10404	1040A -1	1 - E 3
PINION	24709	1840A -1	1 - K 5	PLATE (L), GLASS	63970	6300A -1	2 - L 8		53134	6100A -1	2 - F 7
PINION, DIFFERENTIAL	27255	2700A -2	1 - I 8	PLATE (L), SEAL	56366	5310A -1	2 - G 4		56241	5370A -1	2 - K 4
PIPE	13945	6640A -1	2 - I 9	PLATE (R), BRAKE BACK	26280	2610A -1	1 - F 8		56241	6704A -1	2 - E 10
	13945	6640A -1	2 - I 9	PLATE (R), CLOSING	53270	5310A -1	2 - G 4		56241	6100A -1	2 - F 7
	18107	1800A -1	1 - H 5	PLATE (R), CLOSING-REAR	53222	5310A -1	2 - G 4		56241	6100A -1	2 - F 7
	40070	4000A -1	1 - I 9	PLATE (R), FRONT SCUFF	68711	6840A -2	2 - D 11		56242	5370A -1	2 - K 4
	66945	6680A -2	2 - K 9	PLATE (R), GLASS	63960	6300A -1	2 - L 8	PLUG, HOLE	61031	6100A -1	2 - F 7
	67500	6720A -1	2 - F 10	PLATE (R), SEAL	56365	5310A -1	2 - G 4	PLUG, MAGNET DRAIN	17121	1700A -1	1 - D 5
	76416	6110A -1	2 - G 7	PLATE (R), LOCK	62883	6330A -1	2 - M 8		26051	2600A -1	1 - E 8
	76417	6110A -1	2 - G 7	PLATE MODEL	69011	6930A -1	2 - L 11	PLUG, OIL FILLER		6142AC-1	2 - G 8
PIPE (L), BRAKE-FRONT	45320	4360AA-1	1 - E 10	PLATE SET	50211	5010A -1	2 - F 3	PLUG, OIL JET	11411	1100A -1	1 - G 3
	45320	4360A -1	1 - D 10	PLATE, ABSORBER	13380	1310A -1	1 - J 3	PLUG, OIL LEVEL	26041	2600A -1	1 - E 8
PIPE (L), BRAKE-REAR	43650	4360A -1	1 - D 10	PLATE, ADJUST	34013	3400A -1	1 - D 9	PLUG, SERVICE COVER	58868	4000A -2	1 - J 9
	43650	4360AA-1	1 - E 10	PLATE, CEILING-FRONT	68051	6800A -1	2 - K 10	PLUG, SPARK	18110	1800A -1	1 - H 5
PIPE (R), BRAKE-FRONT	45280	4360AA-1	1 - E 10	PLATE, DISC	26251	2610AA-1	1 - G 8	PLUG, SQUARE HEAD	19331	1920A -1	1 - C 6
	45280	4360A -1	1 - D 10	PLATE, DISHED	19498	1930A -1	1 - E 6	PLUNGER, CONTROL	14275	1040A -2	1 - F 3
PIPE (R), BRAKE-REAR	43660	4360AA-1	1 - E 10		19608	1940A -1	1 - G 6	POLE, ANTENNA	66941	6680A -2	2 - K 9
	43660	4360A -1	1 - D 10	PLATE, DRIVE	19020	1910A -1	1 - N 5	PORT, SERVICE		6142AC-1	2 - G 8
PIPE SET, VACUUM	23509	1360A -2	1 - D 4		19500	1930A -1	1 - E 6	PROTECTOR	10735	1040A -1	1 - E 3
PIPE, AIR	40720	4000A -2	1 - J 9	PLATE, DRIVEN	19610	1940A -1	1 - G 6		14746	1400AA-1	1 - J 4
PIPE, AIR INTAKE	23615	1330A -1	1 - L 3		19499	1930A -1	1 - E 6		34152	3410A -1	1 - E 9
PIPE, BRAKE-FRONT	45250	4360A -1	1 - D 10	PLATE, DUST SEAL	19609	1940A -1	1 - G 6		41692	6720A -1	2 - F 10
	45250	4360AA-1	1 - E 10		15118	1500AA-1	1 - M 4		50012	5000A -1	2 - D 3
PIPE, BRAKE-REAR	45350	4360A -1	1 - D 10	PLATE, FACE	15118	1500A -1	1 - K 4		50013	5010A -1	2 - F 3
	45350	4360AA-1	1 - E 10	PLATE, FRICTION	66915	6680A -1	2 - J 9		50014	5000A -1	2 - D 3
	45360	4360AA-1	1 - E 10	PLATE, HEATER UNIT	27258	2700A -2	1 - I 8		50014	5010A -1	2 - F 3
	45360	4360A -1	1 - D 10	PLATE, HOLDER-BRUSH	76511	6110A -1	2 - G 7		50016	5000A -1	2 - D 3
PIPE, BREATHER	42390	4200A -1	1 - M 9	PLATE, HUB/DISK	76612	6760A -1	2 - J 10		51051	6680A -1	2 - J 9
PIPE, CLUTCH	41370	4140A -1	1 - K 9	PLATE, LOCK	33251	3300A -1	1 - C 9		51403	5103A -1	2 - K 3
PIPE, EVAPORATION	45711	4500A -1	1 - G 10		27302	2700A -2	1 - I 8		51966	5180A -1	2 - E 4
	45712	4500A -1	1 - G 10	PLATE, MANUAL	42376	4200A -1	1 - M 9		60721	6610A -1	2 - C 9
PIPE, EVAPORATION DRAIN	45713	4500A -1	1 - G 10	PLATE, MAT SET	69762	6900A -3	2 - K 11		61216	6100A -1	2 - F 7
PIPE, EXHAUST-FRONT	49050	4000A -1	1 - I 9	PLATE, MIDDLE	14118	1400AA-1	1 - J 4		66312	6640A -1	2 - I 9
PIPE, FILLER	42210	4200A -1	1 - M 9		14118	1400A -1	1 - I 4	PROTECTOR 'A' (L), SIDE	50697	5060A -1	2 - I 3
PIPE, FUEL MAIN	45111	4500A -1	1 - G 10	PLATE, PRINT	55442	5540A -1	2 - N 4	PROTECTOR 'A' (R), SIDE	50692	5060A -1	2 - I 3
	45112	4500A -1	1 - G 10	PLATE, RETAINER	19667	1940A -1	1 - G 6	PROTECTOR 'B' (L), SIDE	50686	5060A -1	2 - I 3
PIPE, FUEL RETURN	45611	4500A -1	1 - G 10		55214	5500A -1	2 - L 4	PROTECTOR 'B' (R), SIDE	50681	5060A -1	2 - I 3
PIPE, HEATER	61220	6100A -1	2 - F 7	PLATE, RETAINING	19503	1930A -1	1 - E 6	PROTECTOR 'C' (L), SIDE	50682	5060A -1	2 - I 3
PIPE, OIL	19920	1910A -1	1 - N 5		19515	1930A -1	1 - E 6	PROTECTOR 'C' (R), SIDE	50682	5060A -1	2 - I 3
	19930	1910A -1	1 - N 5	PLATE, SET-FENDER	19613	1940A -1	1 - G 6	PROTECTOR 'D' (L), SIDE	50688	5060A -1	2 - I 3
PIPE, OIL COOLER	14740	1400AA-1	1 - J 4	PLATE, SETABILIZER	19702	1950A -1	1 - H 6	PROTECTOR 'D' (R), SIDE	50683	5060A -1	2 - I 3
PIPE, OIL FILLER	10410	1030A -1	1 - D 3	PLATE, THRUST	52151	5310A -1	2 - G 4	PROTECTOR 'E' (L), SIDE	50689	5060A -1	2 - I 3
PIPE, PEDAL	43061	4300A -1	1 - N 9		34155	3410A -1	1 - E 9	PROTECTOR 'E' (R), SIDE	50684	5060A -1	2 - I 3
PIPE, PRE-AIR	40750	4000A -2	1 - J 9	PLATE, UPPER	11504	1100A -1	1 - G 3	PROTECTOR NO. 1	40810	4000A -2	1 - J 9
PIPE, VACUUM	13650	1380AA-1	1 - H 4	PLATE, WATER BAFFLE	13129	1300A -1	1 - I 3	PROTECTOR NO. 2	40820	4000A -2	1 - J 9
	13650	1380A -1	1 - F 4		64340	5570A -1	2 - E 5	PROTECTOR NO. 4	40840	4000A -2	1 - J 9
	19910	1910A -1	1 - N 5	PLATE, WINDOW	15125	1500AA-1	1 - M 4	PROTECTOR, BRAKE PIPE	43605	4360AA-1	1 - E 10
	43830	4340A -1	1 - C 10	PLAYER, TAPE-CASSETTE	15125	1500A -1	1 - K 4		43605	4360A -1	1 - D 10
	43840	4340A -1	1 - C 10	PLUG	75011	5540A -1	2 - N 4		43609	4360A -1	1 - D 10
PIPE VINYL	4030	6330A -1	2 - M 8		66860	6680A -1	2 - J 9		43609	4360AA-1	1 - E 10
PISTON	26666	2610AA-1	1 - G 8		14274	1040A -2	1 - F 3	PROTECTOR, CORD	51516	5105A -1	2 - L 3
	33651	3300A -1	1 - C 9		20547	4000A -1	1 - I 9	PROTECTOR, COWL GRILLE	50781	5180A -1	2 - E 4
PISTON, BAND SERVO	19381	1920A -1	1 - C 6					PROTECTOR, FUEL PUMP	45151	4500A -1	1 - G 10
PISTON, CLUTCH	19480	1930A -1	1 - E 6								
PISTON, LOW & REVERSE	19601	1940A -1	1 - G 6								

ALPHABETICAL INDEX

PART NAME	D-CODE	SECTION	LOCATION	PART NAME	D-CODE	SECTION	LOCATION	PART NAME	D-CODE	SECTION	LOCATION
SCREW		6132AC-1	2 - C 8	SEAL, O-RING	19475	1930A -1	1 - E 6	SHEET	42331	4200A -1	1 - M 9
	44187	4400A -1	1 - F10		19604	1940A -1	1 - G 6		42413	4200A -1	1 - M 9
	50950	5180A -1	2 - E 4		19822	1920A -1	1 - C 6	SHEET 'A', SIDE WINDOW	70526	6300A -1	2 - L 8
	62878	6330A -1	2 - M 8	SEAL, OIL	10507	1040A -1	1 - E 3	SHEET, RUBBER	28013	2800A -1	1 - J 8
	62879	6330A -1	2 - M 8		10556	1030A -1	1 - D 3		34012	3400A -1	1 - D 9
	62980	6330A -1	2 - M 8		11404	1100A -1	1 - G 3	SHEET, SPRING-UPPER	34340	3400A -1	1 - D 9
	66865	6680A -1	2 - J 9		16103	1600A -1	1 - C 5	SHEET, TUBE	26922	2610A -1	1 - F 8
	76761	6120A -1	2 - I 7		17335	1700A -1	1 - D 5	SHELL, CONNECTING	19565	1930A -1	1 - E 6
SCREW SET	17313	1720A -1	1 - G 5		17442	1700A -1	1 - D 5	SHIELD (L), SPLASH	56141	5310A -1	2 - G 4
	23371	1359A -1	1 - N 3		18216	1820A -1	1 - I 5	SHIELD (R), SPLASH	56131	5310A -1	2 - G 4
	24360	1820A -1	1 - I 5		19223	1910A -1	1 - N 5	SHIELD, HEAT	60715	6610A -1	2 - C 9
	24526	1830A -1	1 - J 5		19335	1920A -1	1 - C 6	SHIELD, SPLASH	56191	5310A -1	2 - G 4
	24535	1830A -1	1 - J 5		19442	1920A -1	1 - C 6	SHIM	18375	1800A -1	1 - H 5
	24725	1840A -1	1 - K 5		26154	2600A -1	1 - E 8	SHIM 'A' (L), HINGE	63231	6230A -1	2 - K 8
SCREW SET, IDLE ADJUST	23374	1360A -1	1 - C 4		27018	2700A -1	1 - H 8	SHIM 'A' (R), HINGE	62231	6230A -1	2 - K 8
SCREW SET, THROTTLE ADJUST	23440	1360A -2	1 - D 4		33065	3300A -1	1 - C 9	SHIM 'A', DAMPER	62636	6230A -1	2 - K 8
SCREW, ADJUST	23845	1400AA-1	1 - J 4	SEAL, PISTON	19384	1920A -1	1 - C 6	SHIM 'A', STRIKER	62366	6230A -1	2 - K 8
	23845	1400A -1	1 - I 4		19385	1920A -1	1 - C 6	SHIM 'B', DAMPER	62637	6230A -1	2 - K 8
	27301	2700A -2	1 - I 8		19603	1940A -1	1 - G 6	SHIM 'B', HINGE	62232	6230A -1	2 - K 8
	87014	5100A -1	2 - J 3	SEAL, PLATE-TOP		6152A -1	2 - H 8	SHIM 'B', STRIKER	62367	6230A -1	2 - K 8
SCREW, BLEEDER	33691	3300A -1	1 - C 9	SEAL, RADIATOR LOW	15208	1500AA-1	1 - M 4	SHIM 'C' (L), HINGE	63241	6230A -1	2 - K 8
	33691	2610AA-1	1 - G 8	SEAL, RADIATOR SIDE	15209	1500AA-1	1 - M 4	SHIM 'C' (R), HINGE	62241	6230A -1	2 - K 8
	33691	2610A -1	1 - F 8	SEAL, RING		6152A -1	2 - H 8	SHIM 'D', HINGE	62233	6230A -1	2 - K 8
	33691	4140A -1	1 - K 9			6152AB-1	2 - I 8	SHIM KIT, ADJUST	3214C	3210A -1	1 - M 8
SCREW, GARNISH	60702	5560A -1	2 - C 5	SEAL, SIDE	23151	1110A -1	1 - H 3	SHIM, ADJUST	14652	1400A -1	1 - I 4
SCREW, KNUCKLE	57109	5700AA-1	2 - C 6	SEAL, TOP PLATE		6152AC-1	2 - J 8		14652	1400AA-1	1 - J 4
	57109	5700A -1	2 - H 5			6152AB-1	2 - I 8		17207	1710A -1	1 - E 5
	88117	5700AA-3	2 - E 6	SEAL, WATER	15120	1500AA-1	1 - M 4		17287	1710A -1	1 - E 5
	88117	5700A -2	2 - I 5		15120	1500A -1	1 - K 4		17287	1710A -1	1 - E 5
SCREW, MACHINE		6132A -1	2 - J 7	SEALANT, SILICONE	23045	1040A -2	1 - F 3		17327	1710A -2	1 - F 5
		6132AB-1	2 - L 7	SEALER, UPPER	68173	6800A -2	2 - L10		17474	1720A -1	1 - G 5
SCREW, MIRROR	69112	6900A -1	2 - I11	SEALING KIT	49470	4140A -1	1 - K 9		32188	3210A -1	1 - M 8
	69123	6900A -1	2 - I11		49530	4140A -1	1 - K 9	SHIM, TILTING HINGE	51405	5103A -1	2 - K 3
SCREW, RUBBER	43608	4360A -1	1 - D10	SEAT (L), FRONT	57150	5700AA-1	2 - C 6	SHOE, BRAKE	26310	2610A -1	1 - F 8
SCREW, STOPPER	51411	5103A -1	2 - K 3	SEAT (R), FRONT	57100	5700AA-1	2 - C 6	SHUTTER	76426	6120A -1	2 - I 7
SCREW, TAPPING		6132AB-1	2 - L 7	SEAT, BOOT	68832	5570A -2	2 - F 5	SHUTTER NO. 1	76402	6110A -1	2 - G 7
		6132A -1	2 - J 7	SECTOR	44051	4400A -1	1 - F10	SHUTTER NO. 2	76403	6110A -1	2 - G 7
		6132AC-1	2 - C 8	SENSOR, OIL LEVEL	10730	6600A -1	2 - N 8	SHUTTER NO. 3	76404	6110A -1	2 - G 7
		6152AC-1	2 - J 8	SENSOR, THROTTLE	18910	6600A -1	2 - N 8	SILENCER, FLOOR	76071	6860A -2	2 - G11
		6152AC-1	2 - J 8	SENSOR, WATER LEVEL	15610	6600A -1	2 - N 8	SILENCER, MAIN	40500	4000A -1	1 - I 9
		6152AB-1	2 - I 8	SET PLATE, GLOVE LID	64050	5560A -2	2 - D 5	SLEEVE	19455	1950A -1	1 - H 6
		6152AB-1	2 - I 8	SET, CUP	32984	3200A -1	1 - L 8	SLEEVE, BEARING	24715	1840A -1	1 - K 5
		6152A -1	2 - H 8	SET-HORN	32750	3200A -1	1 - L 8		24741	1840A -2	1 - L 5
		6152A -1	2 - H 8	SET-SCREW	32740	3200A -1	1 - L 8	SLEEVE, CLUTCH HUB	17242	1710A -1	1 - E 5
	67568	6630A -1	2 - G 9	SHAFT	19670	1940A -1	1 - G 6		17732	1710A -2	1 - F 5
SEAL KIT		6142AC-1	2 - G 8		24740	1840A -2	1 - L 5	SLEEVE, SPEEDO GEAR	19442	1920A -1	1 - C 6
		6142A -1	2 - E 8	SHAFT, CLUTCH	76467	6120A -1	2 - I 7	SLEEVE, SPEEDOMETER	17442	1700A -1	1 - D 5
		6142AB-1	2 - F 8		76513	6110A -1	2 - G 7	SLIDE 'A' (L), BUMPER	50053	5000A -1	2 - D 3
	32180	3210A -1	1 - M 8	SHAFT, DIFFERENTIAL	24745	1840A -2	1 - L 5		50243	5010A -1	2 - F 3
	49240	3300A -1	1 - C 9	SHAFT, DIFFERENTIAL PINION	27261	2700A -2	1 - I 8	SLIDE 'A' (R), BUMPER	50043	5000A -1	2 - D 3
SEAL SET, DAMPER	34760	3400A -1	1 - D 9	SHAFT, DRIVEN GEAR	14620	1400AA-1	1 - J 4		50233	5010A -1	2 - F 3
SEAL SET, OIL	23180	1110A -1	1 - H 3		14620	1400A -1	1 - I 4	SLIDE 'B' (L), BUMPER	50052	5000A -1	2 - D 3
SEAL, AIR	15331	1500A -2	1 - L 4	SHAFT, ECCENTRIC	11400	1100A -1	1 - G 3		50052	5010A -1	2 - F 3
	15332	1500A -2	1 - L 4	SHAFT, INPUT	19678	1910A -1	1 - N 5	SLIDE 'B' (R), BUMPER	50042	5000A -1	2 - D 3
SEAL, AIR RING		6152AC-1	2 - J 8	SHAFT, MAIN	17221	1710A -1	1 - E 5	SOCKET	55261	5540A -1	2 - N 4
SEAL, APEX	11301	1110A -1	1 - H 3	SHAFT, MANUAL	19431	1950A -1	1 - H 6		55261	5540A -1	2 - N 4
SEAL CORNER	11321	1110A -1	1 - H 3	SHAFT, OIL PUMP	14112	1400A -1	1 - I 4	SOCKET & HOLDER	51354	6900A -1	2 - I11
SEAL, CUT RING	19258	1910A -1	1 - N 5		14112	1400AA-1	1 - J 4	SOLENOID	23327	1360A -1	1 - C 4
SEAL, DUST	19036	1950A -1	1 - H 6	SHAFT, PARKING PAWL	19731	1950A -1	1 - H 6	SOLENOID, DOWNSHIFT	19821	6600A -1	2 - N 8
	32279	3230A -1	1 - N 8	SHAFT, PROPELLER	25100	2500AA-1	1 - D 8	SPACER		6142A -1	2 - E 8
	32279	3230A -1	1 - N 8		25100	2500A -1	1 - C 8		11502	1100A -1	1 - G 3
	34565	3400A -1	1 - D 9	SHAFT, REAR AXLE	26111	2600A -1	1 - E 8		15103	1500AA-1	1 - M 4
SEAL, DUST-PITMAN	32278	3210A -1	1 - M 8	SHAFT, REVERSE IDLE GEAR	17315	1710A -2	1 - F 5		15103	1500A -1	1 - K 4
SEAL, KIT	49240	2610AA-1	1 - G 8	SHAFT, SECTOR	32141	3210A -1	1 - M 8		17304	1710A -2	1 - F 5
SEAL, LEATHER CUT	19394	1920A -1	1 - C 6	SHAFT, VALVE	13120	1300A -1	1 - I 3		27401	2700A -2	1 - I 8
	19476	1930A -1	1 - E 6								

ALPHABETICAL INDEX

PART NAME	D-CODE	SECTION	LOCATION	PART NAME	D-CODE	SECTION	LOCATION	PART NAME	D-CODE	SECTION	LOCATION
SPACER	34135	3410A	1-E 9	SPRING, CONTROL LEVER	76432	6120A	2-17	STUD, REACTOR	10105	1030A	1-D 3
	34384	3400A	1-D 9	SPRING, CORNER SEAL	11323	1110A	1-H 3	SUN VISOR (L)	69240	6900A	2-J11
	40073	4000A	1-19	SPRING, FRONT-INNER	11351	1110A	1-H 3	SUN VISOR (R)	69210	6900A	2-J11
	40074	4000A	1-19	SPRING, FRONT-OUTER	11353	1110A	1-H 3	SUNROOF	62820	6330A	2-M 8
	40076	4000A	1-19	SPRING, GOVERNOR	19666	1940A	1-G 6	SUPPORTER	18111	1800A	1-H 5
	43063	4300A	1-N 9	SPRING, HINGE	64466	5570A	2-F 5		18111	1800A	1-H 5
	43608	4360AA	1-E10	SPRING, LID-LAMP	51401	5103A	2-K 3		18114	1800A	1-H 5
	46084	4600A	1-H10	SPRING, METER HOOD	55412	5540A	2-N 4	SUPPORTER, ACTUATOR	19701	1950A	1-H 6
	67302	6730A	2-G10	SPRING, PAWL RETURN	19733	1950A	1-H 6	SWITCH	24760	1840A	2-L 5
	67436	6750A	2-110	SPRING, PELLET	14821	1500A	1-K 4		76447	6115A	2-H 7
	68861	6300A	2-L 8	SPRING, PISTON	19606	1940A	1-G 6	SWITCH, A.C.C.	66128	6611A	2-D 9
	76513	6115A	2-H 7	SPRING, PISTON RETURN	19363	1920A	1-C 6	SWITCH, BACK-UP LAMP	17640	6600A	2-N 8
SPACER 'A'	70447	6300A	2-L 8		19486	1930A	1-E 6	SWITCH, BI-METAL	66948	6680A	2-K 9
SPACER 'C'	70449	6300A	2-L 8	SPRING, REAR-INNER	11361	1110A	1-H 3	SWITCH, BUZZER	66156	0900A	2-C 3
SPACER, BEARING	15115	1500AA	1-M 4	SPRING, REAR-OUTER	11363	1110A	1-H 3	SWITCH, CLUTCH	18660	430GA	1-N 9
	26155	2600A	1-E 8	SPRING, RETURN	41081	4300A	1-N 9	SWITCH, COMBINATION	66110	6611A	2-D 9
SPACER, DOWEL	19734	1950A	1-H 6		41619	4160A	1-L 9	SWITCH, DOOR	66820	6620A	2-F 9
SPACER, HINGE-LOWER	58245	5830A	2-K 6		44352	4400A	1-F10	SWITCH, FUEL LID OPENER	66700	6610A	2-C 9
SPACER, HINGE-UPPER	58215	5830A	2-K 6		52672	5230A	2-F 4	SWITCH, GLOVE TRAY	60690	5560A	2-C 5
SPACER, MOUNTING		6142AB	2-F 8		52863	5230A	2-F 4	SWITCH, IGNITION	66155	090CA	2-C 3
		6142AC	2-G 8	SPRING, RETURN-LOWER	26342	2610A	1-F 8	SWITCH, INHIBITOR	19444	6600A	2-N 8
SPACER, MOUNTING RUBBER	45182	4500A	1-G10	SPRING, RETURN-UPPER	26341	2610A	1-F 8	SWITCH, KICK DOWN	18660	6620A	2-F 9
SPACER, OIL PIPE	13331	1910A	1-N 5	SPRING, SELECT	17465	1720A	1-G 5	SWITCH, LEVEL	76673	6720A	2-F10
SPACER, PULLEY	15211	1500A	1-K 4	SPRING, SIDE SEAL	11317	1110A	1-H 3	SWITCH, LIGHT & TURN	66122	6611A	2-D 9
	15211	1500AA	1-M 4	SPRING, SYNCHRONIZER KEY	17264	1710A	1-E 5	SWITCH, LOW-PRESSURE CUT-OFF		6132AC	2-C 8
SPACER, STABILIZER	28157	2810A	1-K 8		17724	1710A	2-F 5	SWITCH, MAIN	66340	6610A	2-C 9
	34158	3410A	1-E 9	STABILIZER	28101	2810A	1-K 8	SWITCH, MIRROR	69140	6900A	2-J11
SPEAKER, LOUD-FRONT	66960	6680A	2-K 9		34151	3410A	1-E 9	SWITCH, MOTOR ANTENNA	66800	6610A	2-C 9
SPEAKER, LOUD-REAR	66970	6680A	2-K 9	STARTER	18400	1840A	1-K 5	SWITCH, PARKING LAMP	66840	6620A	2-F 9
SPEEDOMETER	55471	5540A	2-N 4	STATOR	24501	1830A	1-J 5	SWITCH, POWER WINDOW	66350	6615A	2-E 9
SPINDLE, SELECT LOCK	17476	1720A	1-G 5	STAY (L) DAMPER	63610	6230A	2-K 8	SWITCH, REAR DEFROSTER	66460	6610A	2-C 9
SPOILER, FRONT	50881	5310A	2-G 4	STAY (L) FENDER	52250	5310A	2-G 4	SWITCH, REMOTE CONTROL	66630	6610A	2-C 9
SPOILER, REAR	51950	5180A	2-E 4	STAY (L) MIRROR		6900A	2-111	SWITCH, RETRACTOR	66670	6610A	2-C 9
SPRING	11412	1100A	1-G 3	STAY (R) DAMPER	62610	6230A	2-K 8	SWITCH, ROOM LAMP	60690	6230A	2-K 8
	13087	1350A	1-M 3	STAY (R) FENDER	52150	5310A	2-G 4	SWITCH, STOP	67210	4300A	1-N 9
	13087	6640A	2-19	STAY (R) MIRROR	69120	6900A	2-111	SWITCH, TEMPERATURE	18880	6600A	2-N 8
	14273	1040A	1-E 3	STAY, DAMPER	62610	6230A	2-K 8	SWITCH, THERMO	18890	6600A	2-N 8
	17411	1720A	1-G 5	STAY, GLOVE TRAY	64162	5560A	2-D 5		18890	6600A	2-N 8
	17411	1720A	1-G 5	STAY, HOOD	52510	5230A	2-F 4	SWITCH, THERMOSTAT-PRESET		6152AC	2-J 8
	17477	1720A	1-G 5	STEM, PISTON	19386	1920A	1-C 6	SWITCH, THERMOSTAT-PRESET FROSTING		6152A	2-H 8
	17483	1720A	1-G 5	STOPPER	41681	4160A	1-L 9			6152AB	2-L 8
	19247	1910A	1-N 5		64043	5560A	2-D 5	SWITCH, WIPER	66123	6611A	2-D 9
	19664	1940A	1-G 6	STOPPER SET	24712	1840A	1-K 5		67540	6610A	2-C 9
	44031	4400A	1-F10	STOPPER, BUMPER	28320	2800A	1-J 8				
	46038	4600A	1-H10	STOPPER, CONSOLE LID	64481	5570A	2-F 5	* * * * *			
	46062	4600A	1-H10	STOPPER, FILLER LID	42408	4200A	1-M 9	TACHOMETER	55461	5540A	2-N 4
	76135	6110A	2-G 7	STOPPER, RUBBER	69232	6900A	2-J11	TANK	67480	6750A	2-110
	76151	6120A	2-17	STOPPER, STEERING	34159	3400A	1-D 9		76671	6720A	2-F10
	76428	6110A	2-G 7	STRAINER	23304	1360A	1-C 4	TANK SET, RESERVE	41551	4140A	1-K 9
	76510	6115A	2-H 7	STRAINER, OIL	14240	1400A	1-14		43550	4340A	1-C10
SPRING (L), COIL		3400A	1-D 9		14240	1400AA	1-J 4	TANK, FUEL	42110	4200A	1-M 9
SPRING (R), COIL	34011	3400A	1-D 9	STRAP	15908	1580A	1-N 4	TANK, STARTING FLUID	13510	1350A	1-M 3
SPRING LIFT, LID	42431	4200A	1-M 9	STRAP 'A', CARGO ROOM	69570	6900A	2-J11	TANK, SUB	15350	1500A	2-14
SPRING SET	24308	1820A	1-15	STRAP 'B', CARGO ROOM	69580	6900A	2-K11		15350	1500AA	1-M 4
	24754	1840A	2-L 5	STRAP, AIR PUMP	13714	1371A	1-E 4	TANK, WASHER	67480	6720A	2-F10
SPRING SET, RETURN	23320	1360A	1-C 4	STRAP, ALTERNATOR	18361	1800A	1-H 5	TANK, WASHER-REAR WIPER	76671	6750A	2-110
SPRING, ADJUST	66016	5100A	2-J 3	STRIKER	58570	5830A	2-K 6	TERMINAL	32018	3200A	1-L 8
SPRING, APEX SEAL	11304	1110A	1-H 3		64101	5560A	2-D 5		67371	6700A	2-M 9
SPRING, BALL PARK	19703	1950A	1-H 6	STRIKER, LOCK	62361	6230A	2-K 8	TERMINAL SET	24590	1830A	1-J 5
SPRING, BOOT PANEL	55216	5570A	2-E 5	STRIKER, STORAGE BOX	64461	6900A	2-111	TERMINAL, PLATE	55232	6680A	2-J 9
SPRING, BRAKE BACK	26315	2610A	1-F 8	STRUT, BAND	19361	1920A	1-C 6	THERMO UNIT	13531	1350A	1-M 3
SPRING, BRAKE SHOE	26345	2610A	1-F 8	STUD	10208	1040A	1-E 3	THERMOSTAT	15171	1500A	1-K 4
SPRING, BRUSH	24521	1830A	1-J 5		13456	1310A	1-J 3		15171	1500AA	1-M 4
	24752	1840A	2-L 5		39382	3900A	1-H 9	TIRE	37600	3700A	1-F 9
SPRING, COIL	28010	2800A	1-J 3		40398	4000A	1-19	TOOL SET	68660	6870A	2-H11
SPRING, CONICAL	27259	2700A	2-18								

ALPHABETICAL INDEX

ALPHABETICAL INDEX

PART NAME	D-CODE	SECTION	LOCATION	PART NAME	D-CODE	SECTION	LOCATION	PART NAME	D-CODE	SECTION	LOCATION
TRANSMISSION, COMPLETE	19090	1910A -1	1 - N 5	VALVE SET, FLOAT	23390	1360A -1	1 - C 4		46019	4600A -1	1 - H10
TRAY, ASH	64620	5500A -2	2 - M 4	VALVE, AIR	37600	3700A -1	1 - F 9		76474	6120A -1	2 - I 7
TRAY, ASH-INNER	64640	5500A -2	2 - M 4	VALVE, AIR CONTROL	13720	1371A -1	1 - E 4		76475	6120A -1	2 - I 7
TRAY, BATTERY	56863	1850A -1	1 - M 5	VALVE, ALTITUDE COMPENSATOR	20770	1380AA-1	1 - H 4	WASHER, RUBBER	67301	6730A -1	2 - G10
TRAY, GLOVE	64161	5560A -2	2 - D 5		20770	1380A -1	1 - F 4	WASHER, SEAL	10455	1040A -1	1 - E 3
TRIM (L), CENTER PILLAR	68120	6800A -1	2 - K10	VALVE, ANTI-AFTERBURN	13750	1380AA-1	1 - H 4	WASHER, SPRING	13882	1310A -1	1 - J 3
TRIM (L), CTR. PILLAR	68241	6800A -2	2 - L10		13750	1380A -1	1 - F 4	WASHER, TAB	33043	3300A -1	1 - C 9
TRIM (L), DOOR		5840A -1	2 - C 7	VALVE, BRAKE PIPE	43900	4360AA-1	1 - E10	WASHER, THRUST	11507	1100A -1	1 - G 3
TRIM (L), FRONT SIDE	68391	6840A -1	2 - C11		43900	4360A -1	1 - D10		17276	1710A -1	1 - E 5
TRIM (L), FRT. PILLAR	68191	6800A -2	2 - L10	VALVE, CHECK	13270	1320A -1	1 - K 3		17313	1710A -2	1 - F 5
TRIM (L), QUARTER	68550	6840A -1	2 - C11		13730	1371A -1	1 - E 4		17313	1710A -2	1 - F 5
TRIM (L), REAR PILLAR	68330	6800A -2	2 - L10	VALVE, CONTROL	20730	4000A -1	1 - I 9	WASHER, THRUST LOCK	17631	1710A -2	1 - F 5
TRIM (L), SEAT BACK	88181	5700A -4	2 - K 5		42710	4200A -1	1 - M 9	WASHER, WAVE	17482	1720A -1	1 - G 5
	88181	5700AA-5	2 - G 6	VALVE, DELAY	19750	1920A -1	1 - C 6	WEATHERSTRIP (L), DOOR		5800A -1	2 - J 6
TRIM (L), SEAT CUSHION	88161	5700A -3	2 - J 5		13980	1380AA-1	1 - H 4	WEATHERSTRIP (R), DOOR	58760	5800A -1	2 - J 6
	88161	5700AA-4	2 - F 6	VALVE, EXPANSION	13980	1380A -1	1 - F 4	WEATHERSTRIP, HOOD	56787	5230A -1	2 - F 4
TRIM (L), TIRE HOUSE	68771	6840A -2	2 - D11	VALVE, EXPANSION-EXTENSION EQUALIZED		6152AC-1	2 - J 8	WEATHERSTRIP, INNER	58821	5840A -1	2 - C 7
TRIM (L), TRUNK SIDE	68870	6840A -2	2 - D11	VALVE, EXPANSION-EXTENSION EQUALIZER		6152A -1	2 - H 8	WEATHERSTRIP, OUTER	58811	5840A -1	2 - C 7
TRIM (R), CENTER PILLAR	68110	6800A -1	2 - K10	VALVE, FUEL VAPORIZER	42720	4200A -1	1 - M 9	WEATHERSTRIP, RR. WINDOW	63932	6300A -1	2 - L 8
TRIM (R), CTR. PILLAR	68221	6800A -2	2 - L10	VALVE, MAIN SWITCH	66422	6610A -1	2 - C 9	WEATHERSTRIP, TOP	62805	6330A -1	2 - M 8
TRIM (R), DOOR	68420	5840A -1	2 - C 7	VALVE, MANUAL	19768	1920A -1	1 - C 6	WEIGHT, BALANCE	11511	1100A -1	1 - G 3
TRIM (R), FRONT PILLAR	68171	6800A -1	2 - K10	VALVE, PURGE	20950	1380AA-1	1 - H 4	WEIGHT, BALANCING	37600	3700A -1	1 - F 9
TRIM (R), FRONT SIDE	68371	6840A -1	2 - C11		20950	1380A -1	1 - F 4	WEIGHT, CONTROL	11750	1100A -1	1 - G 3
TRIM (R), QUARTER	68520	6840A -1	2 - C11	VALVE, THREE-WAY	13240	1380AA-1	1 - H 4	WEIGHT, PUMP	23301	1360A -1	1 - C 4
TRIM (R), REAR PILLAR	68320	6800A -2	2 - L10		13240	1380A -1	1 - F 4	WELT, SEAMING	58755	5800A -1	2 - J 6
TRIM (R), SEAT BACK	88131	5700A -2	2 - I 5	VALVE, WATER	76416	6110A -1	2 - G 7		68911	6800A -3	2 - M10
	88131	5700AA-3	2 - E 6	VALVE-FUEL CUT	45160	4500A -1	1 - G10	WHEEL SET, DISC-ALUM.	37600	3700A -2	1 - G 9
TRIM (R), SEAT CUSHION	88111	5700A -1	2 - H 5					WHEEL, DISC	37600	3700A -1	1 - F 9
	88111	5700AA-2	2 - D 6					WHEEL, SPROCKET	14143	1400A -1	1 - I 4
TRIM (R), TIRE HOUSE	68761	6840A -2	2 - D11						14143	1400AA-1	1 - J 4
TRIM (R), TRUNK SIDE	68860	6840A -2	2 - D11					WIRE	13086	1250A -1	1 - M 3
TRIM, TRUNK END	68890	6840A -2	2 - D11						66944	6680A -2	2 - K 9
TUBE, ALUMINUM EXTENSION		6152AB-1	2 - I 8	WASHER	19055	1950A -1	1 - H 6	WIRE, A.C.C.	66311	6640A -1	2 - I 9
		6152A -1	2 - H 8		23366	1360A -1	1 - C 4	WIRE, ACCELERATOR	41660	4160A -1	1 - L 9
TUBE, EXTENSION		6152AC-1	2 - J 8		23408	1360A -2	1 - D 4	WIRE, CHOKE	60050	5500A -2	2 - M 4
TUBE, METERING OIL	14630	1400A -1	1 - I 4		27012	2700A -1	1 - H 8	WIRE, CONNECTOR		6152AC-1	2 - J 8
	14630	1400AA-1	1 - J 4		27252	2700A -1	1 - H 8	WIRE, HEATER CONTROL	76521	6115A -1	2 - H 7
	14640	1400A -1	1 - I 4		32341	3230A -1	1 - N 8		76522	6115A -1	2 - H 7
	14640	1400AA-1	1 - J 4		34158	2800A -1	1 - J 8		76523	6115A -1	2 - H 7
TUBE, OIL LEVEL	19870	1920A -2	1 - D 6		39383	3900A -1	1 - H 9	WIRE, HIGH TENSION	18110	1800A -1	1 - H 5
TUBE, VACUUM	13750	1380A -1	1 - F 4		39386	3900A -1	1 - H 9		18120	1800A -1	1 - H 5
	13778	1380A 1	1 - F 4		40166	4000A -1	1 - I 9		18130	1800A -1	1 - H 5
	18200	1800A -1	1 - H 5		40815	4000A -2	1 - J 9		18140	1800A -1	1 - H 5
TUBE, VENT	42313	4200A -1	1 - M 9		62636	6750A -1	2 - I10		18150	1800A -1	1 - H 5
TY-RAP		6132A -1	2 - I 7		76022	6120A -1	2 - I 7		18160	1800A -1	1 - H 5
		6132AC-1	2 - C 8		76433	6110A -1	2 - G 7		18170	1800A -1	1 - H 5
		6132AB-1	2 - L 7		76473	6115A -1	2 - H 7		18180	1800A -1	1 - H 5
					76516	6115A -1	2 - H 7	WIRE, JUMPER		6152AB-1	2 - I 8
					76621	6750A -1	2 - I10			6152A -1	2 - H 8
					87132	6750A -1	2 - I10	WIRE, RADIO-EARTH	67861	6680A -3	2 - L 9
UNIT, CENTRAL PROCESSING	67560	6630A -1	2 - G 9		88106	5700A -1	2 - H 5	WIRE, RELEASE-HOOD	56710	5230A -1	2 - F 4
UNIT, HEAT GAUGE	18510	6600A -1	2 - N 8		88106	5700AA-2	2 - D 6	WIRING, BLOWER	76467	6120A -1	2 - I 7
UNIT, WATER LEVEL SENSOR	15620	6600A -1	2 - N 8	WASHER & SCREW	76432	6110A -1	2 - G 7	WIRING, ENGINE	18050	6701A -1	2 - N 9
				WASHER SET	24726	1840A -1	1 - K 5	WRENCH, HUB NUT	68070	6870A -1	2 - H11
				WASHER, ADJUST	17641	1710A -2	1 - F 5				
					66821	6620A -1	2 - F 9				
V-BELT	13715	1371A -1	1 - E 4	WASHER, CAP	67375	6730A -1	2 - G10				
	15906	1580A -1	1 - N 4	WASHER, CUP	76606	6730A -1	2 - G10				
	16381	1800A -1	1 - H 5	WASHER, FRONT CLUTCH	19641	1930A -2	1 - F 6	YOKE	24701	1840A -1	1 - K 5
VACUUM POWER ASSIST	43800	4340A -1	1 - C10	WASHER, LOCK	18056	6701A -1	2 - N 9		25130	2500A -1	1 - C 8
VACUUM SET	24350	1820A -1	1 - I 5		20548	4000A -1	1 - I 9	YOKE, STATER	76614	6760A -1	2 - J10
	24351	1820A -1	1 - I 5	WASHER, PLAIN	19337	1920A -1	1 - C 6	YOKE, STATOR	87922	6740A -1	2 - H10
VALVE	13121	1300A -1	1 - I 3		19388	1920A -1	1 - C 6	YOKE, UNIVERSAL JOINT	25021	2500A -1	1 - C 8
	19663	1940A -1	1 - G 6		19739	1920A -1	1 - C 6				
	19665	1940A -1	1 - G 6		40077	4000A -1	1 - I 9				
VALVE PLATE ASSEMBLY		6142AB-1	2 - F 8								
		6142A -1	2 - E 8								

PART NUMBER INDEX

PART NUMBER INDEX

This index is listed in the following sequence.

GENERAL PARTS

EXAMPLE

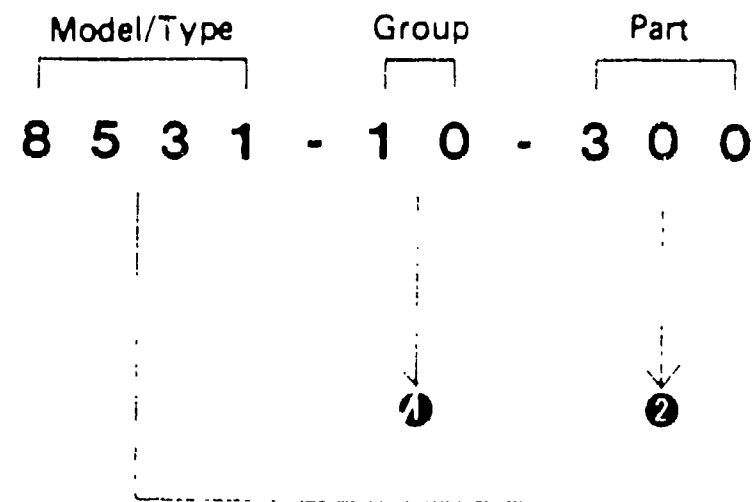

- ① first, in the sequence of group (5th & 6th digits)
- ② second, in the sequence of part (7th-9th digits)
- ③ third, in the sequence of model/type (1st-4th digits)

STANDARD PARTS

Standard Parts are listed in numerical sequence after General Parts.
(Note: Those parts which do not have D-Code are not listed in the index.)

PART NUMBER INDEX

PART NUMBER	SECTION	LOCATION	PART NUMBER	SECTION	LOCATION	PART NUMBER	SECTION	LOCATION	PART NUMBER	SECTION	LOCATION	PART NUMBER	SECTION	LOCATION
9994-00-600	5103A -1	2 - K 3	N225-10-861	1040A -1	1 - E 3	1202-11-343	1110A -1	1 - H 3	8871-13-085B	1350A -1	1 - M 3	1480-13-370	1310A -1	1 - J 3
9951-01-000	1720A -1	1 - G 5	8871-10-862	1040A -1	1 - E 3	1011-11-351	1110A -1	1 - H 3	N229-13-085	1350A -1	1 - M 3	1480-13-380A	1310A -1	1 - J 3
9970-03-060T	5120A -1	2 - N 3	9954-10-0901	1950A -1	1 - H 6	N225-11-351	1110A -1	1 - H 3	8871-13-086B	1350A -1	1 - M 3	3565-13-390	1310A -1	1 - J 3
9965-04-4050	3700A -1	1 - F 9	9954-10-1101	1100A -1	1 - G 3	1011-11-353A	1110A -1	1 - H 3	N225-13-086A	1350A -1	1 - M 3	8871-13-400B	1320A -1	1 - K 3
FA01-09-0108	0900A -1	2 - C 3	9954-10-1201	1950A -1	1 - H 6	1011-11-361	1110A -1	1 - H 3	8871-13-087A	1350A -1	1 - M 3	N249-13-400B	1320A -1	1 - K 3
N201-10-100	1030A -1	1 - D 3	9954-10-1601	1400A -1	1 - I 4	N225-11-361	1110A -1	1 - H 3	8871-13-087A	6640A -1	2 - I 9	8871-13-407	1320A -1	1 - K 3
0839-10-105	1030A -1	1 - D 3	9954-10-1601	1400AA-1	1 - J 4	1011-11-363A	1110A -1	1 - H 3	N201-13-100A	1300A -1	1 - I 3	1480-13-445	1320A -1	1 - K 3
0839-10-111B	1030A -1	1 - D 3	9954-10-1601	1920A -2	1 - D 6	1883-11-400A	1100A -1	1 - G 3	1010-13-104	1380A -1	1 - F 4	N201-13-445	1320A -1	1 - K 3
1757-10-171A	1030A -1	1 - D 3	9935-10-1999	1380A -1	1 - F 4	9938-11-400	1500A -1	1 - K 3	1010-13-104	1380AA-1	1 - H 4	0222-13-470B	1320A -1	1 - K 3
1480-10-172	1030A -1	1 - D 3	9954-10-3501	1800A -1	1 - H 5	9951-11-400	1040A -1	1 - E 3	1881-13-111A	1300A -1	1 - I 3	E508-13-470	1320A -1	1 - K 3
N231-10-173	1030A -1	1 - D 3	9935-10-4095	1380A -1	1 - F 4	N201-11-400	1100A -1	1 - G 3	8527-13-113	1300A -1	1 - I 3	0381-13-481	1320A -1	1 - K 3
N231-10-174	1040A -1	1 - E 3	9935-10-4095	1380AA-1	1 - H 4	1881-11-404	1100A -1	1 - G 3	1480-13-120A	1300A -1	1 - I 3	E508-13-481	1320A -1	1 - K 3
8981-10-200	1040A -1	1 - E 3	9935-10-4095	6640A -1	2 - I 9	0813-11-405	1100A -1	1 - G 3	N201-13-121	1300A -1	1 - I 3	1881-13-510G	1350A -1	1 - M 3
8981-10-200B	1040A -1	1 - E 3	9935-10-4999	1320A -1	1 - K 3	0839-11-411A	1100A -1	1 - G 3	1480-13-129	1300A -1	1 - I 3	1757-13-515A	1350A -1	1 - M 3
0839-10-203	1040A -1	1 - E 3	9935-10-4999	1380A -1	1 - F 4	0839-11-412	1100A -1	1 - G 3	1480-13-130A	1380A -1	1 - F 4	8871-13-527	1350A -1	1 - M 3
8562-10-205	1040A -1	1 - E 3	9935-10-4999	1380A -1	1 - F 4	9961-11-500	1710A -2	1 - F 5	1480-13-130A	1380AA-1	1 - H 4	8712-13-531	1350A -1	1 - M 3
1757-10-206A	1040A -1	1 - E 3	9935-10-4999	1380A -1	1 - F 4	9961-11-500	1940A -1	1 - G 6	N201-13-135	1380A -1	1 - F 4	1480-13-600B	1310A -1	1 - J 3
1757-10-207A	1040A -1	1 - E 3	9935-10-4999	1380AA-1	1 - H 4	9961-11-500	2610A -1	1 - F 8	N201-13-135	1380AA-1	1 - H 4	1480-13-621	1310A -1	1 - J 3
1757-10-208	1040A -1	1 - E 3	9935-10-4999	1800A -1	1 - H 5	9961-11-500	4140A -1	1 - K 9	N203-13-135	1380A -1	1 - F 4	1480-13-621	4000A -2	1 - J 9
8871-10-250A	1030A -1	1 - D 3	9935-10-6999	1380A -1	1 - F 4	1011-11-501	1100A -1	1 - G 3	N203-13-135	1380AA-1	1 - H 4	N201-13-650A	1380A -1	1 - F 4
8871-10-252	1030A -1	1 - D 3	9935-10-6999	1380AA-1	1 - H 4	0839-11-502	1100A -1	1 - G 3	1480-13-137A	1380A -1	1 - F 4	N231-13-650C	1380AA-1	1 - H 4
N201-10-300A	1040A -1	1 - E 3	9935-10-6999	4200A -1	1 - M 9	1011-11-504	1100A -1	1 - G 3	1480-13-137A	1380AA-1	1 - H 4	1757-13-710B	1371A -1	1 - E 4
N231-10-300A	1040A -1	1 - E 3	9935-10-6999	4200A -1	1 - M 9	0813-11-505B	1100A -1	1 - G 3	1480-13-139B	1380A -1	1 - F 4	1757-13-714	1371A -1	1 - E 4
1480-10-305	1040A -1	1 - E 3	9935-10-8999	1320A -1	1 - K 3	0839-11-506	1100A -1	1 - G 3	1480-13-139B	1380AA-1	1 - H 4	1757-13-715	1371A -1	1 - E 4
1481-10-305	1040A -1	1 - E 3	9935-10-8999	1320A -1	1 - K 3	1011-11-507	1100A -1	1 - G 3	N201-13-200A	1359A -1	1 - N 3	1757-13-717	1371A -1	1 - E 4
1757-10-309	1040A -1	1 - E 3	9935-10-8999	1320A -1	1 - K 3	0839-11-508	1100A -1	1 - G 3	N202-13-200A	1359A -1	1 - N 3	1480-13-718A	1371A -1	1 - E 4
1757-10-309	1040A -1	1 - E 3	9935-10-8999	1380A -1	1 - F 4	0839-11-509	1100A -1	1 - G 3	N203-13-200A	1359A -1	1 - N 3	N201-13-720	1371A -1	1 - E 4
0866-10-320A	1040A -1	1 - E 3	9935-10-8999	1380A -1	1 - F 4	1881-11-511	1100A -1	1 - G 3	N204-13-200A	1359A -1	1 - N 3	N203-13-720	1371A -1	1 - E 4
1758-10-351	1040A -1	1 - E 3	9935-10-8999	1380AA-1	1 - H 4	N201-11-511	1100A -1	1 - G 3	N231-13-200A	1359A -1	1 - N 3	N231-13-720	1371A -1	1 - E 4
N231-10-351A	1040A -1	1 - E 3	9997-11-000	1310A -1	1 - J 3	N226-11-511A	1100A -1	1 - G 3	N232-13-200A	1359A -1	1 - N 3	N201-13-724	1371A -1	1 - E 4
8341-10-400	1030A -1	1 - D 3	9997-11-000	6142A -1	2 - E 8	8519-11-517	1100A -1	1 - G 3	N233-13-200A	1359A -1	1 - N 3	N201-13-725	1371A -1	1 - E 4
HE03-10-404	1040A -1	1 - E 3	0000-11-001	6700A -1	2 - M 9	0839-11-531	1100A -1	1 - G 3	N234-13-200A	1359A -1	1 - N 3	1480-13-726	1371A -1	1 - E 4
3565-10-410A	1030A -1	1 - D 3	0000-11-002	6700A -1	2 - M 9	0839-11-551A	1100A -1	1 - G 3	8871-13-201A	1320A -1	1 - K 3	1480-13-727A	1380A -1	1 - F 4
8562-10-417	1030A -1	1 - D 3	0000-11-003	6700A -1	2 - M 9	8649-11-600	1100A -1	1 - G 3	1481-13-205C	1320A -1	1 - K 3	1480-13-727A	1380AA-1	1 - H 4
1015-10-451A	1040A -1	1 - E 3	0000-11-0015	6700A -1	2 - M 9	0820-11-611B	1100A -1	1 - G 3	N201-13-205	1359A -1	1 - N 3	1480-13-730	1371A -1	1 - E 4
1015-10-452A	1040A -1	1 - E 3	0000-11-0074	5500A -1	2 - L 4	N201-11-700	1100A -1	1 - G 3	8341-13-215	1360A -2	1 - D 4	N201-13-750	1370A -1	1 - F 4
0839-10-455	1040A -1	1 - E 3	0000-11-0074	5540A -1	2 - N 4	N231-11-700A	1100A -1	1 - G 3	1480-13-220B	1320A -1	1 - K 3	N201-13-750	1380AA-1	1 - H 4
3743-10-500	1030A -1	1 - D 3	1011-11-111	1110A -1	1 - H 3	0866-11-702	1100A -1	1 - G 3	1481-13-240A	1380A -1	1 - F 4	N201-13-755	1380A -1	1 - F 4
0820-10-502B	1030A -1	1 - D 3	0000-11-0194	5105A -1	2 - L 3	0820-11-705	1100A -1	1 - G 3	1481-13-240A	1380AA-1	1 - H 4	N201-13-755	1380AA-1	1 - H 4
3743-10-550A	1030A -1	1 - D 3	0000-11-0194	5120A -1	2 - N 3	0810-11-711	1100A -1	1 - G 3	1482-13-240A	1380A -1	1 - F 4	N201-13-756	1380A -1	1 - F 4
0813-10-555A	1030A -1	1 - D 3	0000-11-0194	5500A -1	2 - L 4	1883-11-751A	1100A -1	1 - G 3	1480-13-241A	1380A -1	1 - F 4	N201-13-756	1380AA-1	1 - H 4
1668-10-556A	1030A -1	1 - D 3	0000-11-0194	5540A -1	2 - N 4	N226-11-751A	1100A -1	1 - G 3	N225-13-241A	1380AA-1	1 - H 4	N201-13-757A	1380A -1	1 - F 4
1480-10-600A	1040A -1	1 - E 3	0000-11-0194	5560A -1	2 - C 5	N326-11-D03	1100A -1	1 - G 3	3648-13-270A	1320A -1	1 - K 3	N201-13-757A	1380AA-1	1 - H 4
0820-10-605	1040A -1	1 - E 3	0000-11-0194	5570A -1	2 - E 5	0000-11-1156	5110A -1	2 - M 3	3648-13-290	1380A -1	1 - F 4	0107-13-781	1360A -1	1 - C 4
1757-10-609	1040A -1	1 - E 3	0000-11-0194	6900A -2	2 - J11	0000-11-1157	5105A -1	2 - L 3	3648-13-290	1380AA-1	1 - H 4	8871-13-785C	1320A -1	1 - K 3
8871-10-631A	1040A -1	1 - E 3	0000-11-0293	6610A -1	2 - C 9	0000-11-1157	5110A -1	2 - M 3	8871-13-291A	1380A -1	1 - F 4	1757-13-857	1310A -1	1 - J 3
8527-10-641	1040A -1	1 - E 3	N201-11-300A	1110A -1	1 - H 3	0000-11-3022	5125A -1	2 - C 4	8871-13-291A	1380AA-1	1 - H 4	2329-13-876	1310A -1	1 - J 3
N201-10-700A	1040A -1	1 - E 3	N201-11-302A	1110A -1	1 - H 3	0000-11-3175	6900A -2	2 - J11	8871-13-296B	1380A -1	1 - F 4	1480-13-889A	1310A -1	1 - J 3
N203-10-700	1040A -1	1 - E 3	1011-11-304B	1110A -1	1 - H 3	0000-11-6014	5100A -1	2 - J 3	8871-13-296B	1380AA-1	1 - H 4	1700-13-945A	6640A -1	2 - I 9
0839-10-711	1040A -1	1 - E 3	0820-11-317	1110A -1	1 - H 3	0000-11-6024-HL	5100A -1	2 - J 3	N201-13-300	1330A -1	1 - L 3	N201-13-980A	1380A -1	1 - F 4
N201-10-730	6600A -1	2 - N 8	1202-11-321	1110A -1	1 - H 3	9961-12-000	1100A -1	1 - G 3	8871-13-305	5340A -1	2 - I 4	N231-13-980	1380AA-1	1 - H 4
N231-10-735	1040A -1	1 - E 3	N225-11-321	1110A -1	1 - H 3	9961-12-500	1720A -1	1 - G 5	1480-13-330	1310A -1	1 - J 3	8501-14-100	1400A -1	1 - I 4
9938-10-806	1910A -1	1 - N 5	N201-11-322	1110A -1	1 - H 3	9961-12-750	1950A -1	1 - H 6	2850-13-331	1910A -1	1 - N 5	8553-14-100	1400AA-1	1 - J 4
N201-10-830	1030A -1	1 - D 3	1202-11-323A	1110A -1	1 - H 3	N229-13-081	1350A -1	1 - M 3	8871-13-341A	1330A -1	1 - L 3	8501-14-110	1400A -1	1 - I 4
8555-10-845	1040A -1	1 - E 3	0820-11-341	1110A -1	1 - H 3	8341-13-085	1350A -1	1 - M 3	1757-13-351A	1330A -1	1 - L 3	8553-14-110	1400AA-1	1 - J 4

PART NUMBER INDEX

PART NUMBER	SECTION	LOCATION	PART NUMBER	SECTION	LOCATION	PART NUMBER	SECTION	LOCATION	PART NUMBER	SECTION	LOCATION	PART NUMBER	SECTION	LOCATION
1757-14-112	1400A -1	1 - I 4	1011-14-720	1500A -1	1 - K 4	1128-15-312A	1500A -2	1 - L 4	M501-17-245	1710A -2	1 - F 5	M503-17-411	1720A -1	1 - G 5
8553-14-112	1400AA-1	1 - J 4	N231-14-720B	1400AA-1	1 - J 4	1757-15-312	6680A -1	2 - J 9	M501-17-251	1710A -1	1 - E 5	M501-17-412	1720A -1	1 - G 5
0810-14-113	1400A -1	1 - I 4	8871-14-730	1500A -1	1 - K 4	8871-15-312	1500A -2	1 - L 4	M508-17-261A	1710A -1	1 - E 5	M502-17-421A	1720A -1	1 - G 5
0810-14-113	1400AA-1	1 - J 4	8871-14-742	1500A -1	1 - K 4	8871-15-331	1500A -2	1 - L 4	M509-17-261A	1710A -1	1 - E 5	M503-17-421	1720A -1	1 - G 5
0839-14-115	1040A -2	1 - F 3	N231-14-744B	1400AA-1	1 - J 4	N231-15-331A	1500AA-1	1 - M 4	M510-17-261	1710A -2	1 - F 5	M501-17-422	1720A -1	1 - G 5
0839-14-117	1400A -1	1 - I 4	0839-14-745A	1500A -1	1 - K 4	8871-15-332	1500A -2	1 - L 4	F401-17-264A	1710A -1	1 - E 5	M505-17-431A	1720A -1	1 - G 5
0839-14-117	1400AA-1	1 - J 4	N231-14-745B	1400AA-1	1 - J 4	N231-15-332A	1500AA-1	1 - M 4	F402-17-264	1710A -1	1 - E 5	M501-17-432	1720A -1	1 - G 5
8501-14-118	1400A -1	1 - I 4	N231-14-746	1400AA-1	1 - J 4	1052-15-350B	1500A -2	1 - L 4	F401-17-265A	1710A -1	1 - E 5	8057-17-441C	1700A -1	1 - D 5
8553-14-118	1400AA-1	1 - J 4	8871-14-810	1500A -1	1 - K 4	1052-15-350B	1500AA-1	1 - M 4	M501-17-271	1710A -1	1 - E 5	8057-17-441C	1920A -1	1 - C 6
0839-14-119B	1400A -1	1 - I 4	N201-14-820	6600A -1	2 - N 8	8871-15-351A	1500A -2	1 - L 4	0259-17-274A	1710A -1	1 - E 5	8562-17-441A	1920A -1	1 - C 6
0839-14-119B	1400AA-1	1 - J 4	1757-14-821	1500A -1	1 - K 4	8871-15-351A	1500AA-1	1 - M 4	8540-17-275A	1710A -1	1 - E 5	1011-17-442A	1700A -1	1 - D 5
8553-14-125	1400A -1	1 - I 4	1757-14-822	1500A -1	1 - K 4	1052-15-355A	1500A -2	1 - L 4	0259-17-276	1710A -1	1 - E 5	1011-17-442A	1920A -1	1 - C 6
8553-14-125	1400AA-1	1 - J 4	8872-15-010I	1500AA-1	1 - M 4	1052-15-355A	1500AA-1	1 - M 4	0259-17-277	1710A -1	1 - E 5	1011-17-443	1700A -1	1 - D 5
0839-14-141A	1400A -1	1 - I 4	8872-15-103	1500A -1	1 - K 4	8871-15-401A	1500A -1	1 - K 4	0259-17-278	1710A -1	1 - E 5	1011-17-443	1920A -1	1 - C 6
0839-14-141A	1400AA-1	1 - J 4	8872-15-103	1500AA-1	1 - M 4	N231-15-401B	1500AA-1	1 - M 4	0259-17-279	1710A -1	1 - E 5	M501-17-450	1720A -1	1 - G 5
0839-14-142	1400A -1	1 - I 4	1757-15-105A	1500A -1	1 - K 4	8871-15-511	1500A -1	1 - K 4	M501-17-281B	1710A -1	1 - E 5	M501-17-461A	1720A -1	1 - G 5
0839-14-142	1400AA-1	1 - J 4	1757-15-105A	1500AA-1	1 - M 4	N231-15-511	1500AA-1	1 - M 4	4069-17-283A	1710A -1	1 - E 5	M501-17-465B	1720A -1	1 - G 5
8871-14-160	1400A -1	1 - I 4	1757-15-106	1500A -1	1 - K 4	8871-15-521	1500A -1	1 - K 4	4069-17-284E	1710A -1	1 - E 5	M501-17-470A	1720A -1	1 - G 5
8871-14-160	1400AA-1	1 - J 4	1757-15-106	1500AA-1	1 - M 4	N231-15-521C	1500AA-1	1 - M 4	0419-17-288	1710A -1	1 - E 5	M501-17-474	1720A -1	1 - G 5
0810-14-171A	1400A -1	1 - I 4	1757-15-114	1500A -1	1 - K 4	N231-15-530A	1500AA-1	1 - M 4	0419-17-291	1710A -1	1 - E 5	M501-17-475	1720A -1	1 - G 5
0810-14-171A	1400AA-1	1 - J 4	1757-15-114	1500AA-1	1 - M 4	N231-15-540B	1500AA-1	1 - M 4	0419-17-292	1710A -1	1 - E 5	M502-17-476A	1720A -1	1 - G 5
3648-14-250	1400A -1	1 - I 4	1757-15-115B	1500AA-1	1 - M 4	N231-15-545	6100A -1	2 - F 7	0419-17-293	1710A -1	1 - E 5	M501-17-477	1720A -1	1 - G 5
3648-14-250	1400AA-1	1 - J 4	1757-15-118	1500A -1	1 - K 4	N231-15-545A	1500AA-1	1 - M 4	M502-17-295C	1710A -1	1 - E 5	M501-17-480A	1720A -1	1 - G 5
0839-14-273A	1040A -1	1 - E 3	1757-15-118A	1500AA-1	1 - M 4	N231-15-550	1500AA-1	1 - M 4	0821-17-297	1710A -1	1 - E 5	0303-17-482	1720A -1	1 - G 5
N231-14-273	1040A -2	1 - F 3	1757-15-120A	1500A -1	1 - K 4	N231-15-550	6100A -1	2 - F 7	8086-17-297	1710A -1	1 - E 5	M503-17-482A	1720A -1	1 - G 5
0839-14-274	1040A -2	1 - F 3	1757-15-120A	1500AA-1	1 - M 4	8553-15-610B	6600A -1	2 - N 8	M502-17-297A	1710A -2	1 - F 5	0824-17-483	1720A -1	1 - G 5
0730-14-296	1400A -1	1 - I 4	8871-15-121A	1500A -1	1 - K 4	8553-15-611	6600A -1	2 - N 8	M502-17-298A	1710A -1	1 - E 5	M501-17-486A	1720A -1	1 - G 5
0730-14-296	1400AA-1	1 - J 4	8871-15-121A	1500AA-1	1 - M 4	8248-15-620	6600A -1	2 - N 8	M502-17-299A	1710A -1	1 - E 5	M501-17-490B	1700A -1	1 - D 5
86Y1-14-302	1400A -1	1 - I 4	0118-15-125	1500A -1	1 - K 4	8562-15-908	1580A -1	1 - N 4	M501-17-301B	1710A -1	1 - E 5	0183-17-491	1720A -1	1 - G 5
N3Y6-14-302	1400A -1	1 - I 4	N201-15-125A	1500A -1	1 - K 4	8562-15-921	1580A -1	1 - N 4	8086-17-302C	1710A -1	1 - E 5	M501-17-510E	1720A -1	1 - G 5
N3Y6-14-302	1400AA-1	1 - J 4	N201-15-125A	1500AA-1	1 - M 4	0603-16-102B	1600A -1	1 - C 5	8086-17-304A	1710A -2	1 - F 5	M501-17-520	1720A -1	1 - G 5
8341-14-310	1400A -1	1 - I 4	1757-15-132	1500A -1	1 - K 4	0603-16-103	1600A -1	1 - C 5	M504-17-304	1710A -2	1 - F 5	M501-17-520 00	1720A -1	1 - G 5
1757-14-600	1400A -1	1 - I 4	1757-15-132	1500AA-1	1 - M 4	3975-16-214A	1600A -1	1 - C 5	0839-17-305B	1710A -2	1 - F 5	M501-17-524	1720A -1	1 - G 5
1757-14-600	1400AA-1	1 - J 4	1757-15-151B	1500A -1	1 - K 4	8540-16-220A	1600A -1	1 - C 5	M501-17-308A	1710A -2	1 - F 5	0884-17-530	1700A -1	1 - D 5
1757-14-611	1400A -1	1 - I 4	1757-15-151B	1500AA-1	1 - M 4	8540-16-220D	1600A -1	1 - C 5	8086-17-310B	1710A -2	1 - F 5	M501-17-550A	1700A -1	1 - D 5
1757-14-611	1400AA-1	1 - J 4	1757-15-152B	1500AA-1	1 - M 4	8540-16-225	1600A -1	1 - C 5	8086-17-310C	1710A -2	1 - F 5	M501-17-611B	1710A -2	1 - F 5
0820-14-620A	1400A -1	1 - I 4	8872-15-170A	1500A -1	1 - K 4	8540-16-241A	1600A -1	1 - C 5	0118-17-313B	1720A -1	1 - G 5	3648-17-626	1710A -2	1 - F 5
0820-14-620A	1400AA-1	1 - J 4	8872-15-170A	1500AA-1	1 - M 4	1769-16-410A	1600A -1	1 - C 5	M501-17-313	1710A -2	1 - F 5	8601-17-629	1710A -2	1 - F 5
0813-14-623	1400A -1	1 - I 4	1757-15-173	1500A -1	1 - K 4	N203-16-410A	1600A -1	1 - C 5	4077-17-314A	1710A -2	1 - F 5	0884-17-632A	1710A -2	1 - F 5
0813-14-623	1400AA-1	1 - J 4	1757-15-173	1500AA-1	1 - M 4	0839-16-432	1600A -1	1 - C 5	4077-17-315A	1710A -2	1 - F 5	0884-17-633A	1710A -2	1 - F 5
0820-14-625A	1400A -1	1 - I 4	3648-15-200A	1500A -1	1 - K 4	0862-16-460F	1600A -1	1 - C 5	4077-17-316	1710A -2	1 - F 5	0884-17-634A	1710A -2	1 - F 5
0820-14-625A	1400AA-1	1 - J 4	3648-15-200A	1500AA-1	1 - M 4	N203-16-460B	1600A -1	1 - C 5	8086-17-326	1700A -1	1 - D 5	0884-17-635A	1710A -2	1 - F 5
8871-14-651	1400A -1	1 - I 4	8871-15-205	1500A -1	1 - K 4	H606-16-510A	1600A -1	1 - C 5	0305-17-327	1710A -2	1 - F 5	1391-17-640	6600A -1	2 - N 8
N225-14-651	1400AA-1	1 - J 4	8871-15-205	1500AA-1	1 - M 4	8540-16-520A	1600A -1	1 - C 5	0305-17-328	1710A -2	1 - F 5	0862-17-641A	1710A -2	1 - F 5
1757-14-652	1400A -1	1 - I 4	St01-15-205	1500AA-1	1 - M 4	M503-17-100A	1700A -1	1 - D 5	M501-17-330B	1700A -1	1 - D 5	0862-17-642A	1710A -2	1 - F 5
1757-14-652	1400AA-1	1 - J 4	N201-15-210B	1500A -1	1 - K 4	0810-17-121	1700A -1	1 - D 5	0437-17-335A	1700A -1	1 - D 5	0862-17-643A	1710A -2	1 - F 5
8871-14-660B	1400A -1	1 - I 4	N201-15-210B	1500AA-1	1 - M 4	8086-17-140A	1710A -2	1 - F 5	0437-17-335A	1920A -1	1 - C 6	0862-17-644A	1710A -2	1 - F 5
8871-14-660B	1400AA-1	1 - J 4	8872-15-211	1500A -1	1 - K 4	M501-17-201A	1710A -1	1 - E 5	3728-17-341A	1710A -2	1 - F 5	W501-17-724	1710A -2	1 - F 5
3565-14-662A	1500A -1	1 - K 4	8872-15-211	1500AA-1	1 - M 4	M503-17-204	1710A -1	1 - E 5	3728-17-341A	1940A -1	1 - G 6	W501-17-725A	1710A -2	1 - F 5
3565-14-662A	1500AA-1	1 - M 4	N201-15-250B	1500A -1	1 - K 4	0249-17-210B	1710A -1	1 - E 5	0114-17-351	1720A -1	1 - G 5	W501-17-732A	1710A -2	1 - F 5
8871-14-670B	1400A -1	1 - I 4	N201-15-250B	1500AA-1	1 - M 4	M502-17-221	1710A -1	1 - E 5	M501-17-402B	1720A -1	1 - G 5	N201-18-050A	6701A -1	2 - N 9
8871-14-670B	1400AA-1	1 - J 4	N201-15-310B	1500A -1	1 - K 4	0317-17-225	1710A -1	1 - E 5	M501-17-404B	1720A -1	1 - G 5	N231-18-050B	6701A -1	2 - N 9
8871-14-700A	1500A -1	1 - K 4	N202-15-310B	1500A -1	1 - K 4	M501-17-231	1710A -1	1 - E 5	M501-17-406A	1720A -1	1 - G 5	834 -18-055	6701A -1	2 - N 9
N231-14-700C	1400AA-1	1 - J 4	N232-15-310A	1500AA-1	1 - M 4	F401-17-242A	1710A -1	1 - E 5	0014-17-411	1720A -1	1 - G 5	8872-18-056	6701A -1	2 - N 9
0813-14-716	1500A -1	1 - K 4	N249-15-310	1500AA-1	1 - M 4	F401-17-243A	1710A -1	1 - E 5	0103-17-411	1720A -1	1 - G 5	0000-18-097B	1800A -1	1 - H 5

PART NUMBER INDEX

PART NUMBER	SECTION	LOCATION	PART NUMBER	SECTION	LOCATION	PART NUMBER	SECTION	LOCATION	PART NUMBER	SECTION	LOCATION	PART NUMBER	SECTION	LOCATION
0000-18-097B	1800A -1	1 - H 5	1908-19-027	1910A -1	1 - N 5	3959-19-460A	1930A -1	1 - E 6	1758-19-616	1940A -1	1 - G 6	FT01-19-824	1920A -1	1 - C 6
0000-18-097B	1800A -1	1 - H 5	0454-19-028A	1910A -1	1 - N 5	3959-19-470A	1930A -1	1 - E 6	1758-19-617	1940A -1	1 - G 6	0338-19-825	1920A -2	1 - D 6
1480-18-100	1800A -1	1 - H 5	1758-19-028	1910A -1	1 - N 5	0338-19-475	1930A -1	1 - E 6	1758-19-618	1940A -1	1 - G 6	0338-19-826	1920A -2	1 - D 6
8245-18-100	1800A -1	1 - H 5	AT09-19-028B	1910A -1	1 - N 5	0338-19-476	1930A -1	1 - E 6	0338-19-619	1940A -1	1 - G 6	0338-19-827	1920A -2	1 - D 6
8871-18-106C	1800A -1	1 - H 5	8872-19-031	1950A -1	1 - H 6	0338-19-480	1930A -1	1 - E 6	0338-19-621	1930A -1	1 - E 6	0338-19-828	1920A -1	1 - C 6
8245-18-107	1800A -1	1 - H 5	1758-19-036A	1950A -1	1 - H 6	0338-19-486	1930A -1	1 - E 6	0338-19-622	1930A -1	1 - E 6	0338-19-829	1920A -2	1 - D 6
8248-18-110	1800A -1	1 - H 5	1758-19-055	1950A -1	1 - H 6	0338-19-487	1930A -1	1 - E 6	0338-19-623A	1930A -1	1 - E 6	0338-19-831	1920A -2	1 - D 6
8AF2-18-110A-BP	1800A -1	1 - H 5	3649-19-064A	1910A -1	1 - N 5	0338-19-488	1930A -1	1 - E 6	0338-19-624	1930A -1	1 - E 6	0338-19-832	1920A -2	1 - D 6
3648-18-111A	1800A -1	1 - H 5	8872-19-090B	1910A -1	1 - N 5	0338-19-498	1930A -1	1 - E 6	0338-19-631	1930A -1	1 - E 6	0338-19-833	1920A -2	1 - D 6
8871-18-111B	1800A -1	1 - H 5	AT09-19-090	1910A -1	1 - N 5	BU17-19-498	1930A -1	1 - E 6	0338-19-632	1930A -2	1 - F 6	1758-19-835	1920A -2	1 - D 6
0820-18-114	1800A -1	1 - H 5	1758-19-100	1910A -1	1 - N 5	0338-19-499	1930A -1	1 - E 6	0338-19-633	1930A -2	1 - F 6	1758-19-836	1920A -2	1 - D 6
8248-18-120	1800A -1	1 - H 5	1758-19-211C	1910A -1	1 - N 5	BU17-19-500A	1930A -1	1 - E 6	0338-19-634	1930A -2	1 - F 6	0338-19-837	1920A -2	1 - D 6
1480-18-130B	1800A -1	1 - H 5	0338-19-216	1910A -1	1 - N 5	3959-19-503	1930A -1	1 - E 6	0338-19-635	1930A -2	1 - F 6	1758-19-838	1950A -1	1 - H 6
1480-18-160A	1800A -1	1 - H 5	1758-19-220	1910A -1	1 - N 5	3959-19-504	1930A -1	1 - E 6	0338-19-636	1930A -2	1 - F 6	8872-19-838A	1950A -1	1 - H 6
1480-18-170B	1800A -1	1 - H 5	0338-19-223A	1910A -1	1 - N 5	3959-19-505	1930A -1	1 - E 6	0338-19-639	1930A -2	1 - F 6	8872-19-870A	1920A -2	1 - D 6
8871-18-180A	1800A -1	1 - H 5	1758-19-240	1910A -1	1 - N 5	3959-19-506	1930A -1	1 - E 6	0338-19-641	1930A -2	1 - F 6	8872-19-880	1920A -2	1 - D 6
8871-18-195A	1800A -1	1 - H 5	0338-19-245A	1910A -1	1 - N 5	3959-19-507	1930A -1	1 - E 6	0338-19-642	1930A -2	1 - F 6	0338-19-904A	1910A -1	1 - N 5
N201-18-200	1820A -1	1 - I 5	0338-19-247	1910A -1	1 - N 5	3959-19-508	1930A -1	1 - E 6	0338-19-643	1930A -2	1 - F 6	8872-19-911	1910A -1	1 - N 5
N249-18-200A	1820A -1	1 - I 5	0338-19-255	1910A -1	1 - N 5	0338-19-509	1930A -1	1 - E 6	0338-19-644	1930A -2	1 - F 6	0842-19-915A	1910A -1	1 - N 5
0107-18-216A	1820A -1	1 - I 5	BU01-19-256	1910A -1	1 - N 5	3959-19-509	1930A -1	1 - E 6	0338-19-645	1930A -2	1 - F 6	3876-19-916	1920A -2	1 - D 6
N221-18-300R	1830A -1	1 - J 5	BU01-19-257	1910A -1	1 - N 5	0338-19-510	1930A -1	1 - E 6	0338-19-646	1930A -2	1 - F 6	8872-19-920	1910A -1	1 - N 5
1757-18-311	1800A -1	1 - H 5	0338-19-258	1910A -1	1 - N 5	0338-19-511	1930A -1	1 - E 6	0338-19-647	1930A -2	1 - F 6	AT09-19-920A	1910A -1	1 - N 5
0114-18-327	1830A -1	1 - J 5	1758-19-310C	1920A -1	1 - C 6	0338-19-515	1930A -1	1 - E 6	0338-19-648	1930A -2	1 - F 6	8872-19-930A	1910A -1	1 - N 5
1881-18-361A	1800A -1	1 - H 5	AT09-19-310	1920A -1	1 - C 6	0338-19-530	1930A -1	1 - E 6	0842-19-650	1940A -1	1 - G 6	AT09-19-930A	1910A -1	1 - N 5
0222-18-375	1800A -1	1 - H 5	0338-19-331A	1920A -1	1 - C 6	0338-19-531	1930A -1	1 - E 6	0338-19-655	1940A -1	1 - G 6	1840-19-933	1910A -1	1 - N 5
0222-18-376	1800A -1	1 - H 5	0338-19-336	1920A -1	1 - C 6	0338-19-534	1930A -1	1 - E 6	0436-19-656	1930A -2	1 - F 6	AT11-19-934A	1910A -1	1 - N 5
0222-18-377	1800A -1	1 - H 5	0338-19-337	1920A -1	1 - C 6	0338-19-534	1940A -1	1 - G 6	0436-19-656	1940A -1	1 - G 6	AT09-19-961	1910A -1	1 - N 5
8311-18-381A	1800A -1	1 - H 5	0338-19-338	1920A -1	1 - C 6	0338-19-540	1930A -1	1 - E 6	0842-19-660	1940A -1	1 - G 6	2579-19-989	1910A -1	1 - N 5
N202-18-400R	1840A -1	1 - K 5	1758-19-341	1920A -1	1 - C 6	0338-19-550	1930A -1	1 - E 6	0338-19-663	1940A -1	1 - G 6	8021-20-548	4000A -1	1 - I 9
N221-18-400R	1840A -1	1 - K 5	0378-19-344	1920A -1	1 - C 6	0338-19-560	1930A -1	1 - E 6	0338-19-664	1940A -1	1 - G 6	N201-20-610A	1320A -1	1 - K 3
N202-18-401	1800A -1	1 - H 5	0338-19-360B	1930A -1	1 - E 6	0338-19-565	1930A -1	1 - E 6	0842-19-665	1940A -1	1 - G 6	N201-20-611	1320A -1	1 - K 3
8569-18-510A	6600A -1	2 - N 8	0338-19-361B	1920A -1	1 - C 6	0338-19-566	1930A -1	1 - E 6	0338-19-666	1940A -1	1 - G 6	N201-20-613	1320A -1	1 - K 3
N201-18-600	1800A -1	1 - H 5	0338-19-363	1920A -1	1 - C 6	0338-19-567	1930A -1	1 - E 6	0338-19-667	1940A -1	1 - G 6	N201-20-730	4000A -1	1 - I 9
N201-18-600	1800A -1	1 - H 5	0842-19-381	1920A -1	1 - C 6	0338-19-570	1930A -1	1 - E 6	0338-19-670A	1940A -1	1 - G 6	N201-20-770A	1380A -1	1 - F 4
2691-18-660	6620A -1	2 - F 9	0338-19-384	1920A -1	1 - C 6	0338-19-580	1940A -1	1 - G 6	0338-19-676	1940A -1	1 - G 6	N201-20-770A	1380AA-1	1 - H 4
8173-18-762	5540A -1	2 - N 4	0842-19-385	1920A -1	1 - C 6	0338-19-581	1940A -1	1 - G 6	0338-19-679	1910A -1	1 - N 5	N249-20-770	1380A -1	1 - F 4
8871-18-810A	1800A -1	1 - H 5	1758-19-386	1920A -1	1 - C 6	0338-19-590	1940A -1	1 - G 6	0338-19-701A	1950A -1	1 - H 6	N201-20-771	1380A -1	1 - F 4
8871-18-820C	6600A -1	2 - N 8	0338-19-388A	1920A -1	1 - C 6	0338-19-591	1940A -1	1 - G 6	0338-19-702A	1950A -1	1 - H 6	N201-20-771	1380AA-1	1 - H 4
8341-18-861A	1800A -1	1 - H 5	0338-19-389	1920A -1	1 - C 6	0338-19-593	1940A -1	1 - G 6	0338-19-703	1950A -1	1 - H 6	1480-20-950A	1380A -1	1 - F 4
8156-18-863B	1500A -2	1 - L 4	1758-19-391A	1920A -1	1 - C 6	0338-19-594	1940A -1	1 - G 6	0338-19-704	1950A -1	1 - H 6	1480-20-950A	1380AA-1	1 - H 4
8156-18-863B	1500AA-1	1 - M 4	1758-19-392A	1920A -1	1 - C 6	0338-19-595	1940A -1	1 - G 6	0338-19-706	1950A -1	1 - H 6	BU01-21-253	1910A -1	1 - N 5
8341-18-880	6600A -1	2 - N 8	0842-19-394	1920A -1	1 - C 6	0338-19-596	1940A -1	1 - G 6	1840-19-710	1920A -1	1 - C 6	0397-22-200	1930A -2	1 - F 6
N201-18-890	6600A -1	2 - N 8	1758-19-394A	1920A -1	1 - C 6	0338-19-598	1930A -1	1 - E 6	0338-19-731	1950A -1	1 - H 6	0398-22-333	1700A -1	1 - D 5
N233-18-890	6600A -1	2 - N 8	0338-19-395	1920A -1	1 - C 6	BT08-19-600	1940A -1	1 - G 6	0338-19-732	1950A -1	1 - H 6	1757-23-040B	1000A -1	1 - C 3
1480-18-910B	6600A -1	2 - N 8	1758-19-397	1920A -1	1 - C 6	0338-19-603	1940A -1	1 - G 6	0338-19-733C	1950A -1	1 - H 6	1480-23-103	1110A -1	1 - H 3
1480-18-912B	6600A -1	2 - N 8	0338-19-398	1920A -1	1 - C 6	0338-19-604	1940A -1	1 - G 6	0338-19-734A	1950A -1	1 - H 6	N225-23-103	1110A -1	1 - H 3
N201-18-940	6600A -1	2 - N 8	0338-19-398	1940A -1	1 - G 6	0338-19-605	1940A -1	1 - G 6	0338-19-735	1920A -1	1 - C 6	1480-23-113	1110A -1	1 - H 3
N202-18-940	6600A -1	2 - N 8	1758-19-431A	1950A -1	1 - H 6	0338-19-606	1940A -1	1 - G 6	0338-19-737	1920A -1	1 - C 6	N225-23-113	1110A -1	1 - H 3
N203-18-940	6600A -1	2 - N 8	1758-19-434	1950A -1	1 - H 6	0338-19-607	1940A -1	1 - G 6	0338-19-739	1920A -1	1 - C 6	1011-23-151A	1110A -1	1 - H 3
N231-18-940	6600A -1	2 - N 8	1758-19-440A	1950A -1	1 - H 6	0338-19-608	1940A -1	1 - G 6	8872-19-750C	1920A -1	1 - C 6	8871-23-180	1110A -1	1 - H 3
N232-18-940	6600A -1	2 - N 8	1758-19-443	1950A -1	1 - H 6	0338-19-609	1940A -1	1 - G 6	0338-19-768	1920A -1	1 - C 6	N201-23-200	1000A -1	1 - C 3
8182-18-970A	6600A -1	2 - N 8	8872-19-444B	6600A -1	2 - N 8	0338-19-610A	1940A -1	1 - G 6	1758-19-815	1920A -1	1 - C 6	N202-23-200	1000A -1	1 - C 3
1820-18-994	1800A -1	1 - H 5	0338-19-449	1950A -1	1 - H 6	1758-19-613	1940A -1	1 - G 6	1675-19-821	6600A -1	2 - N 8	N231-23-200	1000A -1	1 - C 3
1758-19-020B	1910A -1	1 - N 5	1758-19-450	1950A -1	1 - H 6	1758-19-614	1940A -1	1 - G 6	0338-19-822	1920A -1	1 - C 6	N232-23-200	1000A -1	1 - C 3
0842-19-025	1910A -1	1 - N 5	1758-19-455A	1950A -1	1 - H 6	1758-19-615	1940A -1	1 - G 6	BT07-19-823	1920A -1	1 - C 6	N201-23-310	1360A -1	1 - C 4

PART NUMBER INDEX

PART NUMBER	SECTION	LOCATION	PART NUMBER	SECTION	LOCATION	PART NUMBER	SECTION	LOCATION	PART NUMBER	SECTION	LOCATION	PART NUMBER	SECTION	LOCATION
N232-23-310	1360A -1	1 - C 4	N201-23-500A	1360A -2	1 - D 4	1757-24-526	1830A -1	1 - J 5	1758-24-750	1840A -2	1 - L 5	FA01-26-610A	2610A -1	1 - F 8
0730-23-318	1360A -1	1 - C 4	N201-23-501	1360A -2	1 - D 4	1011-24-530	1830A -1	1 - J 5	E301-24-750	1840A -2	1 - L 5	1175-26-615	2610A -1	1 - F 8
N201-23-327	1360A -1	1 - C 4	N201-23-502A	1360A -2	1 - D 4	N221-24-530	1830A -1	1 - J 5	N202-24-750	1840A -2	1 - L 5	FA01-26-630	2610A -1	1 - F 8
N201-23-328	1360A -1	1 - C 4	N201-23-503	1360A -2	1 - D 4	8028-24-533	1830A -1	1 - J 5	0222-24-752A	1840A -2	1 - L 5	FA01-26-640	2610A -1	1 - F 8
N201-23-329	1360A -1	1 - C 4	1570-23-507	1360A -2	1 - D 4	8028-24-535	1830A -1	1 - J 5	0222-24-753	1840A -2	1 - L 5	FA18-26-660	2610AA-1	1 - G 8
N201-23-330	1360A -1	1 - C 4	2183-23-508	1360A -2	1 - D 4	8086-24-540A	1830A -1	1 - J 5	E301-24-753	1840A -2	1 - L 5	FA01-26-710A	2610A -1	1 - F 8
N202-23-330	1360A -1	1 - C 4	N201-23-509	1360A -2	1 - D 4	N221-24-540	1830A -1	1 - J 5	0426-24-754	1840A -2	1 - L 5	FA01-26-800	2610A -1	1 - F 8
N203-23-330	1360A -1	1 - C 4	N201-23-510	1359A -1	1 - N 3	8173-24-550	1830A -1	1 - J 5	N226-24-754	1840A -2	1 - L 5	FA01-26-808	2610A -1	1 - F 8
N231-23-330	1360A -1	1 - C 4	1663-23-530	1360A -1	1 - C 4	N221-24-550	1830A -1	1 - J 5	1757-24-760	1840A -2	1 - L 5	FA01-26-810	2610A -1	1 - F 8
N232-23-330	1360A -1	1 - C 4	8871-23-530	1360A -1	1 - C 4	8173-24-560	1830A -1	1 - J 5	N226-24-760	1840A -2	1 - L 5	FA01-26-818	2610A -1	1 - F 8
8826-23-338	1360A -1	1 - C 4	0603-23-542	1360A -2	1 - D 4	N221-24-560	1830A -1	1 - J 5	E301-24-910	1820A -1	1 - L 5	FA01-26-832	2610A -1	1 - F 8
3743-23-340	1360A -1	1 - C 4	N201-23-652	1359A -1	1 - N 3	8086-24-581	1830A -1	1 - J 5	0259-25-021B	2500A -1	1 - C 8	GA02-26-832	2610A -1	1 - F 8
8341-23-349	1360A -1	1 - C 4	8341-23-672	1330A -1	1 - L 3	4130-24-590	1830A -1	1 - J 5	8BB1-25-060	2500A -1	1 - C 8	0613-26-922	2610A -1	1 - F 8
N201-23-350	1360A -1	1 - C 4	8245-23-673	1330A -1	1 - L 3	GE01-24-590	1830A -1	1 - J 5	0259-25-071B	2500A -1	1 - C 8	FA18-26-980A	2610AA-1	1 - G 8
N249-23-350	1359A -1	1 - N 3	1757-23-680	1330A -1	1 - L 3	N221-24-701	1840A -1	1 - K 5	0259-25-072B	2500A -1	1 - C 8	FA18-26-990A	2610AA-1	1 - G 8
8021-23-351	1360A -2	1 - D 4	3648-23-693A	1330A -1	1 - L 3	3648-24-705	1840A -1	1 - K 5	0259-25-073B	2500A -1	1 - C 8	0223-27-01C	2700A -1	1 - H 8
8980-23-354	1360A -1	1 - C 4	1757-23-713A	1371A -1	1 - E 4	N202-24-705	1840A -1	1 - K 5	0259-25-074B	2500A -1	1 - C 8	0223-27-018	2700A -1	1 - H 8
0222-23-355B	1360A -1	1 - C 4	0730-23-837	1400A -1	1 - I 4	N221-24-705	1840A -1	1 - K 5	0259-25-075B	2500A -1	1 - C 8	0223-27-020C	2700A -1	1 - H 8
0305-23-356	1360A -1	1 - C 4	0730-23-837	1400AA-1	1 - J 4	3648-24-709	1840A -1	1 - K 5	0259-25-076B	2500A -1	1 - C 8	0223-27-030	2700A -1	1 - H 8
8980-23-357	1360A -1	1 - C 4	1757-23-844	1400A -1	1 - I 4	N202-24-709	1840A -1	1 - K 5	0259-25-077A	2500A -1	1 - C 8	8051-27-100C	2700A -1	1 - H 8
N201-23-360	1360A -1	1 - C 4	1757-23-844	1400AA-1	1 - J 4	N221-24-709	1840A -1	1 - K 5	0259-25-077B	2500A -1	1 - C 8	M019-27-100A	2700A -1	1 - H 8
N201-23-361	1360A -1	1 - C 4	0820-23-845A	1400A -1	1 - I 4	1757-24-710C	1840A -1	1 - K 5	0259-25-078B	2500A -1	1 - C 8	M030-27-100	2700A -1	1 - H 8
N201-23-370	1360A -1	1 - C 4	0820-23-845A	1400AA-1	1 - J 4	N202-24-710A	1840A -1	1 - K 5	0259-25-079B	2500A -1	1 - C 8	M092-27-100B	2700A -1	1 - H 8
N202-23-370	1360A -1	1 - C 4	0820-23-847A	1400A -1	1 - I 4	N221-24-710	1840A -1	1 - K 5	8871-25-100	2500A -1	1 - C 8	8051-27-110D	2700A -1	1 - H 8
N231-23-370	1360A -1	1 - C 4	0820-23-847A	1400AA-1	1 - J 4	0426-24-712A	1840A -1	1 - K 5	M026-25-100	2500AA-1	1 - D 8	M005-27-120D	2700A -1	1 - H 8
N232-23-370	1360A -1	1 - C 4	1757-23-920G	1500A -1	1 - K 4	N202-24-712	1840A -1	1 - K 5	1393-25-123	2500A -1	1 - C 8	0820-27-150C	2700A -1	1 - H 8
N201-23-371	1360A -1	1 - C 4	1757-23-927	1500A -1	1 - K 4	0426-24-715A	1840A -1	1 - K 5	1456-25-123	2500AA-1	1 - D 8	M005-27-165	2700A -1	1 - H 8
N201-23-380	1360A -1	1 - C 4	1757-24-302	1820A -1	1 - I 5	N221-24-715	1840A -1	1 - K 5	1456-25-125	2500AA-1	1 - D 8	0305-27-171	2700A -1	1 - H 8
N201-23-390	1360A -1	1 - C 4	8245-24-303A	1820A -1	1 - I 5	N202-24-716	1840A -2	1 - L 5	0425-25-130B	2500A -1	1 - C 8	0221-27-210	2700A -1	1 - H 8
0823-23-394	1360A -2	1 - D 4	8245-24-304	1820A -1	1 - I 5	N202-24-720	1840A -2	1 - L 5	8871-26-020D	2600A -1	1 - E 8	0755-27-210	2700A -1	1 - H 8
8871-23-401	1360A -1	1 - C 4	8245-24-305	1820A -1	1 - I 5	N202-24-721	1840A -1	1 - K 5	FA19-26-020B	2600A -1	1 - E 8	M020-27-230	2700A -1	1 - H 8
0823-23-402A	1360A -2	1 - D 4	1480-24-308	1820A -1	1 - I 5	N202-24-722	1840A -1	1 - K 5	0259-26-041A	2600A -1	1 - E 8	0290-27-231B	2700A -1	1 - H 8
8871-23-409A	1360A -2	1 - D 4	8245-24-310B	1820A -1	1 - I 5	0426-24-725	1840A -1	1 - K 5	0259-26-051	2600A -1	1 - E 8	0290-27-231C	2700A -1	1 - H 8
8871-23-411	1360A -1	1 - C 4	8AF1-24-310A-BP	1820A -1	1 - I 5	8872-24-725	1840A -1	1 - K 5	0886-26-060	2600A -1	1 - E 8	8051-27-235	2700A -1	1 - H 8
1480-23-421	1360A -2	1 - D 4	8248-24-314	1820A -1	1 - I 5	0426-24-726	1840A -1	1 - K 5	FA01-26-111	2600A -1	1 - E 8	8051-27-236	2700A -1	1 - H 8
N231-23-420	1360A -2	1 - D 4	N236-24-314	1820A -1	1 - I 5	N202-24-728	1840A -1	1 - K 5	FA18-26-130	2610AA-1	1 - G 8	0820-27-251A	2700A -1	1 - H 8
1955-23-421	1360A -1	1 - C 4	8248-24-316	1820A -1	1 - I 5	N202-24-729	1840A -1	1 - K 5	3728-26-132	2610A -1	1 - F 8	M020-27-251	2700A -1	1 - H 8
N202-23-421	1360A -1	1 - C 4	N201-24-330	1820A -1	1 - I 5	N202-24-729A	1840A -1	1 - K 5	3728-26-132	2610AA-1	1 - G 8	0290-27-252	2700A -1	1 - H 8
N201-23-423	1360A -2	1 - D 4	1757-24-334	1820A -1	1 - I 5	0222-24-730	1840A -1	1 - K 5	FA18-26-140	2610AA-1	1 - G 8	M020-27-252	2700A -1	1 - H 8
N202-23-423	1360A -2	1 - D 4	3648-24-340	1820A -1	1 - I 5	E301-24-730	1840A -1	1 - K 5	8871-26-151A	2600A -1	1 - E 8	0290-27-253	2700A -1	1 - H 8
8871-23-424	1360A -2	1 - D 4	1480-24-350	1820A -1	1 - I 5	N202-24-730	1840A -1	1 - K 5	8531-26-152	2600A -1	1 - E 8	M020-27-253	2700A -1	1 - H 8
3743-23-425	1360A -2	1 - D 4	1480-24-350A	1820A -1	1 - I 5	N221-24-730	1840A -2	1 - L 5	0187-26-154	2600A -1	1 - E 8	0290-27-254	2700A -1	1 - H 8
N201-23-426	1360A -1	1 - C 4	N201-24-351	1820A -1	1 - I 5	N221-24-730	1840A -1	1 - K 5	0259-26-155	2600A -1	1 - E 8	0221-27-255C	2700A -2	1 - I 8
N201-23-430	1360A -2	1 - D 4	N231-24-351	1820A -1	1 - I 5	0426-24-731	1840A -2	1 - L 5	FA01-26-251	2610A -1	1 - F 8	M020-27-255	2700A -2	1 - I 8
N202-23-430	1360A -2	1 - D 4	8248-24-360	1820A -1	1 - I 5	1030-24-731A	1840A -2	1 - L 5	FA18-26-251	2610AA-1	1 - G 8	0290-27-256	2700A -1	1 - H 8
N231-23-430	1360A -2	1 - D 4	8245-24-368A	1820A -1	1 - I 5	N202-24-731	1840A -2	1 - L 5	FA01-26-280	2610A -1	1 - F 8	M020-27-256	2700A -1	1 - H 8
N232-23-430	1360A -2	1 - D 4	8173-24-501A	1830A -1	1 - J 5	8872-24-736	1840A -2	1 - L 5	0710-26-288	2610A -1	1 - F 8	M020-27-257	2700A -1	1 - H 8
8649-23-434	1360A -2	1 - D 4	N221-24-501	1830A -1	1 - J 5	0222-24-740	1840A -2	1 - L 5	3648-26-288	2610A -1	1 - F 8	M020-27-258	2700A -2	1 - I 8
N201-23-440	1360A -2	1 - D 4	0820-24-503	1830A -1	1 - J 5	N202-24-740	1840A -2	1 - L 5	FA01-26-290	2610A -1	1 - F 8	0290-27-259	2700A -1	1 - H 8
2090-23-452	1360A -2	1 - D 4	8173-24-510A	1830A -1	1 - J 5	0222-24-741	1840A -2	1 - L 5	GA02-26-315	2610A -1	1 - F 8	M020-27-259	2700A -2	1 - I 8
N201-23-460	1360A -1	1 - C 4	N221-24-510	1330A -1	1 - J 5	N202-24-741	1840A -2	1 - L 5	FA01-26-341	2610A -1	1 - F 8	0305-27-261	2700A -2	1 - I 8
N201-23-480	1360A -2	1 - D 4	8173-24-520	1830A -1	1 - J 5	N202-24-743	1840A -2	1 - L 5	1011-26-342	2610A -1	1 - F 8	M020-27-261	2700A -2	1 - I 8
3743-23-488	1360A -1	1 - C 4	N221-24-520	1830A -1	1 - J 5	N202-24-744	1840A -2	1 - L 5	FA01-26-345	2610A -1	1 - F 8	0114-27-262	2700A -2	1 - I 8
N201-23-490	1360A -2	1 - D 4	8173-24-521	1830A -1	1 - J 5	N202-24-745	1840A -2	1 - L 5	FA01-26-38Z	2610A -1	1 - F 8	M020-27-265	2700A -2	1 - I 8
N201-23-492	1360A -2	1 - D 4	8173-24-522	1830A -1	1 - J 5	N202-24-746	1840A -2	1 - L 5	FA01-26-391	2610A -1	1 - F 8	0290-27-301	2700A -2	1 - I 8

PART NUMBER INDEX

PART NUMBER	SECTION	LOCATION	PART NUMBER	SECTION	LOCATION	PART NUMBER	SECTION	LOCATION	PART NUMBER	SECTION	LOCATION	PART NUMBER	SECTION	LOCATION
0290-27-302	2700A -2	1 - I 8	FA01-32-110	3210A -1	1 - M 8	8545-33-047	3300A -1	1 - C 9	8871-34-850D	3410A -1	1 - E 9	1480-40-318A	4000A -1	1 - I 9
0221-27-350	2700A -2	1 - I 8	FA24-32-110B	3210A -1	1 - M 8	0259-33-049	3300A -1	C 9	8871-34-860D	3410A -1	1 - E 9	1480-40-325	4000A -1	1 - I 9
0223-27-401A	2700A -2	1 - I 8	FA01-32-120	3210A -1	1 - M 8	1312-33-065	3300A -1	1 - C 9	FA01-34-910B	3400A -1	1 - D 9	N326-40-353	4000A -1	1 - I 9
0223-27-402A	2700A -2	1 - I 8	FA24-32-120	3210A -1	1 - M 8	0419-33-071	3300A -1	1 - C 9	8171-34-970	3400A -1	1 - D 9	8118-40-355	4000A -1	1 - I 9
0223-27-403A	2700A -2	1 - I 8	FA01-32-130	3210A -1	1 - M 8	8002-33-075	3300A -1	1 - C 9	9996-36-310	1710A -1	1 - E 5	8134-40-355	1310A -1	1 - J 3
0223-27-404A	2700A -2	1 - I 8	FA24-32-130	3210A -1	1 - M 8	9996-33-130	1720A -1	1 - G 5	9996-36-315	1710A -1	1 - E 5	8134-40-355	4000A -1	1 - I 9
0223-27-405A	2700A -2	1 - I 8	8180-32-140	3210A -1	1 - M 8	1029-33-165	3700A -1	1 - F 9	9996-36-330	1710A -1	1 - E 5	1480-40-356	4000A -1	1 - I 9
0223-27-406A	2700A -2	1 - I 8	FA01-32-141	3210A -1	1 - M 8	8531-33-165	3700A -1	1 - F 9	9996-36-330	1710A -1	1 - E 5	8182-40-356	4000A -1	1 - I 9
0223-27-407A	2700A -2	1 - I 8	FA24-32-141A	3210A -1	1 - M 8	FA46-33-165P-01	3700A -1	1 - F 9	8871-37-190	3700A -1	1 - F 9	1480-40-375	4000A -1	1 - I 9
0223-27-408A	2700A -2	1 - I 8	FA01-32-150	3210A -1	1 - M 8	8371-33-251A	3300A -1	1 - C 9	G002-37-190	3700A -1	1 - F 9	N201-40-400	4000A -1	1 - I 9
0223-27-409A	2700A -2	1 - I 8	FA24-32-150	3210A -1	1 - M 8	8871-33-260A	3300A -1	1 - C 9	GB23-37-190	3700A -1	1 - F 9	N231-40-400	4000A -1	1 - I 9
0223-27-411A	2700A -2	1 - I 8	FA01-32-170	3210A -1	1 - M 8	8871-33-270A	3300A -1	1 - C 9	FA01-37-191	3700A -1	1 - F 9	8871-40-401	4000A -1	1 - I 9
0223-27-412A	2700A -2	1 - I 8	FA24-32-170	3210A -1	1 - M 8	8341-33-651	3300A -1	1 - C 9	8871-37-192	3700A -1	1 - F 9	8871-40-405A	4000A -1	1 - I 9
0223-27-413A	2700A -2	1 - I 8	8871-32-180	3210A -1	1 - M 8	8341-33-651A	3300A -1	1 - C 9	8531-37-193C	3700A -1	1 - F 9	1480-40-500	4000A -1	1 - I 9
0223-27-414A	2700A -2	1 - I 8	8871-32-182	3210A -1	1 - M 8	0233-33-691	2610AA-1	1 - G 8	8871-37-790D	3700A -2	1 - G 9	N231-40-500	4000A -1	1 - I 9
0223-27-415A	2700A -2	1 - I 8	0603-32-186	5010A -1	2 - F 3	0233-33-691	3300A -1	1 - C 9	9965-38-503	3700A -1	1 - F 9	8871-40-551	4000A -1	1 - I 9
8871-28-011B	2800A -1	1 - J 8	0208-32-188	3210A -1	1 - M 8	0259-33-691	2610A -1	1 - F 8	9965-38-503 K3	3700A -1	1 - F 9	8871-40-560	4000A -1	1 - I 9
8871-28-013B	2800A -1	1 - J 8	1757-32-220	3210A -1	1 - M 8	0259-33-691	4140A -1	1 - K 9	8871-39-021B	3900A -1	1 - H 9	1480-40-640A	4000A -2	1 - J 9
8871-28-013C	2800A -1	1 - J 8	8871-32-261	3230A -1	1 - N 8	0259-33-693	2610A -1	1 - F 8	1668-39-040D	3900A -1	1 - H 9	1480-40-652	4000A -2	1 - J 9
0305-28-111B	2800A -1	1 - J 8	8545-32-278	3210A -1	1 - M 8	0259-33-693	2610AA-1	1 - G 8	8545-39-040	3900A -1	1 - H 9	1480-40-728	4000A -2	1 - J 9
1243-28-111	2800A -1	1 - J 8	8021-32-279	3230A -1	1 - N 8	0259-33-693	3300A -1	1 - C 9	1668-39-045B	3900A -1	1 - H 9	N201-40-740A	4000A -2	1 - J 9
8001-28-114	3410A -1	1 - E 9	8531-32-279	3230A -1	1 - N 8	0259-33-693	4140A -1	1 - K 9	8788-39-055	3900A -1	1 - H 9	1480-40-750	4000A -2	1 - J 9
8871-28-120B	2810A -1	1 - K 8	8871-32-301C	3400A -1	1 - D 9	8341-33-699	3300A -1	1 - C 9	1011-39-340A	3900A -1	1 - H 9	N231-40-810	4000A -2	1 - J 9
FA01-28-120A	2810A -1	1 - K 8	8871-32-311C	3400A -1	1 - D 9	FA57-33-980	3300A -1	1 - C 9	1391-39-349	3410A -1	1 - E 9	N201-40-811	4000A -2	1 - J 9
FA01-28-120B	2810A -1	1 - K 8	0603-32-315	3400A -1	1 - D 9	FA57-33-990	3300A -1	1 - C 9	F001-39-372	3900A -1	1 - H 9	1480-40-815	4000A -2	1 - J 9
8871-28-151A	2810A -1	1 - K 8	8871-32-320A	3230A -1	1 - N 8	F001-34-011A	3400A -1	1 - D 9	F001-39-375	3900A -1	1 - H 9	8545-40-815	4000A -2	1 - J 9
8980-28-151	2810A -1	1 - K 8	1524-32-329B	3230A -1	1 - N 8	FA01-34-011A	3400A -1	1 - D 9	1480-39-380A	3900A -1	1 - H 9	1480-40-820	4000A -2	1 - J 9
FA01-28-151	2810A -1	1 - K 8	0866-32-341	3230A -1	1 - N 8	FA01-34-012	3400A -1	1 - D 9	1481-39-380B	3900A -1	1 - H 9	N201-40-830	4000A -2	1 - J 9
8871-28-155	2810A -1	1 - K 8	8173-32-359	3210A -1	1 - M 8	1011-34-013	3400A -1	1 - D 9	1013-39-382A	3900A -1	1 - H 9	1480-40-841A	4000A -2	1 - J 9
FA01-28-155	2810A -1	1 - K 8	2113-32-365	3230A -1	1 - N 8	FA01-34-015	3400A -1	1 - D 9	0884-39-383A	3900A -1	1 - H 9	N229-40-841	4000A -2	1 - J 9
8871-28-156	2810A -1	1 - K 8	8871-32-411	3210A -1	1 - M 8	1011-34-019	3400A -1	1 - D 9	0884-39-384	3900A -1	1 - H 9	0727-41-022	4300A -1	1 - N 9
8980-28-156	2810A -1	1 - K 8	8871-32-412	3210A -1	1 - M 8	8871-34-111A	3400A -1	1 - D 9	8599-39-384A	3900A -1	1 - H 9	FA01-41-030	4300A -1	1 - N 9
FA01-28-156	2810A -1	1 - K 8	FA01-32-420	3210A -1	1 - M 8	8871-34-131A	3410A -1	1 - E 9	0884-39-385A	3900A -1	1 - H 9	0727-41-131	4300A -1	1 - N 9
8871-28-157	2810A -1	1 - K 8	FA24-32-420	3210A -1	1 - M 8	8871-34-133A	3410A -1	1 - E 9	0884-39-386	3900A -1	1 - H 9	9938-41-200F	1040A -1	1 - E 3
8871-28-160	2800A -1	1 - J 8	8871-32-429A	3210A -1	1 - M 8	8871-34-134A	3410A -1	1 - E 9	8871-40-010	4000A -1	1 - I 9	9938-41-200F	1500A -1	1 - K 4
8871-28-170	2800A -1	1 - J 8	8532-32-740	3200A -1	1 - L 8	8871-34-135A	3410A -1	1 - E 9	1114-40-061	4000A -1	1 - I 9	0613-41-308	4400A -1	1 - F 10
8871-28-180	2800A -1	1 - J 8	8871-32-740B	3200A -1	1 - L 8	8871-34-136B	3410A -1	1 - E 9	1480-40-070	4000A -1	1 - I 9	F005-41-341	4140A -1	1 - K 9
8871-28-200	2800A -1	1 - J 8	8532-32-750	3200A -1	1 - L 8	8871-34-137A	3410A -1	1 - E 9	N225-40-070B	4000A -1	1 - I 9	0088-41-352A	4300A -1	1 - N 9
8871-28-300A	2800A -1	1 - J 8	8871-32-750	3200A -1	1 - L 8	8871-34-151	3410A -1	1 - E 9	1480-40-073	4000A -1	1 - I 9	8871-41-370	4140A -1	1 - K 9
8871-28-320	2800A -1	1 - J 8	8531-32-800	3200A -1	1 - L 8	8871-34-152	3410A -1	1 - E 9	N225-40-074	4000A -1	1 - I 9	G011-41-380	4140A -1	1 - K 9
0710-28-775	2810A -1	1 - K 8	8531-32-800 01	3200A -1	1 - L 8	1243-34-153	3410A -1	1 - E 9	1480-40-076	4000A -1	1 - I 9	9956-41-400	1040A -1	1 - E 3
8871-28-775	2800A -1	1 - J 8	8871-32-800	3200A -1	1 - L 8	FA01-34-155	3410A -1	1 - E 9	N225-40-076B	4000A -1	1 - I 9	G011-41-400	4140A -1	1 - K 9
0223-28-776	2800A -1	1 - J 8	8871-32-800 01	3200A -1	1 - L 8	8871-34-156A	3410A -1	1 - E 9	1480-40-077	4000A -1	1 - I 9	FA01-41-610	4160A -1	1 - L 9
0223-28-776	3410A -1	1 - E 9	8531-32-811	3200A -1	1 - L 8	0603-34-157A	3410A -1	1 - E 9	1480-40-080B	4000A -1	1 - I 9	8239-41-619	4160A -1	1 - L 9
0710-28-776	2810A -1	1 - K 8	8871-32-862	3210A -1	1 - M 8	0603-34-158	3410A -1	1 - E 9	1480-40-085A	4000A -1	1 - I 9	0259-41-644	4160A -1	1 - L 9
0259-28-778	2800A -1	1 - J 8	8180-32-980B	3200A -1	1 - L 8	0866-34-158	2800A -1	1 - J 8	1114-40-108B	4000A -1	1 - I 9	3597-41-650A	4160A -1	1 - L 9
8532-32-018	3200A -1	1 - L 8	8180-32-980B00	3200A -1	1 - L 8	1243-34-159	3400A -1	1 - D 9	1114-40-160	4000A -1	1 - I 9	FA01-41-660	4160A -1	1 - L 9
UA47-32-018	3200A -1	1 - L 8	8344-32-980B	3200A -1	1 - L 8	8871-34-222	3410A -1	1 - E 9	0820-40-166	4000A -1	1 - I 9	FA42-41-660A	4160A -1	1 - L 9
8532-32-049	3200A -1	1 - L 8	8344-32-980B00	3200A -1	1 - L 8	FA01-34-340A	3400A -1	1 - D 9	8871-40-180	4000A -1	1 - I 9	0118-41-681	4160A -1	1 - L 9
8532-32-049 00	3200A -1	1 - L 8	8349-32-980	3200A -1	1 - L 8	FA01-34-384	3400A -1	1 - D 9	1480-40-200	4000A -1	1 - I 9	0118-41-682	4160A -1	1 - L 9
8871-32-049C	3200A -1	1 - L 8	8349-32-980 00	3200A -1	1 - L 8	FA01-34-390A	3400A -1	1 - D 9	N231-40-200	4000A -1	1 - I 9	8871-41-711B	4160A -1	1 - L 9
8871-32-049C00	3200A -1	1 - L 8	8532-32-984	3200A -1	1 - L 8	8173-34-460B	3400A -1	1 - D 9	1480-40-270	4000A -1	1 - I 9	FA01-41-920	4140A -1	1 - K 9
1244-32-071A	3210A -1	1 - M 8	8871-32-984	3200A -1	1 - L 8	8531-34-565	3400A -1	1 - D 9	1480-40-280A	4000A -1	1 - I 9	FA42-41-920A	4140A -1	1 - K 9
8182-32-071	3210A -1	1 - M 8	0259-33-042	3300A -1	1 - C 9	8171-34-731	3400A -1	1 - D 9	N231-40-300	4000A -1	1 - I 9	0866-42-046	4200A -1	1 - M 9
8182-32-071A	3210A -1	1 - M 8	8531-33-043	3300A -1	1 - C 9	8871-34-800C	3410A -1	1 - E 9	N201-40-310A	4000A -1	1 - I 9	FA01-42-110A	4200A -1	1 - M 9

PART NUMBER INDEX

PART NUMBER	SECTION	LOCATION	PART NUMBER	SECTION	LOCATION	PART NUMBER	SECTION	LOCATION	PART NUMBER	SECTION	LOCATION	PART NUMBER	SECTION	LOCATION
FA01-42-110B	4200A -1	1 - M 9	FA07-43-370	4360A -1	1 - D10	0866-44-187A	4400A -1	1 - F10	F025-46-021	4600A -1	1 - H10	FA01-50-012	5000A -1	2 - D 3
FA42-42-110	4200A -1	1 - M 9	FA07-43-370	4360AA-1	1 - E10	0866-44-189	4400A -1	1 - F10	8174-46-022	4600A -1	1 - H10	FA01-50-013	5010A -1	2 - F 3
9956-42-200	1500A -1	1 - K 4	FA07-43-400	4340A -1	1 - C10	0118-44-375	4400A -1	1 - F10	8872-46-030C	4600A -1	1 - H10	FA01-50-014	5000A -1	2 - D 3
8871-42-210C	4200A -1	1 - M 9	FA18-43-400	4340A -1	1 - C10	FA16-44-410B	4400A -1	1 - F10	8872-46-030C00	4600A -1	1 - H10	FA01-50-014	5010A -1	2 - F 3
8344-42-241	4200A -1	1 - M 9	H001-43-443	4340A -1	1 - C10	FA54-44-410A	4400A -1	1 - F10	HA19-46-030A	4600A -1	1 - H10	FA01-50-015	5000A -1	2 - D 3
8871-42-242A	4200A -1	1 - M 9	3597-43-540	4340A -1	1 - C10	FA16-44-420A	4400A -1	1 - F10	HA19-46-030A00	4600A -1	1 - H10	FA01-50-015	5010A -1	2 - F 3
8344-42-245	4200A -1	1 - M 9	8531-43-542	4340A -1	1 - C10	FA54-44-420A	4400A -1	1 - F10	8872-46-032	4600A -1	1 - H10	FA01-50-016	5000A -1	2 - D 3
8871-42-250B	4200A -1	1 - M 9	FA18-43-605A	4360AA-1	1 - E10	1011-44-439	4400A -1	1 - F10	1244-46-035	4600A -1	1 - H10	FA01-50-030A	5000A -1	2 - D 3
0223-42-307	1380A -1	1 - F 4	1114-43-608B	4360AA-1	1 - E10	8871-44-439	4400A -1	1 - F10	1244-46-038	4600A -1	1 - H10	FA01-50-036	5000A -1	2 - D 3
0223-42-307	1380AA-1	1 - H 4	8871-43-608	4360A -1	1 - D10	0305-44-471	4400A -1	1 - F10	1244-46-055	4600A -1	1 - H10	FA01-50-036	5010A -1	2 - F 3
0223-42-307	4200A -1	1 - M 9	1114-43-609A	4360AA-1	1 - E10	FA01-45-111B	4500A -1	1 - G10	8202-46-061A	4600A -1	1 - H10	FA01-50-037	5000A -1	2 - D 3
8871-42-365	4200A -1	1 - M 9	8595-43-609	4360A -1	1 - D10	FA42-45-111A	4500A -1	1 - G10	2375-46-062	4600A -1	1 - H10	FA01-50-040	5000A -1	2 - D 3
0866-42-366B	4200A -1	1 - M 9	8595-43-609	4360AA-1	1 - E10	FA01-45-112	4500A -1	1 - G10	1481-46-081A	4600A -1	1 - H10	FA01-50-042	5000A -1	2 - D 3
8871-42-410A	4200A -1	1 - M 9	0136-43-635	4140A -1	1 - K 9	8344-45-123	4500A -1	1 - G10	FA03-46-083	4600A -1	1 - H10	FA01-50-050	5000A -1	2 - D 3
FA54-42-410	4200A -1	1 - M 9	0136-43-635	4360A -1	1 - D10	8344-45-125	4500A -1	1 - G10	1481-46-084A	4600A -1	1 - H10	FA01-50-052	5000A -1	2 - D 3
FA01-42-431B	4200A -1	1 - M 9	0136-43-635	4360AA-1	1 - E10	FA42-45-125	4500A -1	1 - G10	1015-46-085	4300A -1	1 - N 9	FA01-50-070	5000A -1	2 - D 3
FA01-42-440A	0900A -1	2 - C 3	0305-43-635	4360AA-1	1 - E10	8344-45-126	4500A -1	1 - G10	1015-46-085	4600A -1	1 - H10	FA01-50-080	5000A -1	2 - D 3
H043-42-451A	4200A -1	1 - M 9	0305-43-635	4360AA-1	1 - E10	FA42-45-126A	4500A -1	1 - G10	FA03-46-110	4600A -1	1 - H10	FA01-50-150A	5000A -1	2 - D 3
H043-42-452B	4200A -1	1 - M 9	B001-43-635	4360A -1	1 - D10	8871-45-131A	4500A -1	1 - G10	1481-46-150A	4600A -1	1 - H10	FA01-50-180	5000A -1	2 - D 3
0259-42-459	5180A -1	2 - E 4	B001-43-635	4360A -1	1 - D10	8871-45-151A	4500A -1	1 - G10	1481-46-160	4600A -1	1 - H10	FA01-50-211	5010A -1	2 - F 3
UA64-42-459	4200A -1	1 - M 9	G001-43-640	4340A -1	1 - C10	8871-45-160	4500A -1	1 - G10	FA03-46-571	4600A -1	1 - H10	FA01-50-220	5010A -1	2 - F 3
F023-42-470B	4200A -1	1 - M 9	FA18-43-642A	4360AA-1	1 - E10	FA23-45-160A	4500A -1	1 - G10	0223-46-683	4300A -1	1 - N 9	FA01-50-223	5010A -1	2 - F 3
FA01-42-480	4200A -1	1 - M 9	FA07-43-650	4360A -1	1 - D10	919-45-170A	4500A -1	1 - G10	1015-46-684A	4600A -1	1 - H10	FA01-50-230	5010A -1	2 - F 3
FA01-42-490	4200A -1	1 - M 9	FA18-43-650	4360AA-1	1 - E10	FA23-45-181	4500A -1	1 - G10	1481-46-684	4600A -1	1 - H10	8871-50-231	5010A -1	2 - F 3
8562-42-530	4200A -1	1 - M 9	FA07-43-660	4360A -1	1 - D10	FA23-45-182	4500A -1	1 - G10	8872-46-685	4600A -1	1 - H10	8871-50-232	5010A -1	2 - F 3
8871-42-571B	4200A -1	1 - M 9	FA18-43-660	4360AA-1	1 - E10	FA23-45-190A	4500A -1	1 - G10	8341-49-240	3300A -1	1 - C 9	FA01-50-232	5010A -1	2 - F 3
F001-42-581A	4200A -1	1 - M 9	8573-43-694	4340A -1	1 - C10	FA01-45-280	4360A -1	1 - D10	FA18-49-240	2610AA-1	1 - G 8	FA01-50-240	5010A -1	2 - F 3
FA01-42-581	4200A -1	1 - M 9	FA07-43-750	4360A -1	1 - D10	FA01-45-280	4360AA-1	1 - E10	8341-49-250	3300A -1	1 - C 9	FA01-50-242	5010A -1	2 - F 3
8871-42-710B	4200A -1	1 - M 9	FA07-43-750	4360AA-1	1 - E10	FA42-45-280	4360A -1	1 - D10	FA18-49-250	2610AA-1	1 - G 8	G001-50-242	5180A -1	2 - E 4
3870-42-720A	4200A -1	1 - M 9	8871-43-785A	4360A -1	1 - D10	FA42-45-280	4360AA-1	1 - E10	8341-49-270	3300A -1	1 - C 9	FA01-50-280A	5010A -1	2 - F 3
8871-42-720A	4200A -1	1 - M 9	FA16-43-800	4340A -1	1 - C10	FA01-45-320	4360A -1	1 - D10	FA18-49-270	2610AA-1	1 - G 8	FA01-50-330A	5010A -1	2 - F 3
3870-42-725	4200A -1	1 - M 9	FA18-43-810	4360AA-1	1 - E10	FA01-45-320	4360AA-1	1 - E10	8871-49-280A	3300A -1	1 - C 9	FA01-50-380	5010A -1	2 - F 3
8871-42-745	4200A -1	1 - M 9	FA07-43-820	4360A -1	1 - D10	FA54-45-360	4360A -1	1 - D10	FA18-49-280A	2610AA-1	1 - G 8	8871-50-510C	5040A -1	2 - H 3
8531-42-761	4200A -1	1 - M 9	FA18-43-820A	4360AA-1	1 - E10	FA54-45-360	4360AA-1	1 - E10	8341-49-290A	3300A -1	1 - C 9	8871-50-516	5030A -1	2 - G 3
8341-42-910A	4200A -1	1 - M 9	1480-43-830A	4340A -1	1 - C10	FA01-45-510	4140A -1	1 - K 9	FA18-49-290	2610AA-1	1 - G 8	8871-50-517	5030A -1	2 - G 3
8871-42-920	4200A -1	1 - M 9	8871-43-836	4340A -1	1 - C10	FA01-45-611A	4500A -1	1 - G10	8871-49-310	3400A -1	1 - D 9	8871-50-520C	5040A -1	2 - H 3
0225-43-028A	4300A -1	1 - N 9	FA01-43-840	4340A -1	1 - C10	FA42-45-611B	4500A -1	1 - G10	8871-49-320	3400A -1	1 - D 9	8871-50-526	5030A -1	2 - G 3
8871-43-028A	4300A -1	1 - N 9	FA07-43-900	4360A -1	1 - D10	FA01-45-711	4500A -1	1 - G10	H005-49-460	4140A -1	1 - K 9	8871-50-527	5050A -1	2 - G 3
B001-43-029	4300A -1	1 - N 9	FA07-43-900	4360AA-1	1 - E10	FA42-45-711C	4500A -1	1 - G10	G011-49-470	4140A -1	1 - K 9	8871-50-608	5030A -1	2 - G 3
FA01-43-030	4300A -1	1 - N 9	FA48-43-900	4360AA-1	1 - E10	FA01-45-712	4500A -1	1 - G10	GA02-49-520A	4140A -1	1 - K 9	1243-50-609	5030A -1	2 - G 3
FA03-43-030	4300A -1	1 - N 9	GA02-43-980	4360A -1	1 - D10	FA30-45-712	4500A -1	1 - G10	GA02-49-530	4140A -1	1 - K 9	FA01-50-681	5060A -1	2 - I 3
FA05-43-030	4300A -1	1 - N 9	GA02-43-980	4360AA-1	1 - E10	FA42-45-712B	4500A -1	1 - G10	GA02-45-570	4140A -1	1 - K 9	FA02-50-682	5060A -1	2 - I 3
FA01-43-041	4300A -1	1 - N 9	FA01-44-010B	4400A -1	1 - F10	FA01-45-713	4500A -1	1 - G10	GA02-49-570B	4140A -1	1 - K 9	FA02-50-683	5060A -1	2 - I 3
FA01-43-042	4300A -1	1 - N 9	FA01-44-010B00	4400A -1	1 - F10	8871-45-715	4500A -1	1 - G10	B093-49-580	4340A -1	1 - C10	FA02-50-684	5060A -1	2 - I 3
0866-43-062	4300A -1	1 - N 9	FA54-44-031	4400A -1	1 - F10	8173-45-901A	4500A -1	1 - G10	GA02-49-580B	4140A -1	1 - K 9	FA01-50-685	5060A -1	2 - I 3
FA16-43-063	4300A -1	1 - N 9	FA01-44-032	4400A -1	1 - F10	8171-45-903A	4500A -1	1 - G10	FA18-49-610	4340A -1	1 - C10	FA01-50-691	5060A -1	2 - I 3
FA01-43-070C	4300A -1	1 - N 9	0221-44-033	4400A -1	1 - F10	8173-45-903	4910A -1	1 - N 5	G001-49-610	4340A -1	1 - C10	FA02-50-692	5060A -1	2 - I 3
1011-43-082A	4300A -1	1 - N 9	0221-44-033 GO	4400A -1	1 - F10	8173-45-903	4360A -1	1 - D10	FA18-49-640	4340A -1	1 - C10	FA02-50-693	5060A -1	2 - I 3
8872-43-090	4300A -1	1 - N 9	FA01-44-034A	4400A -1	1 - F10	8173-45-903	4360AA-1	1 - E10	G001-49-640	4340A -1	1 - C10	FA02-50-694	5060A -1	2 - I 3
0259-43-140	4300A -1	1 - N 9	FA01-44-024A00	4400A -1	1 - F10	8173-45-903	4500A -1	1 - G10	G001-49-652	4340A -1	1 - C10	FA01-50-695	5060A -1	2 - I 3
1872-43-140	4300A -1	1 - N 9	1243-44-044A	4400A -1	1 - F10	FA42-45-903	4500A -1	1 - G10	FA07-49-680	4340A -1	1 - C10	FA01-50-711A	5005A -1	2 - E 3
1872-43-140	4300A -1	1 - N 9	FA01-44-051	4400A -1	1 - F10	FA42-45-904	4500A -1	1 - G10	0305-49-686B	4140A -1	1 - K 9	8871-50-720	5005A -1	2 - E 3
FA02-43-303	4300A -1	1 - N 9	B001-44-053	4400A -1	1 - F10	1481-46-010	4600A -1	1 - H10	0305-49-686B	4340A -1	1 - C10	8871-50-741	5005A -1	2 - E 3
FA07-43-360	4360A -1	1 - D10	B001-44-054	4400A -1	1 - F10	1481-46-019	4600A -1	1 - H10	F001-49-720	4340A -1	1 - C10	8871-50-761	5005A -1	2 - E 3
FA07-43-360	4360AA-1	1 - E10	1480-44-150A	4400A -1	1 - F10	8872-46-021A	4600A -1	1 - H10	FA01-49-790	3400A -1	1 - D 9	8871-50-791A	5180A -1	2 - E 4

PART NUMBER INDEX

PART NUMBER	SECTION	LOCATION	PART NUMBER	SECTION	LOCATION	PART NUMBER	SECTION	LOCATION	PART NUMBER	SECTION	LOCATION	PART NUMBER	SECTION	LOCATION
8531-50-792	5180A -1	2 - E 4	F001-51-781	5170A -1	2 - D 4	8871-53-161	5360A -1	2 - J 4	FA48-55-231	6680A -1	2 - J 9	8001-56-051	5370A -1	2 - K 4
8871-50-825	5000A -1	2 - D 3	FA01-51-881A	6300A -1	2 - L 8	FA01-53-170B	5370A -1	2 - K 4	8118-55-232	6680A -1	2 - J 9	8545-56-052	5370A -1	2 - K 4
8871-50-825	5310A -1	2 - G 4	FA01-51-891A	6300A -1	2 - L 8	F003-53-210G	5310A -1	2 - G 4	1840-55-240	5570A -1	2 - E 5	8545-56-053	5370A -1	2 - K 4
8871-50-825	5370A -1	2 - K 4	8871-51-901C	5180A -1	2 - E 4	8545-53-225	6720A -1	2 - F10	FA01-55-251	5500A -1	2 - L 4	8973-56-065B	6330A -1	2 - M 8
FA07-50-840C	5180A -1	2 - E 4	1029-51-902	6300A -1	2 - L 8	8871-53-240A	5310A -1	2 - G 4	1316-55-261	5540A -1	2 - N 4	8973-56-066	6330A -1	2 - M 8
FA01-50-855	5180A -1	2 - E 4	8871-51-911A	5180A -1	2 - E 4	FA01-53-270A	5310A -1	2 - G 4	3625-55-261	5540A -1	2 - N 4	FA54-56-111C	5370A -1	2 - K 4
8871-50-950B	5030A -1	2 - G 3	FA01-51-930B	5103A -1	2 - K 3	8871-53-285C	5310A -1	2 - G 4	8871-55-280	5500A -1	2 - L 4	FA01-56-130	5310A -1	2 - G 4
G030-50-950	5180A -1	2 - E 4	FA01-51-931B	5103A -1	2 - K 3	FA01-53-290	5310A -1	2 - G 4	FA01-55-310	5500A -1	2 - L 4	FA01-56-140	5310A -1	2 - G 4
3958-51-021	5100A -1	2 - J 3	8871-51-932	5103A -1	2 - K 3	FA01-53-310H	5310A -1	2 - G 4	FA01-55-310 00	5500A -1	2 - L 4	8871-56-191C	5310A -1	2 - G 4
8871-51-021	5100A -1	2 - J 3	8871-51-933	5103A -1	2 - K 3	FA01-53-391B	5360A -1	2 - J 4	FA01-55-310 10	5500A -1	2 - L 4	0118-56-241	5370A -1	2 - K 4
8871-51-033	5100A -1	2 - J 3	8871-51-934	5103A -1	2 - K 3	FA01-53-400E	5310A -1	2 - G 4	FA01-55-310 29	5500A -1	2 - L 4	0118-56-241	6100A -1	2 - F 7
8572-51-051	6680A -1	2 - J 9	8871-51-935	5103A -1	2 - K 3	FA01-53-510	5310A -1	2 - G 4	FA01-55-310 70	5500A -1	2 - L 4	0118-56-241	6704A -1	2 - E10
FA01-51-061	5105A -1	2 - L 3	8871-51-936	5103A -1	2 - K 3	FA01-53-600B	5360A -1	2 - J 4	FA01-55-310 81	5500A -1	2 - L 4	0118-56-242B	5370A -1	2 - K 4
FA01-51-063	5105A -1	2 - L 3	8871-51-937	5103A -1	2 - K 3	FA01-53-700G	5360A -1	2 - J 4	FA01-55-320A	5500A -1	2 - L 4	8871-56-271E	5370A -1	2 - K 4
FA01-51-071	5105A -1	2 - L 3	8871-51-938	5103A -1	2 - K 3	FA01-53-810D	5360A -1	2 - J 4	FA01-55-320A00	5500A -1	2 - L 4	8871-56-281B	5370A -1	2 - K 4
9970-51-110	6700A -1	2 - M 9	8871-51-939	5103A -1	2 - K 3	FA01-53-900A	5360A -1	2 - J 4	FA01-55-320A10	5500A -1	2 - L 4	8871-56-281D	5370A -1	2 - K 4
9970-51-115	6700A -1	2 - M 9	FA01-51-939	5103A -1	2 - K 3	FA54-53-930	5360A -1	2 - J 4	FA01-55-320A29	5500A -1	2 - L 4	8871-56-365	5310A -1	2 - G 4
9970-51-120	6700A -1	2 - M 9	FA01-51-940B	5103A -1	2 - K 3	FA01-53-940E	5360A -1	2 - J 4	FA01-55-320A70	5500A -1	2 - L 4	8871-56-366	5310A -1	2 - G 4
FA01-51-121	5105A -1	2 - L 3	FA01-51-941B	5103A -1	2 - K 3	FA01-53-940F	5360A -1	2 - J 4	FA01-55-320A81	5500A -2	2 - M 4	8871-56-370D	5310A -1	2 - G 4
9970-51-130	6700A -1	2 - M 9	8871-51-942	5103A -1	2 - K 3	8871-53-951B	5360A -1	2 - J 4	FA01-55-330A	5560A -1	2 - C 5	FA01-56-374	1500A -2	1 - L 4
FA01-51-131	5105A -1	2 - L 3	8871-51-945	5103A -1	2 - K 3	FA01-54-170B	5370A -1	2 - K 4	FA01-55-330A00	5560A -1	2 - C 5	FA01-56-374	1500AA-1	1 - M 4
FA01-51-151D	5110A -1	2 - M 3	8871-51-951C	5180A -1	2 - E 4	F003-54-210G	5310A -1	2 - G 4	FA01-55-330A10	5560A -1	2 - C 5	8871-56-380D	5310A -1	2 - G 4
FA01-51-153A	5110A -1	2 - M 3	FA16-51-960B	5180A -1	2 - E 4	8871-54-240A	5310A -1	2 - G 4	FA01-55-330A29	5560A -1	2 - C 5	8871-56-391	5310A -1	2 - G 4
FA01-51-159	5110A -1	2 - M 3	8871-51-961A	5180A -1	2 - E 4	8871-54-260B	1850A -1	1 - M 5	FA01-55-330A70	5560A -2	2 - D 5	1480-56-410A	5370A -1	2 - K 4
FA01-51-161D	5110A -1	2 - M 3	FA16-51-962A	5180A -1	2 - E 4	FA01-54-270A	5310A -1	2 - G 4	FA01-55-330A81	5560A -2	2 - D 5	8871-56-420E	5370A -1	2 - K 4
FA01-51-163A	5110A -1	2 - M 3	FA16-51-966	5180A -1	2 - E 4	8871-54-285C	5310A -1	2 - G 4	FA01-55-340A	5560A -2	2 - D 5	1480-56-430B	5370A -1	2 - K 4
FA01-51-351A	6900A -2	2 - J11	FA01-51-980B	5310A -1	2 - G 4	FA01-54-290	5310A -1	2 - G 4	FA01-55-340A00	5560A -2	2 - D 5	1480-56-440C	5370A -1	2 - K 4
FA01-51-354	6900A -1	2 - J11	FA01-52-111D	5310A -1	2 - G 4	2113-54-295	1850A -1	1 - M 5	FA01-55-340A10	5560A -2	2 - D 5	1480-56-451B	5370A -1	2 - K 4
FA01-51-355A	6900A -1	2 - J11	FA01-52-130A	5310A -1	2 - G 4	FA01-54-310H	5310A -1	2 - G 4	FA01-55-340A29	5560A -2	2 - D 5	FA01-56-510	5360A -1	2 - J 4
FA01-51-356	6900A -1	2 - J11	8871-52-151	5310A -1	2 - G 4	8871-54-391C	5360A -1	2 - J 4	FA01-55-340A70	5560A -2	2 - D 5	FA01-56-541A	5360A -1	2 - J 4
FA01-51-357	6900A -1	2 - J11	FA01-52-211D	5310A -1	2 - G 4	FA01-54-810H	5360A -1	2 - J 4	FA01-55-340A81	5560A -2	2 - D 5	8871-56-560A	5360A -1	2 - J 4
FA01-51-358	6900A -1	2 - J11	FA01-52-230A	5310A -1	2 - G 4	8871-54-951A	5360A -1	2 - J 4	8531-55-412	5540A -1	2 - N 4	1708-56-620D	5230A -1	2 - F 4
8871-51-401	5103A -1	2 - K 3	0187-52-231	5230A -1	2 - F 4	0275-55-195A	5560A -1	2 - C 5	8871-55-420A	5540A -1	2 - N 4	0810-56-639	5370A -1	2 - K 4
3972-51-402	1320A -1	1 - K 3	0223-52-302	5230A -1	2 - F 4	FA01-55-210	5500A -1	2 - L 4	8871-55-425	5540A -1	2 - N 4	0810-56-639	6100A -1	2 - F 7
8871-51-403	5103A -1	2 - K 3	8871-52-410	5230A -1	2 - F 4	FA01-55-210 01	5500A -1	2 - L 4	F023-55-441B	5540A -1	2 - N 4	1011-56-672A	5230A -1	2 - F 4
8871-51-405	5103A -1	2 - K 3	0866-52-451	5103A -1	2 - K 3	FA02-55-210	5500A -1	2 - L 4	FA01-55-441	5540A -1	2 - N 4	8871-56-710A	5230A -1	2 - F 4
8871-51-411	5103A -1	2 - K 3	8871-52-511B	5230A -1	2 - F 4	FA02-55-210 01	5500A -1	2 - L 4	FA01-55-442	5540A -1	2 - N 4	8871-56-751A	5340A -1	2 - L 4
8871-51-421A	5103A -1	2 - K 3	8871-52-518	5230A -1	2 - F 4	FA30-55-210	5500A -1	2 - L 4	FA33-55-442	5540A -1	2 - N 4	8871-56-785	5230A -1	2 - F 4
8871-51-430C	5103A -1	2 - K 3	8871-52-810G	5310A -1	2 - G 4	FA30-55-210 01	5500A -1	2 - L 4	FA44-55-442B	5540A -1	2 - N 4	8871-56-787A	5230A -1	2 - F 4
8871-51-431	5103A -1	2 - K 3	8545-52-841	5310A -1	2 - G 4	FA42-55-210A	5500A -1	2 - L 4	FA01-55-444	5540A -1	2 - N 4	8871-56-791A	5310A -1	2 - G 4
8871-51-432	5103A -1	2 - K 3	0305-52-863B	5230A -1	2 - F 4	FA42-55-210A01	5500A -1	2 - L 4	FA01-55-446	5540A -1	2 - N 4	8871-56-792A	5310A -1	2 - G 4
8871-51-433	5103A -1	2 - K 3	9965-53-0010	3700A -1	1 - F 9	FA43-55-210A	5500A -1	2 - L 4	FA01-55-461	5540A -1	2 - N 4	8545-56-801A	5230A -1	2 - F 4
FA01-51-440	5125A -1	2 - C 4	9965-53-0015	3700A -1	1 - F 9	FA43-55-210A01	5500A -1	2 - L 4	FA01-55-471	5540A -1	2 - N 4	8545-56-801B	5230A -1	2 - F 4
FA01-51-441	5125A -1	2 - C 4	9965-53-0020	3700A -1	1 - F 9	F023-55-212	5500A -1	2 - L 4	FA33-55-471	5540A -1	2 - N 4	0820-56-905	5500A -2	2 - M 4
H001-51-511	5103A -1	2 - K 3	9965-53-0025	3700A -1	1 - F 9	FA01-55-212	5500A -1	2 - L 4	FA44-55-471A	5540A -1	2 - N 4	0820-56-905	5540A -1	2 - N 4
8545-51-516	5105A -1	2 - L 3	9965-53-0030	3700A -1	1 - F 9	8249-55-213	5500A -1	2 - L 4	FA27-55-481	5540A -1	2 - N 4	8531-56-951	3700A -2	1 - G 9
1243-51-545	5170A -1	2 - D 4	9965-53-0035	3700A -1	1 - F 9	F023-55-214	5500A -1	2 - L 4	FA01-55-482	5540A -1	2 - N 4	8871-56-970D	5370A -1	2 - K 4
FA01-51-551	5120A -1	2 - N 3	9965-53-0040	3700A -1	1 - F 9	FA01-55-215A	5500A -1	2 - L 4	FA01-55-490	5540A -1	2 - N 4	8871-56-981C	5370A -1	2 - K 4
FA01-51-561	5120A -1	2 - N 3	8871-53-041	6800A -1	2 - K10	8871-55-216	5570A -1	2 - E 5	FA01-55-492	5540A -1	2 - N 4	8871-56-990A	5370A -1	2 - K 4
8871-51-621A	5103A -1	2 - K 3	9965-53-0045	3700A -1	1 - F 9	FA01-55-216	5500A -1	2 - L 4	FA01-55-493	5540A -1	2 - N 4	0305-57-081	5700A -1	2 - H 5
8871-51-630C	5103A -1	2 - K 3	8871-53-050A	5360A -1	2 - J 4	FA01-55-221	5500A -1	2 - L 4	FA01-55-710	5500A -2	2 - M 4	0305-57-081 00	5700A -1	2 - H 5
H001-51-666	5103A -1	2 - K 3	9965-53-0050	3700A -2	1 - G 9	B001-55-225A	5500A -1	2 - L 4	FA02-55-710	5500A -2	2 - M 4	FA07-57-100A	5700AA-1	2 - C 6
H001-51-667	5103A -1	2 - K 3	9965-53-0060	3700A -2	1 - G 9	FA01-55-225	5570A -1	2 - E 5	FA01-55-811A	5540A -1	2 - N 4	FA07-57-100A01	5700AA-1	2 - C 6
8871-51-721	5170A -1	2 - D 4	FA54-53-100	5310A -1	2 - G 4	1363-55-231C	6680A -1	2 - J 9	8871-56-030A	1850A -1	1 - M 5	FA07-57-100A11	5700AA-1	2 - C 6
F001-51-771	5170A -1	2 - D 4	0187-53-134	6100A -1	2 - F 7	1363-55-231C00	6680A -1	2 - J 9	1011-56-051	5370A -1	2 - K 4	FA07-57-100A71	5700AA-1	2 - C 6

PART NUMBER INDEX

PART NUMBER	SECTION	LOCATION	PART NUMBER	SECTION	LOCATION	PART NUMBER	SECTION	LOCATION	PART NUMBER	SECTION	LOCATION	PART NUMBER	SECTION	LOCATION
FA08-57-100A	5700AA-1	2 - C 6	FA30-57-630 24	5790A -1	2 - H 6	1243-58-558	6704A -1	2 - E10	8871-59-603	5800A -1	2 - J 6	8871-61-150	6100A -1	2 - F 7
FA08-57-100A01	5700AA-1	2 - C 6	FA30-57-630 29	5790A -1	2 - H 6	1243-58-559	6704A -1	2 - E10	8871-59-760	5800A -1	2 - J 6	8871-61-181	5580A -1	2 - G 5
FA08-57-100A71	5700AA-1	2 - C 6	8872-57-633	5790A -1	2 - H 6	8871-58-560A	5830A -1	2 - K 6	8871-60-050A	5500A -2	2 - M 4	8871-61-182	5580A -1	2 - G 5
FA09-57-100A	5700AA-1	2 - C 6	8872-57-670A	5790A -1	2 - H 6	FA02-58-560	5830A -1	2 - K 6	0305-60-052A	5500A -2	2 - M 4	8871-61-183A	5580A -1	2 - G 5
FA09-57-100A01	5700AA-1	2 - C 6	8872-57-670A00	5790A -1	2 - H 6	8038-58-580A	5830A -1	2 - K 6	8871-60-070B	5540A -1	2 - N 4	8871-61-184A	5580A -1	2 - G 5
FA09-57-100A11	5700AA-1	2 - C 6	8872-57-670A12	5790A -1	2 - H 6	8038-58-580A02	5830A -1	2 - K 6	8871-60-121	5580A -1	2 - G 5	FA01-61-190	6100A -1	2 - F 7
FA09-57-100A71	5700AA-1	2 - C 6	8872-57-670A24	5790A -1	2 - H 6	8038-58-580A12	5830A -1	2 - K 6	8871-60-141	5580A -1	2 - G 5	FA01-61-190A	6100A -1	2 - F 7
FA82-57-100	5700AA-1	2 - C 6	8872-57-670B	5790A -1	2 - H 6	8038-58-580A27	5830A -1	2 - K 6	FA01-60-220	5500A -2	2 - M 4	8171-61-191A	6100A -1	2 - F 7
FA82-57-100 10	5700AA-1	2 - C 6	3872-57-670B00	5790A -1	2 - H 6	8038-58-580A29	5830A -1	2 - K 6	FA01-60-230	5500A -2	2 - M 4	8563-61-196A	6100A -1	2 - F 7
FA82-57-100 29	5700AA-1	2 - C 6	8872-57-670B12	5790A -1	2 - H 6	G018-58-580	5830A -2	2 - L 6	FA01-60-241	5500A -2	2 - M 4	8563-61-197B	6100A -1	2 - F 7
FA82-57-100 70	5700AA-1	2 - C 6	8872-57-670B24	5790A -1	2 - H 6	G019-58-580	5830A -2	2 - L 6	FA01-60-242	5500A -2	2 - M 4	8171-61-212	6100A -1	2 - F 7
2155-57-109	5700A -1	2 - H 5	FA30-57-670	5790A -1	2 - H 6	8037-58-585	5830A -2	2 - L 6	G001-60-261	5500A -2	2 - M 4	8871-61-213	6100A -1	2 - F 7
2155-57-109	5700AA-1	2 - C 6	FA30-57-670 00	5790A -1	2 - H 6	8037-58-585 02	5830A -2	2 - L 6	FA01-60-350A	5560A -1	2 - C 5	FA42-61-213A	6100A -1	2 - F 7
FA07-57-150A	5700AA-1	2 - C 6	FA30-57-670 12	5790A -1	2 - H 6	8037-58-585 12	5830A -2	2 - L 6	FA01-60-350A00	5560A -1	2 - C 5	1011-61-216	6100A -1	2 - F 7
FA07-57-150A01	5700AA-1	2 - C 6	FA30-57-670 24	5790A -2	2 - I 6	8037-58-585 27	5830A -2	2 - L 6	FA01-60-350A10	5560A -1	2 - C 5	8871-61-219A	6100A -1	2 - F 7
FA07-57-150A11	5700AA-1	2 - C 6	FA30-57-670 29	5790A -2	2 - I 6	8037-58-585 29	5830A -2	2 - L 6	FA01-60-350A70	5560A -1	2 - C 5	F001-61-220B	6100A -1	2 - F 7
FA07-57-150A71	5700AA-1	2 - C 6	8872-57-680A	5790A -2	2 - I 6	FA02-58-590	5830A -1	2 - K 6	FA01-60-350B	5560A -1	2 - C 5	FA42-61-220C	6100A -1	2 - F 7
FA08-57-150A	5700AA-1	2 - C 6	8872-57-680A00	5790A -2	2 - I 6	8871-58-603	5800A -1	2 - J 6	FA01-60-350B00	5560A -1	2 - C 5	8871-61-230	6100A -1	2 - F 7
FA08-57-150A01	5700AA-1	2 - C 6	8872-57-680A12	5790A -2	2 - I 6	8871-58-605C	5800A -1	2 - J 6	FA01-60-350B10	5560A -1	2 - C 5	8871-61-251A	5580A -1	2 - G 5
FA08-57-150A71	5700AA-1	2 - C 6	8872-57-680A24	5790A -2	2 - I 6	0259-58-612	5560A -2	2 - D 5	FA01-60-350B29	5560A -1	2 - C 5	0222-61-622	5370A -1	2 - K 4
FA09-57-150A	5700AA-1	2 - C 6	FA30-57-680	5790A -2	2 - I 6	8871-58-760	5800A -1	2 - J 6	FA01-60-350B70	5560A -1	2 - C 5	9960-62-202	1830A -1	1 - J 5
FA09-57-150A01	5700AA-1	2 - C 6	FA30-57-680 00	5790A -2	2 - I 6	0305-58-762	5800A -1	2 - J 6	FA01-60-350B81	5560A -1	2 - C 5	8871-62-210B	6230A -1	2 - K 8
FA09-57-150A11	5700AA-1	2 - C 6	FA30-57-680 12	5790A -2	2 - I 6	8871-58-781	5840A -1	2 - C 7	FA01-60-400F	5560A -1	2 - C 5	8871-62-231	6230A -1	2 - K 8
FA09-57-150A71	5700AA-1	2 - C 6	FA30-57-680 24	5790A -2	2 - I 6	8871-58-791	5840A -1	2 - C 7	9923-60-571	1100A -1	1 - G 3	8871-62-232A	6230A -1	2 - K 8
FA82-57-150	5700AA-1	2 - C 6	FA30-57-680 29	5790A -2	2 - I 6	0559-58-868	4000A -2	1 - J 9	0305-60-690	5560A -1	2 - C 5	8871-62-233	6230A -1	2 - K 8
FA82-57-150 10	5700AA-1	2 - C 6	FA30-57-680 75	5790A -2	2 - I 6	0259-58-906	5830A -2	2 - L 6	0305-60-690	6230A -1	2 - K 8	8871-62-241A	6230A -1	2 - K 8
FA82-57-150 29	5700AA-1	2 - C 6	FA54-58-010H	5800A -1	2 - J 6	0208-58-921	5840A -1	2 - C 7	8871-60-701	5560A -1	2 - C 5	FA01-62-310C	6230A -1	2 - K 8
FA82-57-150 70	5700AA-1	2 - C 6	8981-58-020E	5800A -1	2 - J 6	0208-58-921	6840A -1	2 - C11	8871-60-701 00	5560A -1	2 - C 5	FA02-62-310B	6230A -1	2 - K 8
0286-57-318	5800A -1	2 - J 6	8871-58-210	5830A -1	2 - K 6	0187-58-922	5840A -1	2 - C 7	8871-60-701 11	5560A -1	2 - C 5	8341-62-315	6230A -1	2 - K 8
8872-57-610A	5790A -1	2 - H 6	1011-58-231	5830A -1	2 - K 6	0223-58-961	0900A -1	2 - C 3	8871-60-701 28	5560A -1	2 - C 5	8871-62-361	6230A -1	2 - K 8
8872-57-610A00	5790A -1	2 - H 6	8531-58-231A	5830A -1	2 - K 6	0223-58-961	0900A -1	2 - C 3	8871-60-701 71	5560A -1	2 - C 5	FA01-62-365	6230A -1	2 - K 8
8872-57-610A12	5790A -1	2 - H 6	8032-58-240	5830A -1	2 - K 6	0223-58-962	0900A -1	2 - C 3	8871-60-701 75	5560A -1	2 - C 5	FA01-62-366	6230A -1	2 - K 8
8872-57-610A24	5790A -1	2 - H 6	8116-58-303	5830A -1	2 - K 6	9965-59-0010	3700A -2	1 - G 9	8871-60-702	5560A -1	2 - C 5	8871-62-367	6230A -1	2 - K 8
8872-57-610B	5790A -1	2 - H 6	8116-58-303 00	5830A -1	2 - K 6	FA54-59-010H	5800A -1	2 - J 6	8341-60-710A	5560A -1	2 - C 5	8001-62-495	0900A -1	2 - C 3
8872-57-610B00	5790A -1	2 - H 6	8116-58-303 12	5830A -1	2 - K 6	9965-59-0015	3700A -2	1 - G 9	8341-60-710A00	5560A -1	2 - C 5	8871-62-621	6230A -1	2 - K 8
8872-57-610B12	5790A -1	2 - H 6	8116-58-303 27	5830A -1	2 - K 6	8871-59-020E	5800A -1	2 - J 6	8341-60-710A01	5560A -1	2 - C 5	8871-62-631	6230A -1	2 - K 8
8872-57-610B24	5790A -1	2 - H 6	8116-58-303 29	5830A -1	2 - K 6	9965-59-0020	3700A -2	1 - G 9	8341-60-710A10	5560A -1	2 - C 5	8871-62-635A	6230A -1	2 - K 8
FA30-57-610	5790A -1	2 - H 6	0259-58-305B	5830A -1	2 - K 6	9965-59-0025	3700A -2	1 - G 9	8341-60-710A28	5560A -1	2 - C 5	8871-62-635A	6750A -1	2 - I10
FA30-57-610 00	5790A -1	2 - H 6	0305-58-309	5830A -1	2 - K 6	9965-59-0030	3700A -2	1 - G 9	8341-60-710A29	5560A -1	2 - C 5	8871-62-636A	6230A -1	2 - K 8
FA30-57-610 12	5790A -1	2 - H 6	8871-58-310E	5830A -1	2 - K 6	9965-59-0035	3700A -2	1 - G 9	8341-60-710A81	5560A -1	2 - C 5	8871-62-636A	6750A -1	2 - I10
FA30-57-610 24	5790A -1	2 - H 6	F023-58-310	5830A -1	2 - K 6	9965-59-0040	3700A -2	1 - G 9	8562-60-712	5560A -1	2 - C 5	8871-62-637	6230A -1	2 - K 8
FA30-57-610 29	5790A -1	2 - H 6	1243-58-314	5830A -1	2 - K 6	9965-59-0045	3700A -2	1 - G 9	8341-60-713	5560A -1	2 - C 5	8871-62-761D	6300A -1	2 - L 8
8872-57-620A	5790A -1	2 - H 6	G030-58-315	6230A -1	2 - K 8	9965-59-0050	3700A -2	1 - G 9	8341-60-713 01	5560A -1	2 - C 5	8346-62-801C	6330A -1	2 - M 8
8872-57-620A00	5790A -1	2 - H 6	G030-58-316A	5830A -2	2 - L 6	9965-59-0060	3700A -2	1 - G 9	8341-60-713 10	5560A -1	2 - C 5	8346-62-801C02	6330A -1	2 - M 8
8872-57-620A12	5790A -1	2 - H 6	G030-58-316A00	5830A -2	2 - L 6	8871-59-210	5830A -1	2 - K 6	8341-60-713 28	5560A -1	2 - C 5	8346-62-801C11	6330A -1	2 - M 8
8872-57-620A24	5790A -1	2 - H 6	8545-58-330	5830A -1	2 - K 6	8531-59-240A	5830A -1	2 - K 6	8341-60-713 29	5560A -1	2 - C 5	8346-62-801C29	6330A -1	2 - M 8
FA30-57-620	5790A -1	2 - H 6	8531-58-361	5830A -1	2 - K 6	8871-59-310E	5830A -1	2 - K 6	8341-60-713 81	5560A -1	2 - C 5	8346-62-801C70	6330A -1	2 - M 8
FA30-57-620 00	5790A -1	2 - H 6	0223-58-375A	5830A -1	2 - K 6	F023-59-310	5830A -1	2 - K 6	FA01-60-960A	4200A -1	1 - M 9	8970-62-805B	6330A -1	2 - M 8
FA30-57-620 12	5790A -1	2 - H 6	0223-58-375A00	5830A -1	2 - K 6	8871-59-410C	5830A -1	2 - K 6	8871-60-962A	4200A -1	1 - M 9	8970-62-815B	6330A -1	2 - M 8
FA30-57-620 24	5790A -1	2 - H 6	0223-58-375A12	5830A -1	2 - K 6	8871-59-501E	5800A -1	2 - J 6	9963-60-4130	3700A -1	1 - F 9	8346-62-820A	6330A -1	2 - M 8
FA30-57-620 29	5790A -1	2 - H 6	0223-58-375A27	5830A -1	2 - K 6	8871-59-560A	5830A -1	2 - K 6	9958-60-8166	1700A -1	1 - D 5	8499-62-868	6100A -1	2 - F 7
FA30-57-620 75	5790A -1	2 - H 6	0223-58-375A29	5830A -1	2 - K 6	FA02-59-560	5830A -1	2 - K 6	9958-60-8166	1920A -1	1 - C 6	8346-62-871A	6330A -1	2 - M 8
FA30-57-630	5790A -1	2 - H 6	8871-58-410C	5830A -1	2 - K 6	G018-59-580	5830A -1	2 - K 6	1708-61-031	6100A -1	2 - F 7	8346-62-875A	6330A -1	2 - M 8
FA30-57-630 00	5790A -1	2 - H 6	1243-58-411	5830A -1	2 - K 6	G019-59-580	5830A -2	2 - L 6	FA42-61-130	6100A -1	2 - F 7	8346-62-876	6330A -1	2 - M 8
FA30-57-630 12	5790A -1	2 - H 6	8871-58-501E	5800A -1	2 - J 6	FA02-59-590	5830A -1	2 - K 6	8871-61-140A	6100A -1	2 - F 7	8346-62-878A	6330A -1	2 - M 8

PART NUMBER INDEX

PART NUMBER	SECTION	LOCATION	PART NUMBER	SECTION	LOCATION	PART NUMBER	SECTION	LOCATION	PART NUMBER	SECTION	LOCATION	PART NUMBER	SECTION	LOCATION
0633-62-879	5560A -2	2 - D 5	FA01-64-320B10	5570A -1	2 - E 5	8570-64-815B	5580A -1	2 - G 5	FA01-66-630	6610A -1	2 - C 9	0000-67-0007-41	6152A -1	2 - H 8
8346-62-879	6330A -1	2 - M 8	FA01-64-320B29	5570A -1	2 - E 5	8871-64-820	5580A -1	2 - G 5	FA01-66-670	6610A -1	2 - C 9	0000-67-0007-41	6152AB-1	2 - I 8
FA04-62-881A	6330A -1	2 - M 8	FA01-64-320B70	5570A -1	2 - E 5	8341-64-825	5580A -1	2 - G 5	FA01-66-700	6610A -1	2 - C 9	0000-67-0007-37	6152AB-1	2 - I 8
FA04-62-881A00	6330A -1	2 - M 8	FA01-64-320B81	5570A -1	2 - E 5	8871-64-901	5570A -2	2 - F 5	FA01-66-730B	6700A -1	2 - M 9	0000-67-0007-42	6152AB-1	2 - I 8
FA04-62-881A11	6330A -1	2 - M 8	FA01-64-350A	5570A -1	2 - E 5	8871-64-901 00	5570A -2	2 - F 5	FA01-66-731	6700A -1	2 - M 9	0000-67-0007-41	6152AC-1	2 - J 8
FA04-62-881A29	6330A -1	2 - M 8	FA01-64-350A01	5570A -1	2 - E 5	8871-64-901 11	5570A -2	2 - F 5	FA01-66-731B	6700A -1	2 - M 9	0000-67-0007-42	6152AC-1	2 - J 8
FA04-62-881A70	6330A -1	2 - M 8	FA03-64-350	5570A -1	2 - E 5	8871-64-901 70	5570A -2	2 - F 5	FA01-66-731B	6700A -1	2 - M 9	0000-67-0007-37	6152AC-1	2 - J 8
8346-62-882	6330A -1	2 - M 8	FA03-64-350 01	5570A -1	2 - E 5	8871-64-901 71	5570A -2	2 - F 5	FA01-66-732	6700A -1	2 - M 9	0000-67-0008-79	6152A -1	2 - H 8
8346-62-883	6330A -1	2 - M 8	FA01-64-351A	5570A -1	2 - E 5	8871-64-901 75	5570A -2	2 - F 5	FA01-66-732B	6700A -1	2 - M 9	0000-67-0008-79	6152AB-1	2 - I 8
8346-62-885	6330A -1	2 - M 8	FA01-64-351A01	5570A -1	2 - E 5	0613-65-857A	1850A -1	1 - M 5	FA01-66-732B	6700A -1	2 - M 9	0000-67-0010-64	6152A -1	2 - H 8
FA01-62-950D	6300A -1	2 - L 8	8871-64-370A	5570A -1	2 - E 5	0483-66-061A	5100A -1	2 - J 3	8871-66-760	6700A -1	2 - M 9	0000-67-0010-63	6152A -1	2 - H 8
8871-62-960A	6300A -1	2 - L 8	FA01-64-381	5570A -1	2 - E 5	FA01-66-120	6611A -1	2 - D 9	8572-66-771	6635A -1	2 - H 9	0000-67-0010-64	6152AB-1	2 - I 8
8871-62-966A	6300A -1	2 - L 8	FA01-64-410C	5570A -2	2 - F 5	FA02-66-120	6611A -1	2 - D 9	3874-66-780	6635A -1	2 - H 9	0000-67-0010-63	6152AB-1	2 - I 8
FA01-62-970	6300A -1	2 - L 8	FA01-64-410C00	5570A -2	2 - F 5	FA01-66-122	6611A -1	2 - D 9	3874-66-790	6635A -1	2 - H 9	0000-67-0010-63	6152AC-1	2 - J 8
8346-62-980	6330A -1	2 - M 8	FA01-64-410C10	5570A -2	2 - F 5	BA30-66-123	6611A -1	2 - D 9	1524-66-810B	6630A -1	2 - G 9	0000-67-0010-64	6152AC-1	2 - J 8
8871-63-210B	6230A -1	2 - K 8	FA01-64-410C29	5570A -2	2 - F 5	8182-66-124	6611A -1	2 - D 9	FA01-66-810A	6630A -1	2 - G 9	FA01-67-010E	6700A -1	2 - M 9
8871-63-231	6230A -1	2 - K 8	FA01-64-410C70	5570A -2	2 - F 5	BA29-66-126	6611A -1	2 - D 9	FA03-66-820B	6630A -1	2 - G 9	FA30-67-010D	6700A -1	2 - M 9
8871-63-241A	6230A -1	2 - K 8	FA01-64-410C81	5570A -2	2 - F 5	8182-66-127	6611A -1	2 - D 9	0209-66-821	6620A -1	2 - F 9	FA42-67-010A	6700A -1	2 - M 9
8346-63-875A	6330A -1	2 - M 8	FA02-64-411	5570A -2	2 - F 5	FA02-66-128	6611A -1	2 - D 9	0222-66-865A	6680A -1	2 - J 9	0000-67-0011-62	6132A -1	2 - J 7
8346-63-876	6330A -1	2 - M 8	FA02-64-411 00	5570A -2	2 - F 5	BA29-66-129	6611A -1	2 - D 9	0222-66-865A00	6680A -1	2 - J 9	0000-67-0011-83	6132A -1	2 - J 7
FA01-63-901B	6300A -1	2 - L 8	FA02-64-411 10	5570A -2	2 - F 5	8218-66-143	0900A -1	2 - C 3	0710-66-868A	6680A -3	2 - L 9	0000-67-0011-62	6132AB-1	2 - L 7
FA02-63-901F	6300A -1	2 - L 8	FA02-64-411 29	5570A -2	2 - F 5	BA14-66-151A	0900A -1	2 - C 3	FA07-66-890	6610A -1	2 - C 9	0000-67-0011-61	6132AB-1	2 - L 7
1243-63-902	6300A -1	2 - L 8	FA02-64-411 70	5570A -2	2 - F 5	H043-66-154	0900A -1	2 - C 3	FA10-66-900	6680A -2	2 - K 9	0000-67-0011-83	6132AB-1	2 - L 7
8871-63-911	6300A -1	2 - L 8	FA02-64-411 81	5570A -2	2 - F 5	BA24-66-155A	0900A -1	2 - C 3	FA05-66-910A	6680A -1	2 - J 9	0000-67-0011-62	6132AC-1	2 - C 8
8871-63-935A	6300A -1	2 - L 8	8871-64-412	5570A -2	2 - F 5	BA14-66-156	0900A -1	2 - C 3	FA09-66-910A	6680A -1	2 - J 9	0000-67-0011-61	6132AC-1	2 - C 8
8871-63-942	6300A -1	2 - L 8	FA01-64-413A	5570A -2	2 - F 5	FA01-66-241	6610A -1	2 - C 9	FA45-66-910	6680A -1	2 - J 9	0000-67-0011-83	6132AC-2	2 - D 8
FA01-63-950D	6300A -1	2 - L 8	8871-64-415	5570A -1	2 - E 5	8871-66-242	6610A -1	2 - C 9	FA01-66-930C	6680A -2	2 - K 9	0000-67-0012-72	6132AC-1	2 - C 8
8871-63-960A	6300A -1	2 - L 8	FA01-64-420B	5570A -2	2 - F 5	FA01-66-250	6610A -1	2 - C 9	FA42-66-930A	6680A -2	2 - K 9	FA01-67-030C	6702A -1	2 - C10
FA01-63-970	6300A -1	2 - L 8	FA01-64-420B00	5570A -2	2 - F 5	8182-66-251	6610A -1	2 - C 9	8869-66-936A	6680A -2	2 - K 9	8871-67-031	6704A -1	2 - E10
FA01-64-030	5560A -2	2 - D 5	FA01-64-420B10	5570A -2	2 - F 5	FA01-66-251	6610A -1	2 - C 9	FA01-66-941A	6680A -2	2 - K 9	FA01-67-050D	6700A -1	2 - M 9
FA01-64-030 00	5560A -2	2 - D 5	FA01-64-420B29	5570A -2	2 - F 5	FA43-66-310B	6640A -1	2 - I 9	FA02-66-941	6680A -1	2 - J 9	1480-67-051B	6700A -1	2 - M 9
FA01-64-030 10	5560A -2	2 - D 5	FA01-64-420B70	5570A -2	2 - F 5	FA03-66-311	6640A -1	2 - I 9	FA42-66-941A	6680A -2	2 - K 9	8341-67-051A	6700A -1	2 - M 9
FA01-64-030 29	5560A -2	2 - D 5	FA01-64-420B81	5570A -2	2 - F 5	FA43-66-311	6640A -1	2 - I 9	FA02-66-942	6680A -1	2 - J 9	8341-67-051A	6700A -1	2 - M 9
FA01-64-030 70	5560A -2	2 - D 5	8871-64-430A	5570A -2	2 - F 5	FA03-66-312	6640A -1	2 - I 9	FA43-66-942	6680A -1	2 - J 9	0000-67-0052-34	6142A -1	2 - E 8
FA01-64-030 81	5560A -2	2 - D 5	FA01-64-430	5570A -2	2 - F 5	FA43-66-315	6640A -1	2 - I 9	0208-66-944A	6730A -1	2 - G10	W023-67-056	5010A -1	2 - F 3
8871-64-043	5560A -2	2 - D 5	FA01-64-451	5570A -1	2 - E 5	FA02-66-320B	6640A -1	2 - I 9	FA01-66-944	6680A -2	2 - K 9	W023-67-056	5310A -1	2 - G 4
8871-64-050A	5560A -2	2 - D 5	FA01-64-451 01	5570A -1	2 - E 5	FA30-66-320B	6640A -1	2 - I 9	FA42-66-945	6680A -2	2 - K 9	G001-67-061	5500A -2	2 - M 4
8871-64-101	5560A -2	2 - D 5	FA02-64-451	5570A -1	2 - E 5	GA03-66-330A	6640A -1	2 - I 9	FA01-66-946	6680A -2	2 - K 9	0000-67-0070-99	6142A -1	2 - E 8
8871-64-161B	5560A -2	2 - D 5	FA02-64-451 01	5570A -1	2 - E 5	FA03-66-340	6610A -1	2 - C 9	FA01-66-947	6680A -2	2 - K 9	0000-67-0070-88	6142A -1	2 - E 8
8871-64-162A	5560A -2	2 - D 5	1011-64-461A	6900A -1	2 - I11	FA03-66-350A	6615A -1	2 - E 9	FA01-66-948	6680A -2	2 - K 9	FA01-67-090B	6701A -1	2 - N 9
FA01-64-221	5570A -1	2 - E 5	1011-64-461A00	6900A -1	2 - I11	FA02-66-361	6640A -1	2 - I 9	8980-66-961	6680A -2	2 - K 9	FA03-67-090C	6701A -1	2 - N 9
FA01-64-221 00	5570A -1	2 - E 5	FA01-64-491	5570A -2	2 - F 5	FA43-66-361A	6640A -1	2 - I 9	FA05-66-970B	6680A -2	2 - K 9	3777-67-099	6700A -1	2 - M 9
FA01-64-221 10	5570A -1	2 - E 5	FA01-64-492	5570A -2	2 - F 5	FA43-66-365	6640A -1	2 - I 9	FA07-66-970	6680A -2	2 - K 9	8871-67-099	6700A -1	2 - M 9
FA01-64-221 29	5570A -1	2 - E 5	FA01-64-494	5570A -1	2 - E 5	0212-66-371	6750A -1	2 - I10	FA09-66-970A	6680A -2	2 - K 9	FA02-67-099	6700A -1	2 - M 9
FA01-64-221 70	5570A -1	2 - E 5	FA01-64-610	5500A -2	2 - M 4	3874-66-371	5120A -1	2 - N 3	0222-66-971	5370A -1	2 - K 4	FA01-67-120B	6703A -1	2 - D10
FA01-64-221 81	5570A -1	2 - E 5	FA01-64-610 00	5500A -2	2 - M 4	0212-66-372A	6750A -1	2 - I10	1247-66-980	6680A -2	2 - K 9	FA03-67-120B	6702A -1	2 - C10
FA01-64-222	5570A -1	2 - E 5	FA01-64-630	5500A -2	2 - M 4	3874-66-373	5120A -1	2 - N 3	FA07-66-980	6840A -1	2 - C11	0000-67-0121-39	6142AB-1	2 - F 8
FA01-64-222 00	5570A -1	2 - E 5	FA01-64-630 00	5500A -2	2 - M 4	B001-66-422	6610A -1	2 - C 9	0000-67-0000-33	6132A -1	2 - J 7	0000-67-0123-38	6132AB-2	2 - M 7
FA01-64-222 10	5570A -1	2 - E 5	8871-64-750A	5580A -1	2 - G 5	8871-66-450	6620A -1	2 - F 9	0000-67-0007-45	6132A -1	2 - J 7	0000-67-0123-38	6132AC-1	2 - C 8
FA01-64-222 29	5570A -1	2 - E 5	8871-64-761	5580A -1	2 - G 5	B001-66-460	6610A -1	2 - C 9	0000-67-0007-44	6132A -1	2 - J 7	0000-67-0123-40	6142A -1	2 - E 8
FA01-64-222 70	5570A -1	2 - E 5	8871-64-771A	5580A -1	2 - G 5	B001-66-490A	4300A -1	1 - N 9	0000-67-0007-45	6132AB-1	2 - L 7	0000-67-0123-40	6142AB-1	2 - F 8
FA01-64-222 81	5570A -1	2 - E 5	8871-64-773	5580A -1	2 - G 5	B001-66-490A	4300A -1	1 - N 9	0000-67-0007-44	6132AB-1	2 - L 7	0000-67-0123-40	6142AC-1	2 - G 8
FA01-64-225	5570A -1	2 - E 5	8871-64-780B	5580A -1	2 - G 5	B001-66-540	6620A -1	2 - F 9	0000-67-0007-47	6132AB-1	2 - L 7	0000-67-0123-21	6152AB-1	2 - I 8
FA01-64-320B	5570A -1	2 - E 5	8871-64-811A	5580A -1	2 - G 5	0305-66-580A	5570A -1	2 - E 5	0000-67-0007-37	6152A -1	2 - H 8	0000-67-0123-21	6152AC-1	2 - J 8
FA01-64-320B00	5570A -1	2 - E 5	8871-64-812	5580A -1	2 - G 5	FA02-66-600A	6900A -2	2 - J11	0000-67-0007-42	6152A -1	2 - H 8	0000-67-0123-18	6152AC-1	2 - J 8

PART NUMBER INDEX

PART NUMBER	SECTION	LOCATION	PART NUMBER	SECTION	LOCATION	PART NUMBER	SECTION	LOCATION	PART NUMBER	SECTION	LOCATION	PART NUMBER	SECTION	LOCATION
0000-67-0124-26	6142AB-1	2 - F 8	1480-67-510	6750A -1	2 - I10	0000-67-B44A-3B	6152AC-1	2 - J 8	0000-67-X40M-03	6132AC-1	2 - C 8	0000-67-1981-79	6142AB-1	2 - F 8
0000-67-0124-26	6142AC-1	2 - G 8	1011-67-511B	6720A -1	2 - F10	0000-67-B62A-4A	6152A -1	2 - H 8	0000-67-X40M-04	6132AC-1	2 - C 8	0000-67-1981-79	6142AC-1	2 - G 8
0000-67-0127-10	6142A -1	2 - E 8	1011-67-515B	6720A -1	2 - F10	0000-67-B62A-4A	6152AB-1	2 - I 8	0000-67-X40M-03	6142AB-1	2 - F 8	0000-67-1981-03	6152A -1	2 - H 8
0000-67-0127-08	6142AB-1	2 - F 8	1410-67-530	6750A -1	2 - I10	0000-67-B62A-4A	6152AC-1	2 - J 8	0000-67-X40M-03	6142AC-1	2 - G 8	0000-67-1981-40	6152A -1	2 - H 8
0000-67-0127-16	6142AB-1	2 - F 8	FA02-67-540	6610A -1	2 - C 9	0000-67-B82A-6P	6152AB-1	2 - I 8	0000-67-X60A-00	6132A -1	2 - J 7	0000-67-1981-03	6152AB-1	2 - I 8
0000-67-0127-08	6142AC-1	2 - G 8	FA02-67-560	6630A -1	2 - G 9	0000-67-B82A-6P	6152AC-1	2 - J 8	0000-67-X60A-00	6132AB-1	2 - L 7	0000-67-1981-40	6152AB-1	2 - I 8
0866-67-156	6720A -1	2 - F10	FA03-67-560	6630A -1	2 - G 9	0000-67-C00A-4A	6142AB-1	2 - F 8	0000-67-X60A-00	6132AC-1	2 - C 8	0000-67-1981-40	6152AC-1	2 - J 8
FA02-67-190A	6703A -1	2 - D10	8545-67-568	6630A -1	2 - G 9	0000-67-C00A-4A	6142AC-1	2 - G 8	0000-67-1265-57	6132A -1	2 - J 7	0000-67-1981-03	6152AC-1	2 - J 8
0000-67-0229-37	6142A -1	2 - E 8	FA02-67-571	6630A -1	2 - G 9	0000-67-C10A-4A	6142AB-1	2 - F 8	0000-67-1285-08	6132AB-1	2 - L 7	0000-67-1982-33	6132A -1	2 - J 7
0000-67-0229-58	6142AB-1	2 - F 8	FA02-67-572	6630A -1	2 - G 9	0000-67-C10A-4A	6142AC-1	2 - G 8	0000-67-1285-08	6132AC-1	2 - C 8	0000-67-1982-33	6132AB-1	2 - L 7
0000-67-0232-37	6142A -1	2 - E 8	FA02-67-573	6630A -1	2 - G 9	0000-67-C21A-4A	6142AB-1	2 - F 8	0000-67-1410-13	6142A -1	2 - E 8	0000-67-1982-33	6132AC-1	2 - C 8
0000-67-0232-43	6142AB-1	2 - F 8	FA02-67-574	6630A -1	2 - G 9	0000-67-C21A-4A	6142AC-1	2 - G 8	0000-67-1477-21	6132A -1	2 - J 7	0000-67-1982-40	6142A -1	2 - E 8
0000-67-0233-37	6142A -1	2 - E 8	FA02-67-577	6630A -1	2 - G 9	0000-67-C22A-4A	6142AB-1	2 - F 8	0000-67-1478-05	6132AB-1	2 - L 7	0000-67-1982-26	6152A -1	2 - H 8
0000-67-0233-15	6142AB-1	2 - F 8	1480-67-606	6750A -1	2 - I10	0000-67-C22A-4A	6142AC-1	2 - G 8	0000-67-1478-35	6132AC-1	2 - C 8	0000-67-1982-26	6152AB-1	2 - I 8
0000-67-0234-00	6142AB-1	2 - F 8	0000-67-0651-48	6132A -1	2 - J 7	0000-67-C31A-6A	6142A -1	2 - E 8	0000-67-1478-36	6152A -1	2 - H 8	0000-67-1982-26	6152AC-1	2 - J 8
8871-67-242	6700A -1	2 - M 9	0000-67-0651-49	6132A -1	2 - J 7	0000-67-D00B-3A	6142AB-1	2 - F 8	0000-67-1478-36	6152AB-1	2 - I 8	0000-67-1983-82	6132AB-1	2 - L 7
FA01-67-242	6680A -2	2 - K 9	0000-67-0651-47	6132A -1	2 - J 7	0000-67-D00B-3A	6142AC-1	2 - G 8	0000-67-1478-36	6152AC-1	2 - J 8	0000-67-1983-82	6132AC-1	2 - C 8
8871-67-250A	1850A -1	1 - M 5	0000-67-0651-46	6132A -1	2 - J 7	0000-67-D10A-3A	6142AC-1	2 - G 8	0000-67-1970-62	6132A -1	2 - J 7	0000-67-1983-76	6142A -1	2 - E 8
8872-67-250B	1850A -1	1 - M 5	0000-67-0652-70	6132AB-1	2 - L 7	0000-67-D11A-6A	6142A -1	2 - E 8	0000-67-1970-27	6132AB-1	2 - L 7	0000-67-1983-71	6142A -1	2 - E 8
8871-67-260A	1850A -1	1 - M 5	0000-67-0652-71	6132AB-1	2 - L 7	0000-67-D11A-3A	6142AC-1	2 - G 8	0000-67-1970-27	6132AC-2	2 - D 8	0000-67-1983-77	6142A -1	2 - E 8
1011-67-291A	1850A -1	1 - M 5	0000-67-0652-71	6132AC-2	2 - D 8	0000-67-D12A-3B	6142A -1	2 - E 8	0000-67-1970-62	6132AC-1	2 - C 8	0000-67-1983-75	6142A -1	2 - E 8
1011-67-293	1850A -1	1 - M 5	0000-67-0652-70	6132AC-2	2 - D 8	0000-67-D13B-3B	6142A -1	2 - E 8	0000-67-1970-63	6132AC-1	2 - C 8	0000-67-1983-70	6142A -1	2 - E 8
0866-67-301A	6730A -1	2 - G10	BE32-67-680A	6630A -1	2 - G 9	0000-67-D13B-3B	6142AB-1	2 - F 8	0000-67-1976-92	6142AB-1	2 - F 8	0000-67-1983-70	6142AB-1	2 - F 8
0866-67-302	6730A -1	2 - G10	FA30-67-690	6630A -1	2 - G 9	0000-67-D13B-3B	6142AC-1	2 - G 8	0000-67-1976-92	6142AC-1	2 - G 8	0000-67-1983-77	6142AB-1	2 - F 8
8872-67-321	6730A -1	2 - G10	FA30-67-690A	6630A -1	2 - G 9	0000-67-D14B-3B	6142A -1	2 - E 8	0000-67-1977-99	6132A -2	2 - K 7	0000-67-1983-69	6142AB-1	2 - F 8
8144-67-330A	6750A -1	2 - I10	0866-67-717	6630A -1	2 - G 9	0000-67-D14B-3B	6142AB-1	2 - F 8	0000-67-1977-07	6132A -1	2 - J 7	0000-67-1983-76	6142AB-1	2 - F 8
8562-67-330A	6730A -1	2 - G10	1480-67-740	6630A -1	2 - G 9	0000-67-D14B-3B	6142AC-1	2 - G 8	0000-67-1977-89	6132A -2	2 - K 7	0000-67-1983-70	6142AC-1	2 - G 8
FA42-67-330	6730A -1	2 - G10	8173-67-740A	6630A -1	2 - G 9	0000-67-D16A-3A	6142AC-1	2 - G 8	0000-67-1977-09	6132A -2	2 - K 7	0000-67-1983-77	6142AC-1	2 - G 8
0000-67-0336-80	6152A -1	2 - H 8	FA01-67-740	6630A -1	2 - G 9	0000-67-D17A-3A	6142AC-1	2 - G 8	0000-67-1977-09	6132AB-1	2 - L 7	0000-67-1983-76	6142AC-1	2 - G 8
0000-67-0336-81	6152AB-1	2 - I 8	0000-67-0957-22	6152A -1	2 - H 8	0000-67-D18A-3A	6142AC-1	2 - G 8	0000-67-1977-99	6132AB-1	2 - L 7	0000-67-1983-69	6142AC-1	2 - G 8
0000-67-0336-81	6152AC-1	2 - J 8	0000-67-0958-17	6152A -1	2 - H 8	0000-67-D19A-3A	6142AC-1	2 - G 8	0000-67-1977-89	6132AB-1	2 - L 7	0000-67-1983-78	6152A -1	2 - H 8
8872-67-350A	6730A -1	2 - G10	0000-67-0958-17	6152AB-1	2 - I 8	0000-67-D20A-3A	6142AC-1	2 - G 8	0000-67-1977-07	6132AB-1	2 - L 7	0000-67-1983-78	6152AB-1	2 - I 8
8871-67-371	6700A -1	2 - M 9	0000-67-0958-17	6152AC-1	2 - J 8	0000-67-D21A-3A	6142AC-1	2 - G 8	0000-67-1977-07	6132AC-1	2 - C 8	0000-67-1983-78	6152AC-1	2 - J 8
1011-67-375	6730A -1	2 - G10	0000-67-0970-17	6142AB-1	2 - F 8	0000-67-D22A-3A	6142AC-1	2 - G 8	0000-67-1977-09	6132AC-1	2 - C 8	0000-67-1988-67	6152A -1	2 - H 8
0000-67-0402-83	6132A -1	2 - J 7	0000-67-0970-17	6142AC-1	2 - G 8	0000-67-D23A-3B	6142A -1	2 - E 8	0000-67-1977-99	6132AC-1	2 - C 8	0000-67-1988-67	6152AB-1	2 - I 8
0000-67-0402-83	6132AB-1	2 - L 7	0000-67-0977-05	6152AB-1	2 - I 8	0000-67-D23A-6A	6142AB-1	2 - F 8	0000-67-1977-34	6152A -1	2 - H 8	0000-67-1988-67	6152AC-1	2 - J 8
0000-67-0402-83	6132AC-1	2 - C 8	8342-67-985	6701A -1	2 - N 9	0000-67-D23A-6A	6142AC-1	2 - G 8	0000-67-1977-27	6152A -1	2 - H 8	0000-67-1992-98	6152A -1	2 - H 8
0000-67-0402-83	6152A -1	2 - H 8	0000-67-A20A-3A	6132AC-1	2 - C 8	0000-67-D24A-3A	6142AC-1	2 - G 8	0000-67-1977-05	6152A -1	2 - H 8	0000-67-1992-98	6152AB-1	2 - I 8
0000-67-0402-83	6152AB-1	2 - I 8	0000-67-A43A-6F	6132A -1	2 - J 7	0000-67-M00A-3A	6152A -1	2 - H 8	0000-67-1977-25	6152A -1	2 - H 8	0000-67-1992-98	6152AC-1	2 - J 8
0000-67-0402-83	6152AC-1	2 - J 8	0000-67-A43A-6F	6132AB-1	2 - L 7	0000-67-M00A-3A	6152A -1	2 - H 8	0000-67-1977-34	6152AB-1	2 - I 8	0000-67-1995-39	6152A -1	2 - H 8
0000-67-0411-12	6152A -1	2 - H 8	0000-67-A43A-6F	6132AC-1	2 - C 8	0000-67-M00A-3A	6152AB-1	2 - I 8	0000-67-1977-27	6152AB-1	2 - I 8	0000-67-1995-30	6152A -1	2 - H 8
0000-67-0411-12	6152AB-1	2 - I 8	0000-67-A44A-6F	6132A -1	2 - J 7	0000-67-M00A-3A	6152AB-1	2 - I 8	0000-67-1977-25	6152AB-1	2 - I 8	0000-67-1995-30	6152AB-1	2 - I 8
0000-67-0411-12	6152AC-1	2 - J 8	0000-67-A44A-6F	6132AB-1	2 - L 7	0000-67-M00A-3A	6152AC-1	2 - J 8	0000-67-1977-34	6152AC-1	2 - J 8	0000-67-1995-30	6152AC-1	2 - J 8
1480-67-421A	6750A -1	2 - I10	0000-67-A44A-6F	6132AC-1	2 - C 8	0000-67-X10A-06	6142AB-1	2 - F 8	0000-67-1977-25	6152AC-1	2 - J 8	0000-67-1995-93	6152AC-1	2 - J 8
1480-67-435	6750A -1	2 - I10	0000-67-A46A-3F	6132A -1	2 - J 7	0000-67-X10A-06	6142AC-1	2 - G 8	0000-67-1977-05	6152AC-1	2 - J 8	0000-67-1997-24	6132A -1	2 - J 7
1480-67-436	6750A -1	2 - I10	0000-67-A46A-3F	6132AB-1	2 - L 7	0000-67-X10M-25	6142AB-1	2 - F 8	0000-67-1978-35	6132A -1	2 - J 7	0000-67-1997-59	6132A -1	2 - J 7
0000-67-0440-49	6132A -1	2 - J 7	0000-67-A50A-3A	6132AC-1	2 - C 8	0000-67-X10M-13	6142AB-1	2 - F 8	0000-67-1978-35	6132AB-1	2 - L 7	0000-67-1997-27	6132A -1	2 - J 7
0000-67-0440-53	6132AB-1	2 - L 7	0000-67-A90A-3A	6132AC-1	2 - C 8	0000-67-X10M-25	6142AC-1	2 - G 8	0000-67-1978-37	6152A -1	2 - H 8	0000-67-1997-59	6132AB-1	2 - L 7
0000-67-0440-53	6132AC-1	2 - C 8	0000-67-A93A-3F	6132AC-1	2 - C 8	0000-67-X10M-13	6142AC-1	2 - G 8	0000-67-1978-37	6152AB-1	2 - I 8	0000-67-1997-27	6132AB-1	2 - L 7
1480-67-450C	6750A -1	2 - I10	0000-67-B30A-4A	6152AB-1	2 - I 8	0000-67-X30A-01	6132A -1	2 - J 7	0000-67-1978-37	6152AC-1	2 - J 8	0000-67-1997-24	6132AB-1	2 - L 7
1410-67-480C	6750A -1	2 - I10	0000-67-B30A-4A	6152AC-1	2 - J 8	0000-67-X30A-01	6132AB-1	2 - L 7	0000-67-1981-86	6132A -1	2 - J 7	0000-67-1997-86	6132AC-1	2 - C 8
2522-67-480B	6720A -1	2 - F10	0000-67-B32A-4A	6152AB-1	2 - I 8	0000-67-X30A-01	6132AC-1	2 - C 8	0000-67-1981-86	6132AB-1	2 - L 7	0000-67-1997-27	6132AC-1	2 - C 8
8871-67-500	6720A -1	2 - F10	0000-67-B32A-4A	6152AC-1	2 - J 8	0000-67-X40A-01	6142A -1	2 - E 8	0000-67-1981-86	6132AC-1	2 - C 8	0000-67-1997-24	6132AC-1	2 - C 8
1480-67-501A	6750A -1	2 - I10	0000-67-B44A-3B	6152A -1	2 - H 8	0000-67-X40A-01	6142AB-1	2 - F 8	0000					

PART NUMBER INDEX

PART NUMBER	SECTION	LOCATION	PART NUMBER	SECTION	LOCATION	PART NUMBER	SECTION	LOCATION	PART NUMBER	SECTION	LOCATION	PART NUMBER	SECTION	LOCATION
0000-67-1997-59	6152A -1	2 - H 8	FA04-68-070A70	6800A -1	2 - K10	FA42-68-390	6840A -1	2 - C11	FA02-68-520E	6840A -1	2 - C11	8871-68-710 70	6840A -2	2 - D11
0000-67-1998-13	6132A -1	2 - J 7	8973-68-090C	6900A -1	2 - I11	FA42-68-390 12	6840A -1	2 - C11	FA04-68-520D	6840A -1	2 - C11	FA01-68-710	6800A -1	2 - K10
0000-67-1998-16	6132A -1	2 - J 7	FA01-68-110A	6800A -1	2 - K10	FA42-68-390 72	6840A -1	2 - C11	FA04-68-520D10	6840A -1	2 - C11	FA01-68-710 00	6800A -1	2 - K10
0000-67-1998-14	6132A -1	2 - J 7	FA01-68-110A00	6800A -1	2 - K10	FA42-68-390 77	6840A -1	2 - C11	FA04-68-520D29	6840A -1	2 - C11	FA01-68-710 11	6800A -1	2 - K10
0000-67-1998-14	6132AB-1	2 - L 7	FA01-68-110A11	6800A -1	2 - K10	FA42-68-390 85	6840A -1	2 - C11	FA04-68-520D70	6840A -1	2 - C11	FA01-68-710 29	6800A -2	2 - L10
0000-67-1998-13	6132AB-1	2 - L 7	FA01-68-110A29	6800A -1	2 - K10	FA01-68-420A	5840A -1	2 - C 7	FA01-68-550D	6840A -1	2 - C11	FA01-68-710 70	6800A -2	2 - L10
0000-67-1998-13	6132AC-1	2 - C 8	FA01-68-110A70	6800A -1	2 - K10	FA01-68-420A10	5840A -1	2 - C 7	FA01-68-550D01	6840A -1	2 - C11	8871-68-720	6840A -2	2 - D11
0000-67-1998-14	6132AC-1	2 - C 8	FA01-68-120A	6800A -1	2 - K10	FA01-68-420D	5840A -1	2 - C 7	FA01-68-550D10	6840A -1	2 - C11	8871-68-720 00	6840A -2	2 - D11
0000-67-1998-49	6152A -1	2 - H 8	FA01-68-120A00	6800A -1	2 - K10	FA01-68-420D00	5840A -1	2 - C 7	FA01-68-550D70	6840A -1	2 - C11	8871-68-720 10	6840A -2	2 - D11
0000-67-1998-51	6152A -1	2 - H 8	FA01-68-120A11	6800A -1	2 - K10	FA01-68-420D10	5840A -1	2 - C 7	FA02-68-550E	6840A -1	2 - C11	8871-68-720 29	6840A -2	2 - D11
0000-67-1998-83	6152A -1	2 - H 8	FA01-68-120A29	6800A -1	2 - K10	FA01-68-420D70	5840A -1	2 - C 7	FA02-68-550E00	6840A -1	2 - C11	8871-68-720 70	6840A -2	2 - D11
0000-67-1998-49	6152AB-1	2 - I 8	FA01-68-120A70	6800A -1	2 - K10	FA02-68-420D	5840A -1	2 - C 7	FA02-68-550E10	6840A -1	2 - C11	8871-68-770	6840A -2	2 - D11
0000-67-1998-83	6152AB-1	2 - I 8	FA01-68-172	6800A -2	2 - L10	FA02-68-420D00	5840A -1	2 - C 7	FA02-68-550E70	6840A -1	2 - C11	8871-68-770 00	6840A -2	2 - D11
0000-67-1998-49	6152AC-1	2 - J 8	G001-68-172	6800A -2	2 - L10	FA02-68-420D10	5840A -1	2 - C 7	FA04-68-550D	6840A -1	2 - C11	8871-68-770 11	6840A -2	2 - D11
0000-67-1998-83	6152AC-1	2 - J 8	8871-68-175	6800A -2	2 - L10	FA02-68-420D70	5840A -1	2 - C 7	FA04-68-550D10	6840A -2	2 - D11	8871-68-770 29	6840A -2	2 - D11
0000-67-2382-79	6152A -1	2 - H 8	FA01-68-190	6800A -2	2 - L10	FA03-68-420A	5840A -1	2 - C 7	FA04-68-550D70	6840A -2	2 - D11	8871-68-770 70	6840A -2	2 - D11
0000-67-2382-94	6152AB-1	2 - I 8	FA01-68-190 00	6800A -2	2 - L10	FA03-68-420A10	5840A -1	2 - C 7	FA01-68-620B	6860A -1	2 - F11	8871-68-790	6840A -2	2 - D11
0000-67-2382-94	6152AC-1	2 - J 8	FA01-68-190 11	6800A -2	2 - L10	FA03-68-420D	5840A -1	2 - C 7	FA01-68-651A	6860A -1	2 - F11	8871-68-790 00	6840A -2	2 - D11
0000-67-5234-03	6142A -1	2 - E 8	FA01-68-190 29	6800A -2	2 - L10	FA03-68-420D00	5840A -1	2 - C 7	1480-68-654A	6860A -1	2 - F11	8871-68-790 11	6840A -2	2 - D11
0000-67-5234-04	6142A -1	2 - E 8	FA01-68-190 70	6800A -2	2 - L10	FA03-68-420D10	5840A -1	2 - C 7	FA01-68-658	6860A -1	2 - F11	8871-68-790 29	6840A -2	2 - D11
0000-67-5234-01	6142A -1	2 - E 8	8871-68-221A	6800A -2	2 - L10	FA03-68-420D70	5840A -1	2 - C 7	8871-68-664B	6860A -1	2 - F11	8871-68-790 70	6840A -2	2 - D11
0000-67-5409-02	6142AB-1	2 - F 8	8871-68-221A00	6800A -2	2 - L10	FA04-68-420A	5840A -1	2 - C 7	FA01-68-666	6860A -1	2 - F11	0305-68-810A	3700A -2	1 - G 9
0000-67-5409-03	6142AB-1	2 - F 8	8871-68-221A11	6800A -2	2 - L10	FA04-68-420A10	5840A -1	2 - C 7	8871-68-667A	6860A -1	2 - F11	8871-68-851	6840A -2	2 - D11
0000-67-5409-03	6142AC-1	2 - G 8	8871-68-221A29	6800A -2	2 - L10	FA04-68-420A70	5840A -1	2 - C 7	FA01-68-671B	6860A -1	2 - F11	8871-68-851 00	6840A -2	2 - D11
0000-67-5409-02	6142AC-1	2 - G 8	8871-68-221A70	6800A -2	2 - L10	FA05-68-420C	5840A -1	2 - C 7	FA01-68-671B00	6860A -1	2 - F11	8871-68-851 11	6840A -2	2 - D11
0000-67-6716-56	6132AC-1	2 - C 8	8871-68-241A	6800A -2	2 - L10	FA05-68-420C10	5840A -1	2 - C 7	FA01-68-671B11	6860A -1	2 - F11	8871-68-851 70	6840A -2	2 - D11
0000-67-6716-50	6132AB-2	2 - M 7	8871-68-241A00	6800A -2	2 - L10	FA05-68-420C29	5840A -1	2 - C 7	FA01-68-671B70	6860A -1	2 - F11	8871-68-851 71	6840A -2	2 - D11
0000-67-6716-50	6132AC-2	2 - D 8	8871-68-241A11	6800A -2	2 - L10	FA05-68-420C70	5840A -1	2 - C 7	FA01-68-677	6860A -1	2 - F11	8871-68-855	6840A -3	2 - E11
0000-67-6716-17	6142AB-1	2 - F 8	8871-68-241A29	6800A -2	2 - L10	FA42-68-420A	5840A -1	2 - C 7	FA01-68-677 00	6860A -1	2 - F11	8871-68-861A	6840A -2	2 - D11
0000-67-6716-17	6142AC-1	2 - G 8	8871-68-241A70	6800A -2	2 - L10	FA42-68-420A01	5840A -1	2 - C 7	FA01-68-677 11	6860A -1	2 - F11	8871-68-861A00	6840A -2	2 - D11
FA01-68-021	6800A -1	2 - K10	8871-68-271A	6800A -2	2 - L10	FA42-68-420A11	5840A -1	2 - C 7	FA01-68-677 70	6860A -1	2 - F11	8871-68-861A11	6840A -2	2 - D11
FA01-68-021 01	6800A -1	2 - K10	8871-68-271A00	6800A -2	2 - L10	FA42-68-420A71	5840A -1	2 - C 7	FA02-68-677	6860A -1	2 - F11	8871-68-861A29	6840A -2	2 - D11
FA01-68-021 10	6800A -1	2 - K10	8871-68-271A11	6800A -2	2 - L10	FA01-68-450D	5840A -1	2 - C 7	FA02-68-677 00	6860A -1	2 - F11	8871-68-861A70	6840A -2	2 - D11
FA01-68-021 29	6800A -1	2 - K10	8871-68-271A29	6800A -2	2 - L10	FA01-68-450D00	5840A -1	2 - C 7	FA02-68-677 11	6860A -1	2 - F11	B006-68-865	6800A -3	2 - M10
FA01-68-021 70	6800A -1	2 - K10	8871-68-271A70	6800A -2	2 - L10	FA01-68-450D10	5840A -1	2 - C 7	FA02-68-677 70	6860A -1	2 - F11	8871-68-871A	6840A -2	2 - D11
FA01-68-021 71	6800A -1	2 - K10	8871-68-291A	6800A -2	2 - L10	FA01-68-450D70	5840A -1	2 - C 7	FA02-68-677A	6860A -1	2 - F11	8871-68-871A00	6840A -2	2 - D11
FA01-68-029A	6800A -3	2 - M10	8871-68-291A00	6800A -2	2 - L10	FA02-68-450D	5840A -2	2 - D 7	FA02-68-677A00	6860A -1	2 - F11	8871-68-871A11	6840A -2	2 - D11
FA01-68-030C	6800A -1	2 - K10	8871-68-291A11	6800A -2	2 - L10	FA02-68-450D00	5840A -2	2 - D 7	FA02-68-677A11	6860A -1	2 - F11	8871-68-871A29	6840A -2	2 - D11
FA01-68-030C02	6800A -1	2 - K10	8871-68-291A29	6800A -2	2 - L10	FA02-68-450D10	5840A -2	2 - D 7	FA02-68-677A70	6860A -1	2 - F11	8871-68-871A70	6840A -2	2 - D11
FA01-68-030C10	6800A -1	2 - K10	8871-68-291A70	6800A -3	2 - M10	FA02-68-450D70	5840A -2	2 - D 7	FA02-68-677A72	6860A -1	2 - F11	1480-68-890C	6840A -2	2 - D11
FA01-68-030C70	6800A -1	2 - K10	FA03-68-370	6840A -1	2 - C11	FA03-68-450D	5840A -2	2 - D 7	FA03-68-677	6860A -1	2 - F11	1480-68-890C00	6840A -2	2 - D11
FA04-68-030C	6800A -1	2 - K10	FA03-68-370 12	6840A -1	2 - C11	FA03-68-450D00	5840A -2	2 - D 7	FA03-68-677 00	6860A -1	2 - F11	1480-68-890C11	6840A -3	2 - E11
B001-68-032	5310A -1	2 - G 4	FA03-68-370 72	6840A -1	2 - C11	FA03-68-450D10	5840A -2	2 - D 7	FA03-68-677 11	6860A -1	2 - F11	1480-68-890C29	6840A -3	2 - E11
B001-68-032 00	5310A -1	2 - G 4	FA03-68-370 77	6840A -1	2 - C11	FA03-68-450D70	5840A -2	2 - D 7	FA03-68-677 70	6860A -1	2 - F11	1480-68-890C70	6840A -3	2 - E11
B001-68-032 08	5310A -1	2 - G 4	FA03-68-370 85	6840A -1	2 - C11	FA05-68-450C	5840A -2	2 - D 7	FA03-68-677 72	6860A -1	2 - F11	8341-68-890C	6840A -3	2 - E11
FA24-68-032	6900A -1	2 - I11	FA42-68-370	6840A -1	2 - C11	FA05-68-450C10	5840A -2	2 - D 7	FA01-68-695C	6860A -1	2 - F11	8341-68-890C00	6840A -3	2 - E11
FA24-68-032 00	6900A -1	2 - I11	FA42-68-370 12	6840A -1	2 - C11	FA05-68-450C70	5840A -2	2 - D 7	FA01-68-695C11	6860A -1	2 - F11	8341-68-890C11	6840A -3	2 - E11
FA24-68-032 11	6900A -1	2 - I11	FA42-68-370 72	6840A -1	2 - C11	FA42-68-450A	5840A -2	2 - D 7	FA01-68-695C77	6860A -1	2 - F11	8341-68-890C29	6840A -3	2 - E11
FA24-68-032 70	6900A -1	2 - I11	FA42-68-370 77	6840A -1	2 - C11	FA42-68-450A01	5840A -2	2 - D 7	FA01-68-695C85	6860A -1	2 - F11	8341-68-890C70	6840A -3	2 - E11
FA24-68-032 71	6900A -1	2 - I11	FA42-68-370 85	6840A -1	2 - C11	FA42-68-450A11	5840A -2	2 - D 7	8871-68-696B	6860A -1	2 - F11	FA02-68-911	5800A -1	2 - J 6
0810-68-070E	6870A -1	2 - H11	FA03-68-390	6840A -1	2 - C11	FA42-68-450A71	5840A -2	2 - D 7	8871-68-696B65	6860A -1	2 - F11	FA02-68-911 01	5800A -1	2 - J 6
FA04-68-070A	6800A -1	2 - K10	FA03-68-390 12	6840A -1	2 - C11	FA01-68-520D	6840A -1	2 - C11	8871-68-710	6840A -2	2 - D11	FA02-68-911 12	5800A -1	2 - J 6
FA04-68-070A02	6800A -1	2 - K10	FA03-68-390 72	6840A -1	2 - C11	FA01-68-520D01	6840A -1	2 - C11	8871-68-710 00	6840A -2	2 - D11	FA02-68-911 29	5800A -1	2 - J 6
FA04-68-070A10	6800A -1	2 - K10	FA03-68-390 77	6840A -1	2 - C11	FA01-68-520D10	6840A -1	2 - C11	8871-68-710 10	6840A -2	2 - D11	FA02-68-911 34	5800A -1	2 - J 6
FA04-68-070A28	6800A -1	2 - K10	FA03-68-390 85	6840A -1	2 - C11	FA01-68-520D70	6840A -1	2 - C11	8871-68-710 29	6840A -2	2 - D11	0305-68-951	5180A -1	2 - E 4

PART NUMBER INDEX

PART NUMBER INDEX

PART NUMBER	SECTION	LOCATION	PART NUMBER	SECTION	LOCATION	PART NUMBER	SECTION	LOCATION	PART NUMBER	SECTION	LOCATION	PART NUMBER	SECTION	LOCATION
FA01-68-960C	6800A -1	2 - K10	8341-69-178	6900A -1	2 - J11	8341-69-580 20	6900A -3	2 - K11	FA01-71-400B	5340A -1	2 - I4	FA42-76-429	6110A -1	2 - G7
FA01-68-960C00	6800A -1	2 - K10	8871-69-178	6900A -1	2 - J11	8341-69-580 29	6900A -3	2 - K11	FA42-71-400B	5340A -1	2 - I4	8871-76-430A	6110A -1	2 - G7
FA01-68-960C11	6800A -1	2 - K10	8341-69-182	6900A -1	2 - J11	3781-69-650	6870A -1	2 - H11	8544-72-502	5800A -1	2 - J6	8871-76-432	6110A -1	2 - G7
FA01-68-960C29	6800A -1	2 - K10	8341-69-191	6900A -2	2 - J11	8173-69-670	6870A -1	2 - H11	8871-72-761	4200A -1	1 - M9	8871-76-433	6110A -1	2 - G7
FA01-68-960C70	6800A -1	2 - K10	FA01-69-220A	6900A -2	2 - J11	FA01-69-760	6900A -3	2 - K11	0305-72-852A	5830A -2	2 - L6	8871-76-434	6110A -1	2 - G7
FA56-68-965	6800A -3	2 - M10	FA03-69-220A	6900A -2	2 - J11	FA01-69-760 00	6900A -3	2 - K11	1482-74-030	5340A -1	2 - I4	8871-76-450	6120A -1	2 - I7
FA01-68-970B	6800A -1	2 - K10	FA01-69-232	6900A -2	2 - J11	FA01-69-760 11	6900A -3	2 - K11	8871-74-030	5340A -1	2 - I4	8871-76-451	6120A -1	2 - I7
FA01-68-970B00	6800A -1	2 - K10	8341-69-270	6900A -2	2 - J11	FA01-69-760 29	6900A -3	2 - K11	FA01-74-040A	5310A -2	2 - H4	8671-76-452	6120A -1	2 - I7
FA01-68-970B11	6800A -1	2 - K10	8341-69-270 02	6900A -2	2 - J11	FA01-69-760 70	6900A -3	2 - K11	8871-74-250	5230A -1	2 - F4	8871-76-453A	6120A -1	2 - I7
FA01-68-970B29	6800A -1	2 - K10	8341-69-270 10	6900A -2	2 - J11	FA42-69-760A	6900A -3	2 - K11	1907-75-102A	5540A -1	2 - N4	8871-76-454	6120A -1	2 - I7
FA01-68-970B70	6800A -1	2 - K10	8341-69-270 28	6900A -2	2 - J11	FA42-69-760A00	6900A -3	2 - K11	1482-75-890D	6300A -1	2 - L8	8871-76-455	6120A -1	2 - I7
FA01-68-981	6800A -2	2 - L10	8341-69-270 70	6900A -2	2 - J11	FA42-69-760A11	6900A -3	2 - K11	8341-75-890D	6300A -1	2 - L8	8871-76-456	6120A -1	2 - I7
FA01-68-981 00	6800A -2	2 - L10	8341-69-320	6900A -2	2 - J11	FA42-69-760A29	6900A -3	2 - K11	8208-75-901	0900A -1	2 - C3	8871-76-457	6120A -1	2 - I7
FA01-68-981 11	6800A -2	2 - L10	8341-69-320 02	6900A -2	2 - J11	FA42-69-760A70	6900A -3	2 - K11	8208-75-901	0900A -1	2 - C3	8871-76-458	6120A -1	2 - I7
FA01-68-981 29	6800A -2	2 - L10	8341-69-320 10	6900A -2	2 - J11	FA42-69-762	6900A -3	2 - K11	0315-76-028	6115A -1	2 - H7	8871-76-459	6120A -1	2 - I7
FA01-68-981 70	6800A -2	2 - L10	8341-69-320 28	6900A -2	2 - J11	0866-69-885A	5370A -1	2 - K4	0208-76-071	6560A -2	2 - G11	8871-76-460	6120A -1	2 - I7
FA01-68-991	6800A -2	2 - L10	8341-69-320 70	6900A -2	2 - J11	0866-69-885A	6860A -2	2 - G11	HA40-76-201	0900A -1	2 - C3	8871-76-461	6120A -1	2 - I7
FA01-68-991 00	6800A -2	2 - L10	FA04-69-320	6900A -2	2 - J11	0866-69-885A00	5370A -1	2 - K4	FA01-76-210	0900A -1	2 - C3	8871-76-462	6120A -1	2 - I7
FA01-68-991 11	6800A -2	2 - L10	FA04-69-320 02	6900A -2	2 - J11	0866-69-885A00	6860A -2	2 - G11	FA43-76-210	0900A -1	2 - C3	8871-76-463	6120A -1	2 - I7
FA01-68-991 29	6800A -2	2 - L10	FA04-69-320 10	6900A -2	2 - J11	0376-69-941	6900A -3	2 - K11	FA01-76-220	0900A -1	2 - C3	8871-76-464	6120A -1	2 - I7
FA01-68-991 70	6800A -2	2 - L10	FA04-69-320 28	6900A -2	2 - J11	0376-69-941 01	6900A -3	2 - K11	FA43-76-220	0900A -1	2 - C3	8871-76-465	6120A -1	2 - I7
0000-68-110-00	1580A -1	1 - N4	FA04-69-320 70	6900A -2	2 - J11	0376-69-941B	6900A -3	2 - K11	FA43-76-230	0900A -1	2 - C3	8871-76-466	6110A -1	2 - G7
8595-69-011B	6930A -1	2 - L11	FA01-69-371A	5840A -2	2 - D7	0376-69-941B01	6900A -3	2 - K11	FA01-76-250	0900A -1	2 - C3	8871-76-466	6120A -1	2 - I7
FA42-69-013	6930A -1	2 - L11	FA01-69-371A00	5840A -2	2 - D7	8871-70-020E	5340A -1	2 - I4	FA43-76-250	0900A -1	2 - C3	8871-76-467A	6120A -1	2 - I7
8871-69-014C	6930A -1	2 - L11	FA01-69-371A10	5840A -2	2 - D7	8871-70-051D	5340A -1	2 - I4	FA01-76-260	0900A -1	2 - C3	8871-76-468	6120A -1	2 - I7
FA42-69-014B	6930A -1	2 - L11	FA01-69-371A29	5840A -2	2 - D7	FA01-70-100I	5340A -1	2 - I4	BE32-76-290A	0900A -1	2 - C3	8871-76-469	6120A -1	2 - I7
8374-69-034A	6930A -1	2 - L11	FA01-69-371A80	5840A -2	2 - D7	FA54-70-210A	5340A -1	2 - I4	GA02-76-290	0900A -1	2 - C3	8871-76-470	6110A -1	2 - G7
N201-69-036	6930A -1	2 - L11	FA01-69-372	5840A -2	2 - D7	8871-70-220C	5340A -1	2 - I4	FA42-76-400A	6110A -1	2 - G7	8871-76-470	6120A -1	2 - I7
N203-69-036	6930A -1	2 - L11	FA01-69-372 00	5840A -2	2 - D7	8871-70-240C	5340A -1	2 - I4	FA42-76-401	6110A -1	2 - G7	8871-76-471	6110A -1	2 - G7
N221-69-036	6930A -1	2 - L11	FA01-69-372 10	5840A -2	2 - D7	8871-70-251	5340A -1	2 - I4	8871-76-402	6110A -1	2 - G7	8871-76-471	6120A -1	2 - I7
N223-69-036	6930A -1	2 - L11	FA01-69-372 29	5840A -2	2 - D7	8871-70-260	5310A -1	2 - G4	FA42-76-403	6110A -1	2 - G7	0866-76-474	6120A -1	2 - I7
N231-69-036	6930A -1	2 - L11	FA01-69-372 80	5840A -2	2 - D7	8871-70-271B	5340A -1	2 - I4	8871-76-404	6110A -1	2 - G7	0866-76-475	6120A -1	2 - I7
N233-69-036	6930A -1	2 - L11	FA01-69-374	5840A -2	2 - D7	8871-70-311A	5340A -1	2 - I4	8871-76-405	6110A -1	2 - G7	0866-76-476	6120A -1	2 - I7
N201-69-044A	6930A -1	2 - L11	FA01-69-374 00	5840A -2	2 - D7	0305-70-335	6800A -3	2 - M10	8871-76-406	6110A -1	2 - G7	8871-76-478	6120A -1	2 - I7
N221-69-044	6930A -1	2 - L11	FA01-69-374 10	5840A -3	2 - E7	FA01-70-400A	5340A -1	2 - I4	8871-76-407	6110A -1	2 - G7	8871-76-479	6120A -1	2 - I7
N231-69-044A	6930A -1	2 - L11	FA01-69-374 29	5840A -3	2 - E7	0839-70-449	6300A -1	2 - L8	8871-76-408	6110A -1	2 - G7	F001-76-500A	6115A -1	2 - H7
0187-69-049A	5170A -1	2 - D4	FA01-69-374 80	5840A -3	2 - E7	0187-70-491	4200A -1	1 - M9	8871-76-409	6110A -1	2 - G7	8249-76-501	6115A -1	2 - H7
0187-69-049A	6300A -1	2 - L8	FA01-69-391A	5840A -2	2 - D7	0256-70-526A	6300A -1	2 - L8	8871-76-410A	6110A -1	2 - G7	FA01-76-502	6115A -1	2 - H7
FA01-69-065	6930A -1	2 - L11	FA01-69-391A00	5840A -2	2 - D7	8871-70-640A	5340A -1	2 - I4	8871-76-411A	6110A -1	2 - G7	8871-76-503A	6115A -1	2 - H7
FA01-69-065 00	6930A -1	2 - L11	FA01-69-391A10	5840A -2	2 - D7	8973-70-640A	5340A -1	2 - I4	8871-76-412A	6110A -1	2 - G7	8563-76-504	6115A -1	2 - H7
FA01-69-065 01	6930A -1	2 - L11	FA01-69-391A29	5840A -2	2 - D7	FA01-70-700A	5340A -1	2 - I4	8871-76-413	6110A -1	2 - G7	8871-76-505	6115A -1	2 - H7
FA02-69-073A	6930A -1	2 - L11	FA01-69-391A80	5840A -2	2 - D7	FA04-70-700A	5340A -1	2 - I4	8871-76-414	6110A -1	2 - G7	8341-76-506	6115A -1	2 - H7
8341-69-110A	6900A -1	2 - J11	FA01-69-392	5840A -2	2 - D7	FA01-70-750C	5340A -1	2 - I4	8531-76-415	6115A -1	2 - H7	8871-76-507	6115A -1	2 - H7
8871-69-110B	6900A -1	2 - J11	FA01-69-392 00	5840A -2	2 - D7	FA01-70-791	5340A -1	2 - I4	8871-76-415	6110A -1	2 - G7	8562-76-508	6115A -1	2 - H7
8341-69-115	6900A -2	2 - J11	FA01-69-392 10	5840A -2	2 - D7	FA16-71-020C	5340A -1	2 - I4	8871-76-416	6110A -1	2 - G7	8871-76-508	6115A -1	2 - H7
8341-69-116	6900A -2	2 - J11	FA01-69-392 29	5840A -2	2 - D7	8871-71-051D	5340A -1	2 - I4	8871-76-417	6110A -1	2 - G7	8871-76-509	6115A -1	2 - H7
8871-69-117A	6900A -1	2 - J11	FA01-69-392 80	5840A -2	2 - D7	FA01-71-100I	5340A -1	2 - I4	8871-76-418	6110A -1	2 - G7	8871-76-510	6115A -1	2 - H7
8218-69-118	6900A -1	2 - J11	8341-69-570	6900A -2	2 - J11	0259-71-158	6115A -1	2 - H7	8871-76-419	6110A -1	2 - G7	8871-76-511	6115A -1	2 - H7
8341-69-122	6900A -1	2 - J11	8341-69-570 00	6900A -2	2 - J11	FA54-71-210B	5340A -1	2 - I4	8871-76-420	6110A -1	2 - G7	8871-76-512	6115A -1	2 - H7
8341-69-123	6900A -1	2 - J11	8341-69-570 10	6900A -2	2 - J11	8871-71-220C	5340A -1	2 - I4	8871-76-421	6110A -1	2 - G7	8871-76-513	6115A -1	2 - H7
8341-69-131	6900A -1	2 - J11	8341-69-570 20	6900A -2	2 - J11	8871-71-240C	5340A -1	2 - I4	8871-76-422	6110A -1	2 - G7	8871-76-514	6115A -1	2 - H7
8341-69-170A	6900A -1	2 - J11	8341-69-570 29	6900A -3	2 - K11	8871-71-251	5340A -1	2 - I4	8871-76-425	6110A -1	2 - G7	8871-76-515	6115A -1	2 - H7
8871-69-170B	6900A -2	2 - J11	8341-69-580	6900A -3	2 - K11	8871-71-260	5310A -2	2 - H4	3794-76-426	6120A -1	2 - I7	8871-76-516	6115A -1	2 - H7
8871-69-177	6900A -2	2 - J11	8341-69-580 00	6900A -3	2 - K11	8871-71-271B	5340A -1	2 - I4	8871-76-427	6110A -1	2 - G7	8871-76-517	6115A -1	2 - H7
8871-69-177A	6900A -2	2 - J11	8341-69-580 10	6900A -3	2 - K11	8871-71-311A	5340A -1	2 - I4	8871-76-428	6110A -1	2 - G7	8871-76-518	6115A -1	2 - H7

PART NUMBER INDEX

PART NUMBER	SECTION	LOCATION	PART NUMBER	SECTION	LOCATION	PART NUMBER	SECTION	LOCATION	PART NUMBER	SECTION	LOCATION	PART NUMBER	SECTION	LOCATION
8595-76-552	6100A -1	2 - F 7	0000-81-0287-83	6680A -2	2 - K 9	FA07-88-110 00	5700A -1	2 - H 5	F007-88-120	5700A -2	2 - I 5	FA09-88-131 10	5700A -3	2 - J 5
8871-76-601B	6730A -1	2 - G10	0000-81-0287-83	6680A -2	2 - K 9	FA07-88-110 10	5700A -1	2 - H 5	F007-88-120 00	5700A -2	2 - I 5	FA09-88-131 70	5700A -3	2 - J 5
8871-76-602B	6730A -1	2 - G10	0000-81-0287-83	6680A -2	2 - K 9	FA07-88-110 70	5700A -1	2 - H 5	F007-88-120 10	5700A -2	2 - I 5	FA09-88-131A	5700AA-3	2 - E 6
8871-76-603A	6730A -1	2 - G10	0000-81-0287	6680A -2	2 - K 9	FA07-88-110A	5700AA-2	2 - D 6	F007-88-120 70	5700A -2	2 - I 5	FA09-88-131A01	5700AA-3	2 - E 6
8871-76-604A	6730A -1	2 - G10	0000-81-0423	6680A -1	2 - J 9	FA07-88-110A01	5700AA-2	2 - D 6	FA02-88-120	5700A -2	2 - I 5	FA09-88-131A11	5700AA-3	2 - E 6
8871-76-605A	6730A -1	2 - G10	0000-81-456C	6680A -1	2 - J 9	FA07-88-110A11	5700AA-2	2 - D 6	FA09-88-120	5700AA-3	2 - E 6	FA09-88-131A71	5700AA-3	2 - E 6
1480-76-607	6750A -1	2 - I10	0000-81-481C	6680A -1	2 - J 9	FA07-88-110A71	5700AA-2	2 - D 6	FA07-88-130	5700A -2	2 - I 5	8871-88-140	5700A -3	2 - J 5
1175-76-609	6730A -1	2 - G10	0000-81-0643	6680A -2	2 - K 9	FA08-88-110	5700A -1	2 - H 5	FA07-88-130 00	5700A -2	2 - I 5	FA02-88-140	5700A -3	2 - J 5
1480-76-610	6760A -1	2 - J10	0000-81-0790	6680A -1	2 - J 9	FA08-88-110 00	5700A -1	2 - H 5	FA07-88-130 10	5700A -2	2 - I 5	FA09-88-140	5700AA-4	2 - F 6
8872-76-610	6740A -1	2 - H10	0000-81-0790	6680A -1	2 - J 9	FA08-88-110 70	5700A -1	2 - H 5	FA07-88-130 70	5700A -2	2 - I 5	3532-88-151	5700A -3	2 - J 5
1480-76-612	6760A -1	2 - J10	0000-81-880C	6680A -1	2 - J 9	FA08-88-110A	5700AA-2	2 - D 6	FA07-88-130A	5700AA-3	2 - E 6	FA09-88-151	5700A -3	2 - J 5
8872-76-612	6740A -1	2 - H10	0000-81-0975-83	6680A -1	2 - J 9	FA08-88-110A01	5700AA-2	2 - D 6	FA07-88-130A01	5700AA-3	2 - E 6	FA09-88-151	5700AA-4	2 - F 6
8236-76-614	6740A -1	2 - H10	0000-81-3001	6680A -1	2 - J 9	FA08-88-110A71	5700AA-2	2 - D 6	FA07-88-130A11	5700AA-3	2 - E 6	F005-88-152	5700A -3	2 - J 5
8532-76-614	6760A -1	2 - J10	0000-81-5210-01	6680A -2	2 - K 9	FA09-88-110	5700A -1	2 - H 5	FA07-88-130A71	5700AA-3	2 - E 6	F005-88-152	5700AA-4	2 - F 6
8532-76-617	6760A -1	2 - J10	0000-81-5216-0'	6680A -2	2 - K 9	FA09-88-110 00	5700A -1	2 - H 5	FA08-88-130	5700A -2	2 - I 5	FA07-88-153	5700A -3	2 - J 5
8236-76-618	6740A -1	2 - H10	0000-81-7910-83	6680A -1	2 - J 9	FA09-88-110 10	5700A -1	2 - H 5	FA08-88-130 00	5700A -2	2 - I 5	FA07-88-160	5700A -3	2 - J 5
8532-76-618	6760A -1	2 - J10	0000-81-7910-83	6680A -2	2 - K 9	FA09-88-110 70	5700A -1	2 - H 5	FA08-88-130 70	5700A -2	2 - I 5	FA07-88-160 00	5700A -3	2 - J 5
1410-76-619	6760A -1	2 - J10	0000-81-9700-83	6680A -1	2 - J 9	FA09-88-110A	5700AA-2	2 - D 6	FA08-88-130A	5700AA-3	2 - E 6	FA07-88-160 10	5700A -3	2 - J 5
8236-76-619A	6740A -1	2 - H10	0000-81-9710-83	6680A -1	2 - J 9	FA09-88-110A01	5700AA-2	2 - D 6	FA08-88-130A01	5700AA-3	2 - E 6	FA07-88-160 70	5700A -3	2 - J 5
1029-76-621	6750A -1	2 - I10	F001-86-260	3700A -1	1 - F 9	FA09-88-110A11	5700AA-2	2 - D 6	FA08-88-130A71	5700AA-3	2 - E 6			
1480-76-623	6750A -1	2 - I10	0702-87-132	6750A -1	2 - I10	FA09-88-110A71	5700AA-2	2 - D 6	FA09-88-130	5700A -2	2 - I 5	FA07-88-160A	5700AA-4	2 - F 6
1480-76-624A	6750A -1	2 - I10	0259-87-134	6750A -1	2 - I10	FA07-88-111	5700A -1	2 - H 5	FA09-88-130 00	5700A -2	2 - I 5	FA07-88-160A01	5700AA-4	2 - F 6
1480-76-626	6750A -1	2 - I10	0727-87-844	6730A -1	2 - G10	FA07-88-111 00	5700A -1	2 - H 5	FA09-88-130 10	5700A -2	2 - I 5	FA07-88-160A11	5700AA-4	2 - F 6
8144-76-631	6750A -1	2 - I10	0824-87-846	6730A -1	2 - G10	FA07-88-111 10	5700A -1	2 - H 5	FA09-88-130 70	5700A -2	2 - I 5	FA07-88-160A71	5700AA-4	2 - F 6
8562-76-631A	6730A -1	2 - G10	0305-87-956	6730A -1	2 - G10	FA07-88-111 70	5700A -1	2 - H 5	FA09-88-130A	5700AA-3	2 - E 6	FA08-88-160	5700A -3	2 - J 5
F023-76-631	6730A -1	2 - G10	FA08-88-014	5700AA-2	2 - D 6	FA07-88-111A	5700AA-2	2 - D 6	FA09-88-130A01	5700AA-3	2 - E 6	FA08-88-160 00	5700A -3	2 - J 5
8134-76-641	6750A -1	2 - I10	FA08-88-014 01	5700AA-2	2 - D 6	FA07-88-111A01	5700AA-2	2 - D 6	FA09-88-130A11	5700AA-3	2 - E 6	FA08-88-160 70	5700A -3	2 - J 5
8871-76-641	6730A -1	2 - G10	FA08-88-014 71	5700AA-2	2 - D 6	FA07-88-111A11	5700AA-2	2 - D 6	FA09-88-130A71	5700AA-3	2 - E 6	FA08-88-160A	5700AA-4	2 - F 6
8871-76-655A	6730A -1	2 - G10	8183-88-101	5700A -1	2 - H 5	FA07-88-111A71	5700AA-2	2 - D 6	FA10-88-130A	5700AA-3	2 - E 6	FA08-88-160A01	5700AA-4	2 - F 6
8871-76-656A	6730A -1	2 - G10	8183-88-101	5700AA-1	2 - C 6	FA08-88-111	5700A -1	2 - H 5	FA10-88-130A01	5700AA-3	2 - E 6	FA08-88-160A71	5700AA-4	2 - F 6
8871-76-657	6730A -1	2 - G10	8531-88-101	5700A -1	2 - H 5	FA08-88-111 00	5700A -1	2 - H 5	FA10-88-130A11	5700AA-3	2 - E 6	FA09-88-160	5700A -3	2 - J 5
1410-76-671	6750A -1	2 - I10	8183-88-102	5700A -1	2 - H 5	FA08-88-111 70	5700A -1	2 - H 5	FA10-88-130A71	5700AA-3	2 - E 6	FA09-88-160 00	5700A -3	2 - J 5
2522-76-671A	6720A -1	2 - F10	8183-88-102	5700AA-1	2 - C 6	FA08-88-111A	5700AA-2	2 - D 6	FA07-88-131	5700A -2	2 - I 5	FA09-88-160 10	5700A -3	2 - J 5
1410-76-672A	6750A -1	2 - I10	F005-88-103	5700A -1	2 - H 5	FA08-88-111A01	5700AA-2	2 - D 6	FA07-88-131 00	5700A -4	2 - K 5	FA09-88-160 70	5700A -3	2 - J 5
8532-76-672	6720A -1	2 - F10	F005-88-103	5700AA-1	2 - C 6	FA08-88-111A71	5700AA-2	2 - D 6	FA07-88-131 00	5700A -2	2 - I 5	FA09-88-160A	5700AA-4	2 - F 6
8173-76-675	6720A -1	2 - F10	FA07-88-104	5700AA-1	2 - C 6	FA09-88-111	5700A -1	2 - H 5	FA07-88-131 00	5700A -4	2 - K 5	FA09-88-160A01	5700AA-4	2 - F 6
BA02-76-673	6720A -1	2 - F10	FA07-88-104	5700AA-2	2 - D 6	FA09-88-111 00	5700A -1	2 - H 5	FA07-88-131 10	5700A -4	2 - K 5	FA09-88-160A11	5700AA-4	2 - F 6
8527-77-739	1040A -2	1 - F 3	FA07-88-104 01	5700AA-2	2 - D 6	FA09-88-111 10	5700A -2	2 - I 5	FA07-88-131 10	5700A -2	2 - I 5	FA09-88-160A71	5700AA-4	2 - F 6
0000-78-559	3700A -1	1 - F 9	FA07-88-104 11	5700AA-2	2 - D 6	FA09-88-111 70	5700A -2	2 - I 5	FA07-88-131 70	5700A -2	2 - I 5	FA07-88-161	5700A -3	2 - J 5
0000-78-648	3700A -1	1 - F 9	FA07-88-104 71	5700AA-2	2 - D 6	FA09-88-111A	5700AA-2	2 - D 6	FA07-88-131 70	5700A -4	2 - K 5	FA07-88-161 00	5700A -3	2 - J 5
0000-78-6485	3700A -1	1 - F 9	FA09-88-104	5700A -1	2 - H 5	FA09-88-111A01	5700AA-2	2 - D 6	FA07-88-131A	5700AA-3	2 - E 6	FA07-88-161 10	5700A -3	2 - J 5
0000-80-124K	1850A -1	1 - M 5	FA09-88-104 00	5700A -1	2 - H 5	FA09-88-111A11	5700AA-3	2 - E 6	FA07-88-131A01	5700AA-3	2 - E 6	FA07-88-161 70	5700A -3	2 - J 5
9935-80-6999	1320A -1	1 - K 3	FA09-88-104 10	5700A -1	2 - H 5	FA09-88-111A71	5700AA-3	2 - E 6	FA07-88-131A11	5700AA-3	2 - E 6	FA07-88-161A	5700AA-4	2 - F 6
9935-80-6999	1320A -1	1 - K 3	FA09-88-104 70	5700A -1	2 - H 5	1243-88-117	5700A -2	2 - I 5	FA07-88-131A71	5700AA-3	2 - E 6	FA07-88-161A01	5700AA-4	2 - F 6
9935-80-6999	4500A -1	1 - G10	FA09-88-104A	5700AA-2	2 - D 6	1243-88-117	5700AA-3	2 - E 6	FA08-88-131	5700A -2	2 - I 5	FA07-88-161A11	5700AA-4	2 - F 6
9935-80-8999	1320A -1	1 - K 3	FA09-88-104A01	5700AA-2	2 - D 6	8183-88-120	5700A -2	2 - I 5	FA08-88-131	5700A -4	2 - K 5	FA07-88-161A71	5700AA-4	2 - F 6
9935-80-8999	4500A -1	1 - G10	FA09-88-104A11	5700AA-2	2 - D 6	8183-88-120	5700AA-3	2 - E 6	FA08-88-131 00	5700A -2	2 - I 5	FA08-88-161	5700A -3	2 - J 5
9935-80-8999	4500A -1	1 - G10	FA09-88-104A71	5700AA-2	2 - D 6	8183-88-120 00	5700A -2	2 - I 5	FA08-88-131 00	5700A -4	2 - K 5	FA08-88-161 00	5700A -3	2 - J 5
0000-81-0093	6680A -2	2 - K 9	8531-88-105	5700A -1	2 - H 5	8183-88-120 00	5700AA-3	2 - E 6	FA08-88-131 70	5700A -4	2 - K 5	FA08-88-161 70	5700A -3	2 - J 5
0000-81-132C	6680A -2	2 - K 9	8531-88-105	5700AA-2	2 - D 6	8183-88-120 10	5700A -2	2 - I 5	FA08-88-131 70	5700A -2	2 - I 5	FA08-88-161A	5700AA-4	2 - F 6
0000-81-142C-83	6680A -2	2 - K 9	8531-88-106	5700A -1	2 - H 5	8183-88-120 10	5700AA-3	2 - E 6	FA08-88-131A	5700AA-3	2 - E 6	FA08-88-161A01	5700AA-4	2 - F 6
0000-81-142C	6680A -2	2 - K 9	8531-88-106	5700AA-2	2 - D 6	8183-88-120 29	5700AA-3	2 - E	FA08-88-131A01	5700AA-3	2 - E 6	FA08-88-161A71	5700AA-4	2 - F 6
0000-81-0211-KB	6680A -1	2 - J 9	8531-88-107	5700A -1	2 - H 5	8183-88-120 70	5700A -2	2 - I 5	FA08-88-131A71	5700AA-3	2 - E 6	FA09-88-161	5700A -3	2 - J 5
0000-81-0211-83	6680A -1	2 - J 9	8531-88-107	5700AA-2	2 - D 6	8183-88-120 70	5700AA-3	2 - E 6	FA09-88-131	5700A -2	2 - I 5	FA09-88-161 00	5700A -3	2 - J 5
0000-81-0286-83	6680A -2	2 - K 9	FA07-88-110	5700A -1	2 - H 5	8871-88-120A	5700A -2	2 - I 5	FA09-88-131 00	5700A -3	2 - J 5	FA09-88-161 10	5700A -3	2 - J 5

PART NUMBER INDEX

PART NUMBER	SECTION	LOCATION	PART NUMBER	SECTION	LOCATION	PART NUMBER	SECTION	LOCATION	PART NUMBER	SECTION	LOCATION
FA09-88-161 70	5700A -3	2 - J 5	FA07-88-181A71	5700AA-5	2 - G 6						
FA09-88-161A	5700AA-4	2 - F 6	FA08-88-181A	5700AA-5	2 - G 6						
FA09-88-161A01	5700AA-4	2 - F 6	FA08-88-181A01	5700AA-5	2 - G 6						
FA09-88-161A11	5700AA-4	2 - F 6	FA08-88-181A71	5700AA-5	2 - G 6						
FA09-88-161A71	5700AA-4	2 - F 6	FA09-88-181	5700A -4	2 - K 5						
8183-88-170	5700A -4	2 - K 5	FA09-88-181 00	5700A -4	2 - K 5						
8183-88-170	5700AA-4	2 - F 6	FA09-88-181 10	5700A -4	2 - K 5						
8183-88-170 00	5700A -4	2 - K 5	FA09-88-181 70	5700A -4	2 - K 5						
8183-88-170 00	5700AA-4	2 - F 6	FA09-88-181A	5700AA-5	2 - G 6						
8183-88-170 10	5700A -4	2 - K 5	FA09-88-181A01	5700AA-5	2 - G 6						
8183-88-170 10	5700AA-4	2 - F 6	FA09-88-181A11	5700AA-5	2 - G 6						
8183-88-170 29	5700AA-4	2 - F 6	FA09-88-181A71	5700AA-5	2 - G 6						
8183-88-170 70	5700A -4	2 - K 5	8871-88-190	5700A -4	2 - K 5						
8183-88-170 70	5700AA-4	2 - F 6	FA02-88-190	5700A -4	2 - K 5						
8871-88-170	5700A -4	2 - K 5	FA09-88-190	5700AA-5	2 - G 6						
FO07-88-170	5700A -3	2 - J 5	8B62-89-334	2610A -1	1 - F 8						
FO07-88-170 00	5700A -3	2 - J 5	FA01-89-376	3700A -1	1 - F 9						
FO07-88-170 10	5700A -4	2 - K 5	FA01-89-376	3700A -2	1 - G 9						
FO07-88-170 70	5700A -4	2 - K 5	1-46-89-376	3700A -1	1 - F 9						
FA02-88-170	5700A -4	2 - K 5	1-82-89-621	6230A -1	2 - K 8						
FA09-88-176	5700AA-4	2 - F 6	8341-89-621	6230A -1	2 - K 8						
FA09-88-176	5700AA-4	2 - F 6	8341-89-621	6230A -1	2 - K 8						
FA09-88-176 01	5700AA-4	2 - F 6	8871-89-661	5100A -1	2 - J 3						
FA09-88-176 11	5700AA-4	2 - F 6	FA02-89-661	5100A -1	2 - J 3						
FA09-88-176 29	5700AA-4	2 - F 6	FA01-89-662	5105A -1	2 - L 3						
FA09-88-176 71	5700AA-4	2 - F 6	FA01-89-663	5105A -1	2 - L 3						
FA07-88-180	5700A -4	2 - K 5	FA01-89-664	5110A -1	2 - M 3						
FA07-88-180 00	5700A -4	2 - K 5	3874-89-665A	5120A -1	2 - N 3						
FA07-88-180 10	5700A -4	2 - K 5	8871-89-666	5100A -1	2 - J 3						
FA07-88-180 70	5700A -4	2 - K 5	FA02-89-666	5100A -1	2 - J 3						
FA07-88-180A	5700AA-5	2 - G 6	FA01-89-667	5105A -1	2 - L 3						
FA07-88-180A01	5700AA-5	2 - G 6	FA01-89-668	5105A -1	2 - L 3						
FA07-88-180A11	5700AA-5	2 - G 6	FA01-89-669	5110A -1	2 - M 3						
FA07-88-180A71	5700AA-5	2 - G 6	FA01-89-673	5120A -1	2 - N 3						
FA08-88-180	5700A -4	2 - K 5	FA01-89-678	5120A -1	2 - N 3						
FA08-88-180 00	5700A -4	2 - K 5	N221-99-041	1320A -1	1 - K 3						
FA08-88-180 70	5700A -4	2 - K 5	FA30-99-063A	6640A -1	2 - I 9						
FA08-88-180A	5700AA-5	2 - G 6	N201-99-100	1000A -1	1 - C 3						
FA08-88-180A01	5700AA-5	2 - G 6	N231-99-100	1000A -1	1 - C 3						
FA08-88-180A71	5700AA-5	2 - G 6	N201-99-131	1359A -1	1 - N 3						
FA09-88-180	5700A -4	2 - K 5	N201-99-131	1359A -1	1 - N 3						
FA09-88-180 00	5700A -4	2 - K 5	8553-99-152	1500A -1	1 - K 4						
FA09-88-180 10	5700A -4	2 - K 5	8553-99-152	1500AA-1	1 - M 4						
FA09-88-180 70	5700A -4	2 - K 5	N232-99-153A	1500A -1	1 - K 4						
FA09-88-180A	5700AA-5	2 - G 6	N232-99-153A	1500AA-1	1 - M 4						
FA09-88-180A01	5700AA-5	2 - G 6	0305-99-178	1720A -1	1 - G 5						
FA09-88-180A11	5700AA-5	2 - G 6	M503-99-178	1720A -1	1 - G 5						
FA09-88-180A71	5700AA-5	2 - G 6	FA01-99-281A	2800A -1	1 - J 8						
FA10-88-180A	5700AA-5	2 - G 6	8531-99-322A	3230A -1	1 - N 8						
FA10-88-180A01	5700AA-5	2 - G 6	8021-99-324	3230A -1	1 - N 8						
FA10-88-180A11	5700AA-5	2 - G 6	8871-99-741B	5030A -1	2 - G 3						
FA10-88-180A71	5700AA-5	2 - G 6	8871-99-742B	5030A -1	2 - G 3						
FA07-88-181A	5700AA-5	2 - G 6	8871-99-743B	5030A -1	2 - G 3						
FA07-88-181A01	5700AA-5	2 - G 6	8871-99-744B	5030A -1	2 - G 3						
FA07-88-181A11	5700AA-5	2 - G 6	8871-99-745A	5030A -1	2 - G 3						